

GLYCOL UNIT COOLERS

Technical Guide
LOP, CM, LVCM, MP

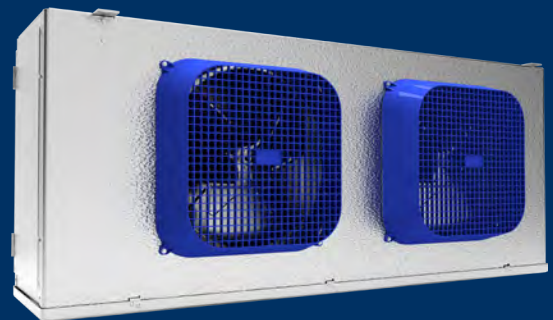
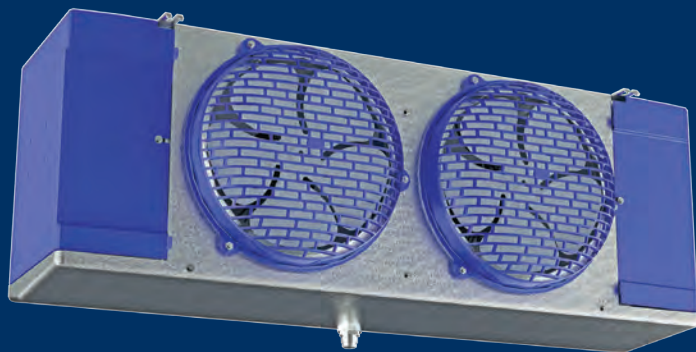
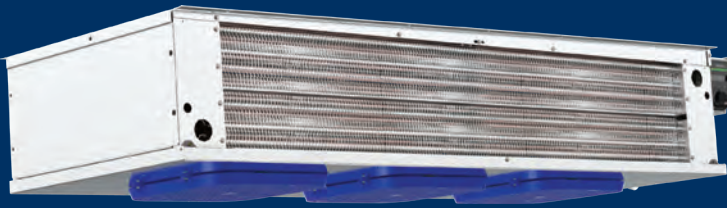

TABLE OF CONTENTS

3	Nomenclature
4	Features & Benefits
5	Low Profile Models
5	Capacity Tables
5	Fixed Speed EC Motors
6	Two Speed EC Motors
7	PSC Motors
8	8 Glycol Unit Cooler Weights & Fluid Capacities
9	9 Glycol Models Physical Data
10	10 Dimensional Data
11	Center Mount Models
11	Capacity Tables
11	EC Motors
12	12 Glycol Unit Cooler Weights & Fluid Capacities
13	13 Glycol Models Physical Data
14	14 Dimensional Data
15	Low Velocity Center Mount
15	Capacity Tables
15	EC Motors
16	16 Glycol Unit Cooler Weights & Fluid Capacities
17	17 Glycol Models Physical Data
18	18 Dimensional Data
19	Medium Profile
19	Capacity Tables
19	PSC Motors
20	1 Speed EC Motors
21	21 Glycol Unit Cooler Weights & Fluid Capacities
22	22 Glycol Models Physical Data
23	23 Dimensional Data
24	Replacement Parts
24	LOP Glycol Unit Coolers
28	CM Glycol Unit Coolers
29	LVCM Glycol Unit Coolers
30	MP Glycol Unit Coolers



Notes:
* NSF not applicable for Medium Profile

NOMENCLATURE

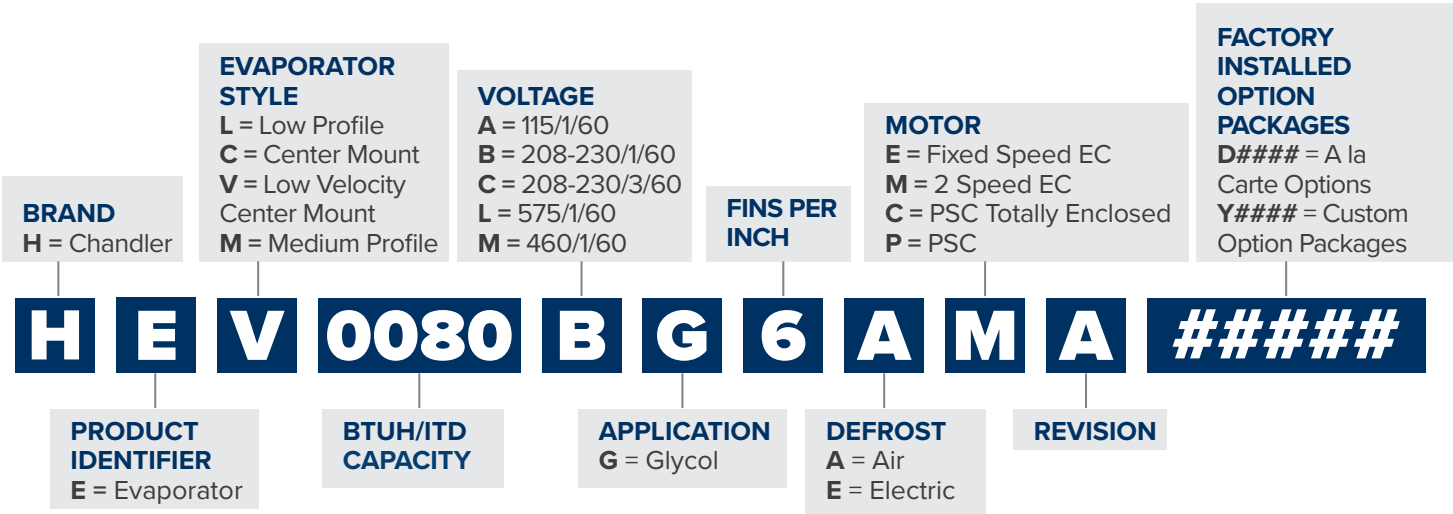

FEATURES & BENEFITS

These units will work with a variety of fluids, Propylene glycol mixtures are most common but not the only ones employed. They're UL-listed for the US and Canada and meet NSF standards.

LOW VELOCITY CENTER MOUNT	LOW PROFILE	MEDIUM PROFILE*	CENTER MOUNT
CABINET			
Low air velocity helps to maintain high humidities and prevent product drying and weight loss; low sound makes a comfortable working environment	Minimal height of the low profile series makes it ideal for low ceiling coolers, allowing for maximum headroom and more product storage	Heavy-duty design is ideal for larger walk-in coolers and freezers	Compact center-ceiling mount design allows for shelving and storage of product around walls.
Textured aluminum cabinet for maximum durability	Textured aluminum cabinet design features front access panels on each side for easy access to electrical and refrigeration components	Textured aluminum cabinet for maximum durability	Textured aluminum cabinet for maximum durability
All electrical components factory wired to terminal board and identified, making it easy to field wire the unit.			
Internal panels are "isolated" which provides for quiet unit operation			
HEATERS AND COIL			
Not supporting warm fluid defrost for LOP, CM & LVCM due to very low volume (ETO only).			
All warm-fluid defrost models have heater/fan control factory set and wired All electric defrost models include defrost termination thermostats			
Coils are dehydrated and sealed at the factory			
Sweat connections to reduce potential for leaks			
Vent and drain fittings for proper charging of system			
GUARDS AND MOTORS			
Wire fan guards with PVC coating provide added durability	Featuring molded guards and a motor mount design that is optimized to minimize vibration	Standard molded fan guards provide excellent air throw (optional wire fan guard for diffused air pattern)	Wire fan guards with PVC coating provide added durability
Motors plug into wiring harness for easier servicing			
DRAIN PAN			
Double drain pan prevents drain pan sweating	Optimized drain fitting position	Front hinged drain pan for easy access	Double drain pan prevents drain pan sweating
OPTIONS			
NA	Energy-efficient PSC motors 115/1/60, 208-230/1/60 (TEAO motors are standard on 115V and special order on 230V and 460V)	PSC motors are standard (TEAO motors are special order on 230V and 460V)	NA
Standard for LVCM	Optional Energy-Efficient EC Motors (115/1/60 or 208-230/1/60)		Standard for CM
575 volt units are not available	575 volt units are not available	575 volt units are not available	575 volt units are not available
Available in stainless steel cabinets and/or drain pan			
Copper fin or coil coating			
Shipped loose shut-off and balance valves			
Factory-mounted balance and shut-off valves are available only with Medium Profile			

Notes:
* Doesn't meet NSF, not available in stainless steel

LOW PROFILE

LOP Models with Fixed Speed EC Motors

Model	Capacity BTUH/°ITD*	Fixed Speed EC Motors									
		Fan Data		Fan Motor Data (Total Amps/Watts)				Defrost Heaters			
		No.	CFM	HP	115/1/60 A, W	208-230/ 1/60 A, W	460/1/60 A, W	Watts	230/1/60	230/3/60	460/1/60
*EL0400^G6AEA	400	2	1,305	1/20	1.8, 110	1.0, 118	-	-	-	-	-
*EL0550^G6AEA	550	2	1,220	1/20	1.8, 110	1.0, 118	-	-	-	-	-
*EL0650^G6AEA	650	2	1,220	1/20	1.8, 110	1.0, 118	-	-	-	-	-
*EL0800^G6AEA	800	3	1,830	1/20	2.7, 165	1.5, 177	-	-	-	-	-
*EL1000^G6AEA	1,000	4	2,440	1/20	3.6, 220	2.0, 236	-	-	-	-	-
*EL1150^G6AEA	1,150	5	2,660	1/20	4.5, 275	2.5, 295	-	-	-	-	-
*EL1350^G6AEA	1,350	5	2,500	1/20	4.5, 275	2.5, 295	-	-	-	-	-
*EL1500^G6AEA	1,500	6	3,000	1/20	5.4, 330	3.0, 354	-	-	-	-	-
*EL0400^G6EEA	400	2	1,305	1/20	-	-	-	2,100	9.1	5.7	4.6
*EL0550^G6EEA	550	2	1,220	1/20	-	-	-	2,100	9.1	5.7	4.6
*EL0650^G6EEA	650	2	1,220	1/20	-	-	-	2,100	9.1	5.7	4.6
*EL0800^G6EEA	800	3	1,830	1/20	-	-	-	3,150	13.7	8.5	6.8
*EL1000^G6EEA	1,000	4	2,440	1/20	-	-	-	4,200	18.3	11.4	-
*EL1150^G6EEA	1,150	5	2,660	1/20	-	-	-	5,250	22.8	14.2	11.4
*EL1350^G6EEA	1,350	5	2,500	1/20	-	-	-	5,250	22.8	14.2	11.4
*EL1500^G6EEA	1,500	6	3,000	1/20	-	-	-	6,300	27.4	17.1	13.7

Notes:

^ Electrical code (A = 115/1/60, B = 208-230/1/60, M = 460/1/60)

Initial temperature difference (ITD) is (Room air temperature - Entering fluid temperature)

Multiply the reference capacity by the ITD to get the reference capacity

LOW PROFILE

LOP Models with Two Speed EC Motors

		Two Speed EC Motors									
		Fan Data		Fan Motor Data (Total Amps/Watts)				Defrost Heaters			
Model	Capacity BTUH/°ITD*	No.	CFM	HP	115/1/60 A, W	208-230/ 1/60 A, W	460/1/60 A, W	Watts	230/1/60	230/1360	460/1/60
*EL0400^G6AMA	400	2	1,305	1/20	1.8, 110	1.0, 110	-	-	-	-	-
*EL0550^G6AMA	550	2	1,220	1/20	1.8, 110	1.0, 110	-	-	-	-	-
*EL0650^G6AMA	650	2	1,220	1/20	1.8, 110	1.0, 110	-	-	-	-	-
*EL0800^G6AMA	800	3	1,830	1/20	2.7, 165	1.5, 165	-	-	-	-	-
*EL1000^G6AMA	1,000	4	2,440	1/20	3.6, 220	2.0, 220	-	-	-	-	-
*EL1150^G6AMA	1,150	5	2,660	1/20	4.5, 275	2.5, 275	-	-	-	-	-
*EL1350^G6AMA	1,350	5	2,500	1/20	4.5, 275	2.5, 275	-	-	-	-	-
*EL1500^G6AMA	1,500	6	3,000	1/20	5.4, 330	3.0, 330	-	-	-	-	-
*EL0400^G6EMA	400	2	1,305	1/20	-	1.0, 110	-	2,100	9.1	5.7	4.6
*EL0550^G6EMA	550	2	1,220	1/20	-	1.0, 110	-	2,100	9.1	5.7	4.6
*EL0650^G6EMA	650	2	1,220	1/20	-	1.0, 110	-	2,100	9.1	5.7	4.6
*EL0800^G6EMA	800	3	1,830	1/20	-	1.5, 165	-	3,150	13.7	8.5	6.8
*EL1000^G6EMA	1,000	4	2,440	1/20	-	2.0, 220	-	4,200	18.3	11.4	-
*EL1150^G6EMA	1,150	5	2,660	1/20	-	2.5, 275	-	5,250	22.8	14.2	11.4
*EL1350^G6EMA	1,350	5	2,500	1/20	-	2.5, 275	-	5,250	22.8	14.2	11.4
*EL1500^G6EMA	1,500	6	3,000	1/20	-	3.0, 330	-	6,300	27.4	17.1	13.7

Notes:

^ Electrical code (A = 115/1/60, B = 208-230/1/60, M = 460/1/60)

Initial temperature difference (ITD) is (Room air temperature - Entering fluid temperature)

Multiply the reference capacity by the ITD to get the reference capacity

LOW PROFILE

LOP Models with PSC Motors

Model	Capacity BTUH/°ITD*	PSC Motors										
		Fan Data		Fan Motor Data (Total Amps/Watts)					Defrost Heaters			
		No.	CFM	HP	115/1/60 A, W	208-230/ 1/60 A, W	460/1/60 A, W	Watts	230/1/60	230/3/60	460/1/60	
*EL0400^G6ACA	400	2	1,305	1/20	2.0, 164	1.0, 182	0.8, 234	-	-	-	-	
*EL0550^G6ACA	550	2	1,220	1/20	2.0, 164	1.0, 182	0.8, 234	-	-	-	-	
*EL0650^G6ACA	650	2	1,220	1/20	2.0, 164	1.0, 182	0.8, 234	-	-	-	-	
*EL0800^G6ACA	800	3	1,830	1/20	3.0, 246	1.5, 273	1.2, 351	-	-	-	-	
*EL1000^G6ACA	1,000	4	2,440	1/20	4.0, 328	2.0, 364	1.6, 468	-	-	-	-	
*EL1150^G6ACA	1,150	5	2,660	1/20	5.0, 410	2.5, 455	2.0, 585	-	-	-	-	
*EL1350^G6ACA	1,350	5	2,500	1/20	5.0, 410	2.5, 455	2.0, 585	-	-	-	-	
*EL1500^G6ACA	1,500	6	3,000	1/20	6.0, 492	3.0, 546	2.4, 702	-	-	-	-	
*EL0400^G6ECA	400	2	1,305	1/20	2.0, 164	1.0, 182	0.8, 234	2,100	9.1	5.7	4.6	
*EL0550^G6ECA	550	2	1,220	1/20	2.0, 164	1.0, 182	0.8, 234	2,100	9.1	5.7	4.6	
*EL0650^G6ECA	650	2	1,220	1/20	2.0, 164	1.0, 182	0.8, 234	2,100	9.1	5.7	4.6	
*EL0800^G6ECA	800	3	1,830	1/20	3.0, 246	1.5, 273	1.2, 351	3,150	13.7	8.5	6.8	
*EL1000^G6ECA	1,000	4	2,440	1/20	4.0, 328	2.0, 364	1.6, 468	4,200	18.3	11.4	-	
*EL1150^G6ECA	1,150	5	2,660	1/20	5.0, 410	2.5, 455	2.0, 585	5,250	22.8	14.2	11.4	
*EL1350^G6ECA	1,350	5	2,500	1/20	5.0, 410	2.5, 455	2.0, 585	5,250	22.8	14.2	11.4	
*EL1500^G6ECA	1,500	6	3,000	1/20	6.0, 492	3.0, 546	2.4, 702	6,300	27.4	17.1	13.7	

Notes:

^ Electrical code (A = 115/1/60, B = 208-230/1/60, M = 460/1/60)

Initial temperature difference (ITD) is (Room air temperature - Entering fluid temperature)

Multiply the reference capacity by the ITD to get the reference capacity

LOW PROFILE

Glycol Unit Cooler Weights & Fluid Capacities

Product Family	Defrost	Model Size	# Coil Circuits	Coil Header CONN OD In.	Unit Internal Volume ft ³ /m ³	Air Defrost Net Wt. (empty) lbs/kg	Unit Internal Fluid Capacity	
							lbs/kg*	gal/l
LOP	AIR	400	4	7/8	0.10/0.003	52/24	7/3	0.7/2.8
LOP	AIR	550	6	7/8	0.13/0.004	56/26	9/4	1.0/3.8
LOP	AIR	650	8	1 1/8	0.13/0.004	56/26	9/4	1.0/3.8
LOP	AIR	800	8	1 1/8	0.18/0.005	73/33	12/5	1.3/5.1
LOP	AIR	1000	12	1 1/8	0.25/0.007	94/43	16/7	1.9/7.1
LOP	AIR	1150	12	1 1/8	0.30/0.008	115/52	19/9	2.2/8.4
LOP	AIR	1350	8	1 1/8	0.51/0.014	128/58	33/15	3.8/14.4
LOP	AIR	1500	8	1 1/8	0.59/0.017	152/69	38/17	4.4/16.8
LOP	ELECTRIC	400	4	7/8	0.10/0.003	55/25	7/3	0.7/2.8
LOP	ELECTRIC	550	6	7/8	0.13/0.004	59/27	9/4	1.0/3.8
LOP	ELECTRIC	650	8	1 1/8	0.13/0.004	59/27	9/4	1.0/3.8
LOP	ELECTRIC	800	8	1 1/8	0.18/0.005	77/35	12/5	1.3/5.1
LOP	ELECTRIC	1000	12	1 1/8	0.25/0.007	99/45	16/7	1.9/7.1
LOP	ELECTRIC	1150	12	1 1/8	0.30/0.008	121/55	19/9	2.2/8.4
LOP	ELECTRIC	1350	8	1 1/8	0.51/0.014	134/61	33/15	3.8/14.4
LOP	ELECTRIC	1500	8	1 1/8	0.59/0.017	159/72	38/17	4.4/16.8

Notes:

*Based on 35% (by volume) Propylene Glycol

LOW PROFILE

Glycol Models Physical Data

Model	No. of Fans	Coil Data					Condensate Drain	Defrost Type	Approx. Net Wt. Lbs.	Approx. Gross Wt. Lbs.
		FPI	Tube OD	# of Circuits	Connections OD	Finned Length				
HEL0400*G6A^A	2	6	3/8	4	7/8	32	3/4 MPT	AIR	52	24
HEL0550*G6A^A	2	6	3/8	6	7/8	32	3/4 MPT	AIR	56	26
HEL0650*G6A^A	2	6	3/8	8	1-1/8	32	3/4 MPT	AIR	56	26
HEL0800*G6A^A	3	6	3/8	8	1-1/8	48	3/4 MPT	AIR	73	33
HEL1000*G6A^A	4	6	3/8	12	1-1/8	64	3/4 MPT	AIR	94	43
HEL1150*G6A^A	5	6	3/8	12	1-1/8	80	3/4 MPT	AIR	115	52
HEL1350*G6A^A	5	6	1/2	8	1-1/8	80	3/4 MPT	AIR	128	58
HEL1500*G6A^A	6	6	1/2	8	1-1/8	96	3/4 MPT	AIR	152	69
HEL0400*G6E^A	2	6	3/8	4	7/8	32	3/4 MPT	ELECTRIC	55	25
HEL0550*G6E^A	2	6	3/8	6	7/8	32	3/4 MPT	ELECTRIC	59	27
HEL0650*G6E^A	2	6	3/8	8	1-1/8	32	3/4 MPT	ELECTRIC	59	27
HEL0800*G6E^A	3	6	3/8	8	1-1/8	48	3/4 MPT	ELECTRIC	77	35
HEL1000*G6E^A	4	6	3/8	12	1-1/8	64	3/4 MPT	ELECTRIC	99	45
HEL1150*G6E^A	5	6	3/8	12	1-1/8	80	3/4 MPT	ELECTRIC	121	55
HEL1350*G6E^A	5	6	1/2	8	1-1/8	80	3/4 MPT	ELECTRIC	134	61
HEL1500*G6E^A	6	6	1/2	8	1-1/8	96	3/4 MPT	ELECTRIC	159	72

Notes:

^ Electrical code (A = 115/1/60, B = 208-230/1/60, M = 460/1/60)

LOW PROFILE

Dimensional Data

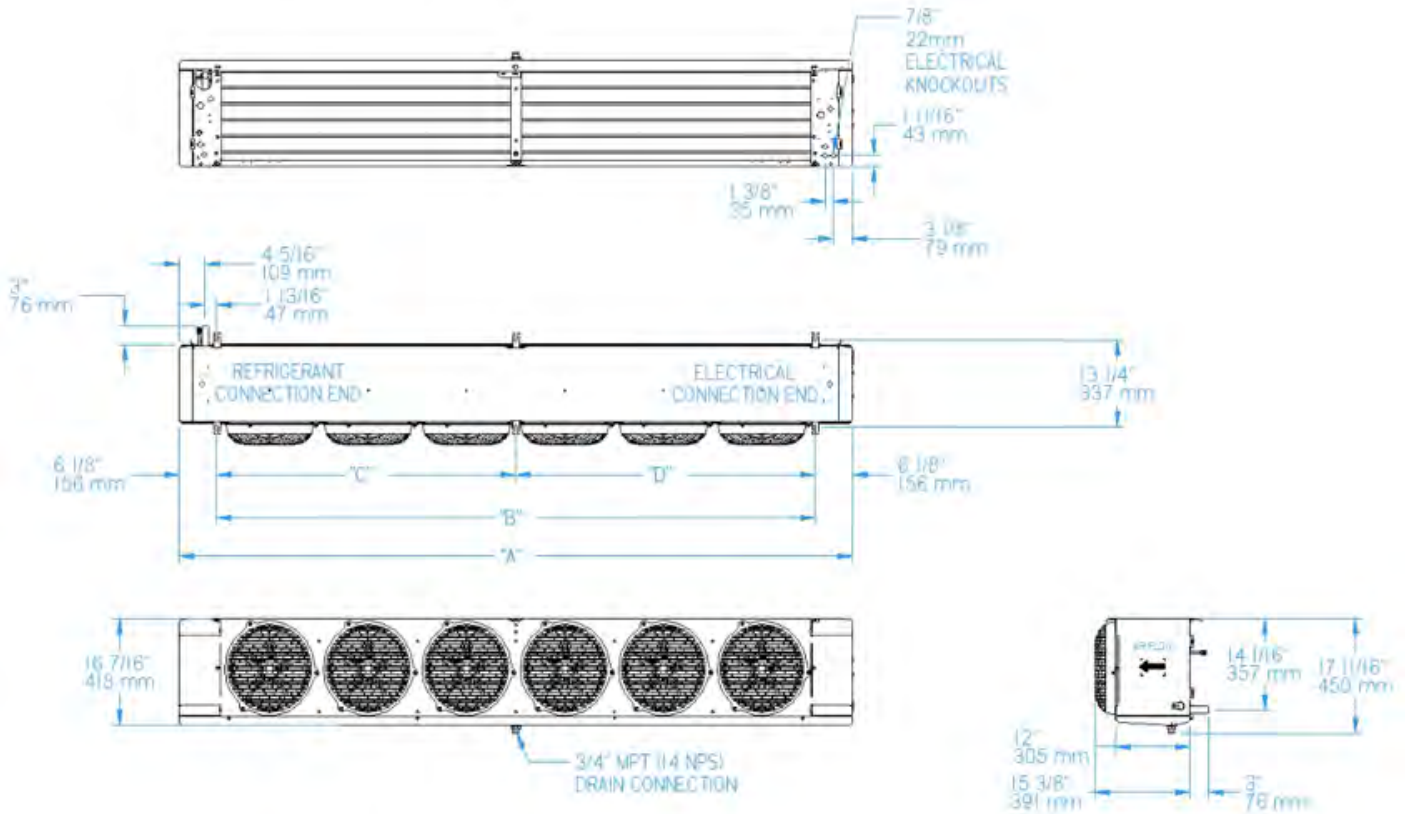

No. of Fans	A		B		C		D	
	in.	mm	in.	mm	in.	mm	in.	mm
1	29.5	749.3	17.25	438.1	-	-	-	-
2	45.5	1,155.70	33.25	845	-	-	-	-
3	61.5	1,562.10	49.25	1,251	-	-	-	-
4	77.5	1,968.50	65.25	1,657	-	-	-	-
5	93.5	2,374.90	81.25	2,064	48.63	1,235.10	32.63	828.7
6	109.5	2,781.30	97.25	2,470	48.63	1,235.10	48.63	1,235.10

Notes:
Hanger brackets will accept 3/8" / 9.5 mm hanger rods

CENTER MOUNT

CM Models with EC Motors

Model	Capacity BTUH/°ITD [#]	EC Motors				
		Fan Data		Fan Motor Data (Total Amps/Watts)		
		No.	CFM	HP	115/1/60 A, W	208-230/ 1/60 A, W
*EC0450^G7AEA	450	2	1,260	1/20	1.68, 74	0.84, 74
*EC0550^G7AEA	550	2	1,260	1/20	1.68, 74	0.84, 74
*EC0600^G7AEA	600	2	1,260	1/20	1.68, 74	0.84, 74
*EC0700^G7AEA	700	2	1,260	1/20	1.68, 74	0.84, 74
*EC0750^G7AEA	750	3	1,890	1/20	2.52, 111	1.26, 111
*EC0850^G7AEA	850	3	1,890	1/20	2.52, 111	1.26, 111
*EC0950^G7AEA	950	4	2,520	1/20	3.36, 148	1.68, 148
*EC1150^G7AEA	1,150	4	2,440	1/20	3.36, 148	1.68, 148

Notes:

* Glycol available in all Brands (Bohn, Larkin, Climate Control & Chandler)

^ Electrical code (A = 115/1/60, B = 208-230/1/60)

Initial temperature difference (ITD) is (Room air temperature - Entering fluid temperature)

Multiply the reference capacity by the ITD to get the reference capacity

CENTER MOUNT

Glycol Unit Cooler Weights & Fluid Capacities

Product Family	Air Defrost Model Guide	Warm Fluid Defrost Model	# Coil Circuits	Coil Header CONN OD In.	Unit Internal Volume ft ³ /m ³	Air Defrost Net Wt. (empty) lbs/kg	Electric & W.F. Defrost Net Wt. (empty) ft ³ /m ³ *	Unit Internal Fluid Capacity	
								lbs/kg*	gal/l
CM	0450	---	4	7/8	0.09 / 0.003	70 / 32	---	7 / 3	0.9 / 3.4
CM	0550	---	6	7/8	0.10 / 0.003	77 / 35	---	7 / 3	1.0 / 3.8
CM	0600	---	6	7/8	0.14 / 0.004	100 / 45	---	9 / 4	1.3 / 4.9
CM	0700	---	8	7/8	0.14 / 0.004	100 / 45	---	9 / 4	1.3 / 4.9
CM	0750	---	8	7/8	0.13 / 0.004	126 / 57	---	9 / 4	1.2 / 4.5
CM	0850	---	8	7/8	0.20 / 0.006	141 / 64	---	13 / 6	1.7 / 6.4
CM	0950	---	8	1 - 1/8	0.26 / 0.007	179 / 81	---	15 / 7	2.4 / 9.1
CM	1150	---	10	1 - 1/8	0.33 / 0.009	197 / 89	---	20 / 9	2.9 / 11

Notes:

* Based on 35% (by volume) Propylene Glycol

CENTER MOUNT

Glycol Models Physical Data

Model	No. of Fans	Coil Data					Condensate Drain	Defrost Type	Approx. Net Wt. Lbs.
		FPI	Tube OD	# of Circuits	Connections OD	Finned Length			
*EC0450^G7AEA	2	7	3/8	4	7/8	44	3/4 FPT	Air	70
*EC0550^G7AEA	2	7	3/8	6	7/8	44	3/4 FPT	Air	77
*EC0600^G7AEA	2	7	3/8	6	7/8	44	3/4 FPT	Air	100
*EC0700^G7AEA	2	7	3/8	8	7/8	44	3/4 FPT	Air	100
*EC0750^G7AEA	3	7	3/8	8	7/8	66	3/4 FPT	Air	126
*EC0850^G7AEA	3	7	3/8	8	7/8	66	3/4 FPT	Air	141
*EC0950^G7AEA	4	7	3/8	8	1 - 1/8	88	3/4 FPT	Air	179
*EC1150^G7AEA	4	7	3/8	10	1 - 1/8	88	3/4 FPT	Air	197

Notes:

* Glycol available in all Brands (Bohn, Larkin, Climate Control & Chandler)

^ Electrical code (A = 115/1/60 or B = 208-230/1/60)

CENTER MOUNT

Dimensional Data

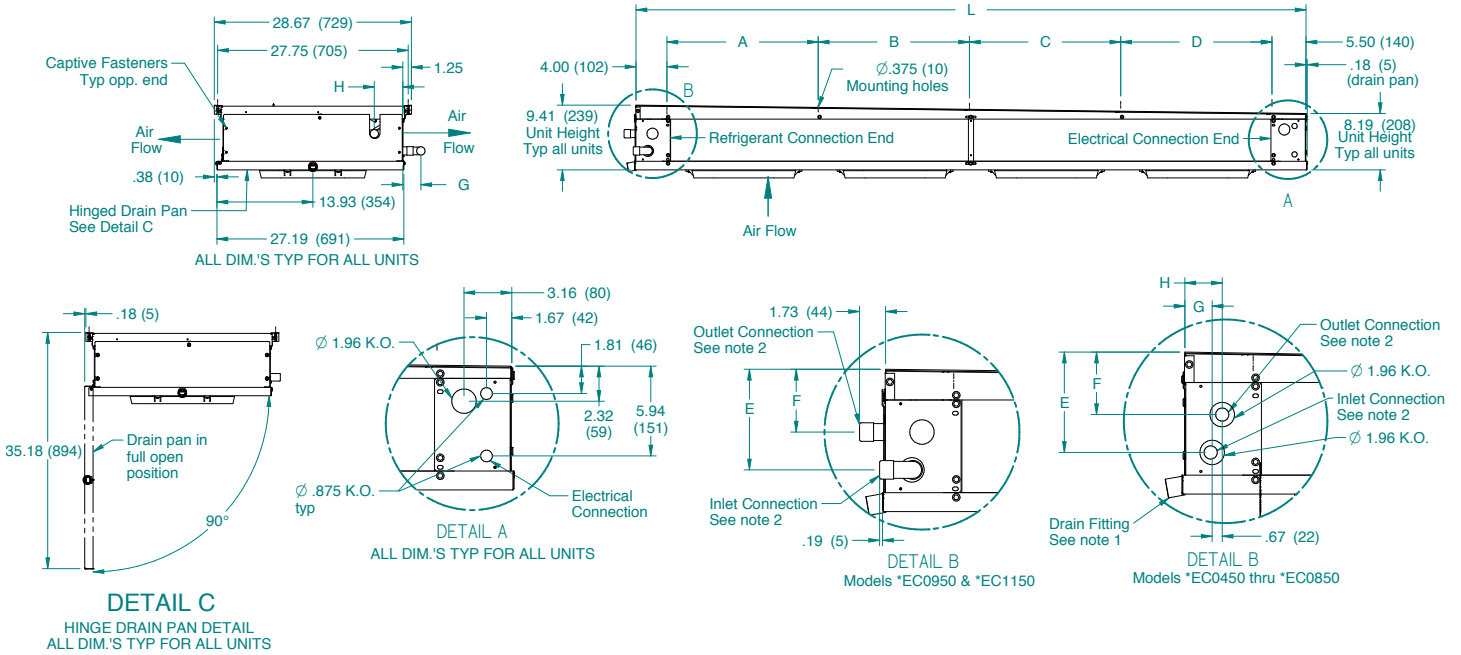

Model	No. of Fans	Defrost Type	Dimensions (Inches, mm)								
			A	B	C	D	E	F	G	H	L
*EC0450^G7AEA	2	Air	22 (559)	22 (559)	-	-	6 5/8 (168)	4 1/8 (105)	13/4 (45)	2 1/2 (63)	53 1/2 (1359)
*EC0550^G7AEA	2	Air	22 (559)	22 (559)	-	-	6 5/8 (168)	4 1/8 (105)	13/4 (45)	2 1/2 (63)	53 1/2 (1359)
*EC0600^G7AEA	2	Air	22 (559)	22 (559)	-	-	6 5/8 (168)	4 1/8 (105)	13/4 (45)	2 1/2 (63)	53 1/2 (1359)
*EC0700^G7AEA	2	Air	22 (559)	22 (559)	-	-	6 5/8 (168)	4 1/8 (105)	13/4 (45)	2 1/2 (63)	53 1/2 (1359)
*EC0750^G7AEA	3	Air	22 (559)	22 (559)	22 (559)	-	6 5/8 (168)	4 1/8 (105)	13/4 (45)	2 1/2 (63)	75 1/2 (1918)
*EC0850^G7AEA	3	Air	22 (559)	22 (559)	22 (559)	-	6 5/8 (168)	4 1/8 (105)	13/4 (45)	2 1/2 (63)	75 1/2 (1918)
*EC0950^G7AEA	4	Air	22 (559)	22 (559)	22 (559)	22 (559)	6 5/8 (168)	4 1/8 (105)	2 5/8 (67)	4 1/8 (105)	97 1/2 (2477)
*EC1150^G7AEA	4	Air	22 (559)	22 (559)	22 (559)	22 (559)	6 5/8 (168)	4 1/8 (105)	2 5/8 (67)	4 1/8 (105)	97 1/2 (2477)

Notes:
 ^ Electrical code (A = 115/1/60 or B = 208-230/1/60)
 * Glycol available in all Brands (Bohn, Larkin, Climate Control & Chandler)

LOW VELOCITY CENTER MOUNT

LVCM Models with EC Motors

		Air Defrost							
		Fan Data		Fan Motor Data (Total Amps/Watts)			Defrost Heaters		
Model	Capacity BTUH/°ITD [#]	No.	CFM	HP	115/1/60 A, W	208-230/1/60 A, W	Watts	115/1/60 A, W	208-230/1/60 A, W
*EV0400^G6AEA	400	1	730	1/20	0.84 , 37	0.42 , 37	-	-	-
*EV0500^G6AEA	500	1	725	1/20	0.84 , 37	0.42 , 37	-	-	-
*EV0750^G6AEA	750	2	1,450	1/20	1.68 , 74	0.84 , 74	-	-	-
*EV0950^G6AEA	950	2	1,430	1/20	1.68 , 74	0.84 , 74	-	-	-
*EV1100^G6AEA	1,100	3	2,100	1/20	2.52 , 111	1.26 , 111	-	-	-
*EV1400^G6AEA	1,400	3	2,100	1/20	2.52 , 111	1.26 , 111	-	-	-
*EV1650^G6AEA	1,650	4	2,800	1/20	3.36 , 148	1.68 , 148	-	-	-

		Electric Defrost							
		Fan Data		Fan Motor Data (Total Amps/Watts)			Defrost Heaters		
Model	Capacity BTUH/°ITD [#]	No.	CFM	HP	115/1/60 A, W	208-230/1/60 A, W	Watts	115/1/60 A, W	208-230/1/60 A, W
*EV0400BG6EEA	400	1	730	1/20	-	0.42 , 37	1,600	-	7
*EV0500BG6EEA	500	1	725	1/20	-	0.42 , 37	1,600	-	7
*EV0750BG6EEA	750	2	1,450	1/20	-	0.84 , 74	2,800	-	12
*EV0950BG6EEA	950	2	1,430	1/20	-	0.84 , 74	2,800	-	12
*EV1100BG6EEA	1,100	3	2,100	1/20	-	1.26 , 111	4,000	-	17
*EV1400BG6EEA	1,400	3	2,100	1/20	-	1.26 , 111	4,000	-	17
*EV1650BG6EEA	1,650	4	2,800	1/20	-	1.68 , 148	5,200	-	23

Notes:

^ Electrical code (A = 115/1/60 or B = 208-230/1/60)

* Glycol available in all Brands (Bohn, Larkin, Climate Control & Chandler)

Initial temperature difference (ITD) is (Room air temperature - Entering fluid temperature)

Multiply the reference capacity by the ITD to get the reference capacity

LOW VELOCITY CENTER MOUNT

Glycol Unit Cooler Weights & Fluid Capacities

Product Family	Air Defrost Model Guide	# Coil Circuits	Coil Header CONN OD In.	Unit Internal Volume ft ³ /m ³	Air Defrost Net Wt. (empty) lbs/kg	Electric & Defrost Net Wt. (empty) ft ³ /m ³	Unit Internal Fluid Capacity	
							lbs/kg*	gal/l
LVCM	0400	6	7/8	0.09 / 0.002	72 / 33	80 / 36	4 / 2	0.9 / 3.4
LVCM	0500	6	7/8	0.11 / 0.003	84 / 38	90 / 41	7 / 3	1 / 3.8
LVCM	0750	10	7/8	0.17 / 0.005	117 / 53	124 / 56	11 / 5	1.5 / 5.7
LVCM	0950	12	1 - 1/8	0.20 / 0.006	164 / 74	180 / 82	13 / 6	1.8 / 6.8
LVCM	1100	12	1 - 1/8	0.30 / 0.008	179 / 81	185 / 84	18 / 8	2.5 / 9.5
LVCM	1400	20	1 - 1/8	0.33 / 0.009	192 / 87	209 / 95	20 / 9	2.7 / 10.2
LVCM	1650	20	1 - 1/8	0.44 / 0.012	232 / 105	244 / 111	26 / 12	3.7 / 14

Notes:

* Based on 35% (by volume) Propylene Glycol

LOW VELOCITY CENTER MOUNT

Glycol Models Physical Data

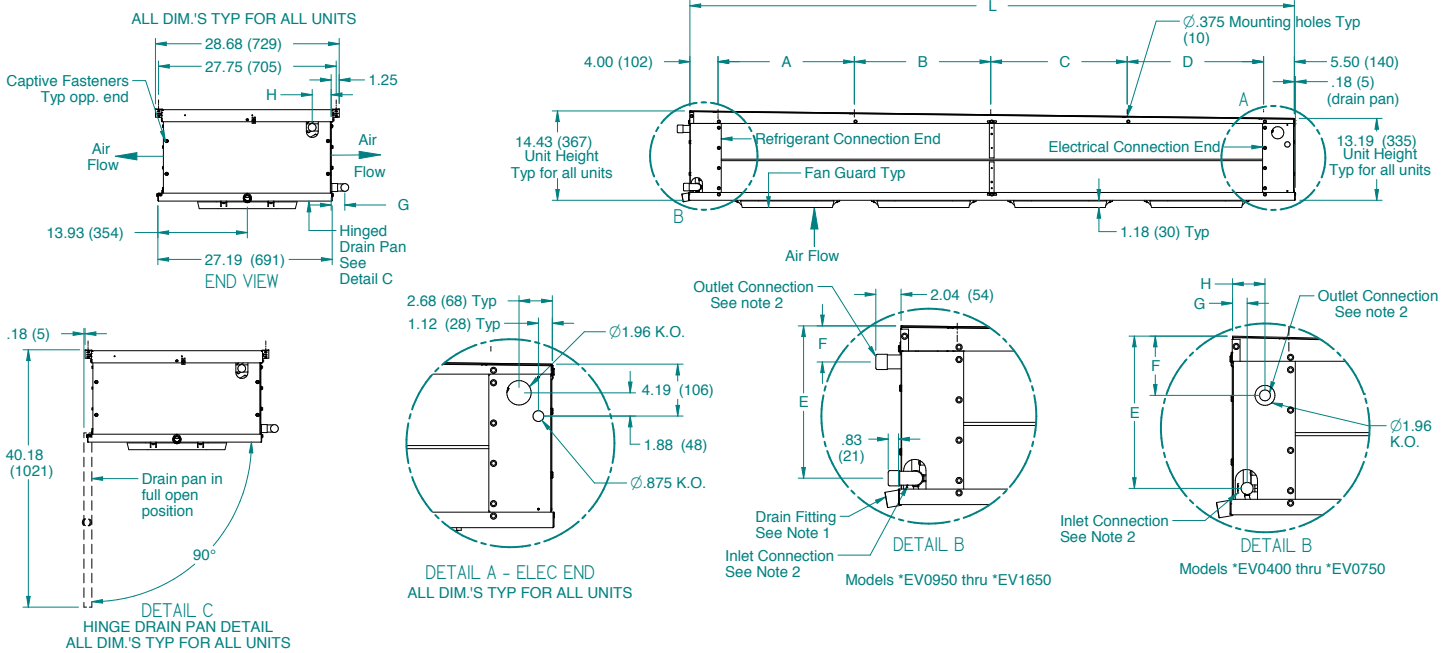

Model	No. of Fans	Coil Data					Condensate Drain	Defrost Type	Approx. Net Wt. Lbs.
		FPI	Tube OD	# of Circuits	Connections OD	Finned Length			
*EV0400^G6AEA	1	6	3/8	6	7/8	22	3/4 FPT	Air	72
*EV0500^G6AEA	1	6	3/8	6	7/8	22	3/4 FPT	Air	84
*EV0750^G6AEA	2	6	3/8	10	7/8	44	3/4 FPT	Air	117
*EV0950^G6AEA	2	6	3/8	12	1 - 1/8	44	3/4 FPT	Air	164
*EV1100^G6AEA	3	6	3/8	12	1 - 1/8	66	3/4 FPT	Air	179
*EV1400^G6AEA	3	6	3/8	20	1 - 1/8	66	3/4 FPT	Air	192
*EV1650^G6AEA	4	6	3/8	20	1 - 1/8	88	3/4 FPT	Air	232
*EV0400^G6EEA	1	6	3/8	6	7/8	22	3/4 FPT	Electric	80
*EV0500^G6EEA	1	6	3/8	6	7/8	22	3/4 FPT	Electric	90
*EV0750^G6EEA	2	6	3/8	10	7/8	44	3/4 FPT	Electric	124
*EV0950^G6EEA	2	6	3/8	12	1 - 1/8	44	3/4 FPT	Electric	180
*EV1100^G6EEA	3	6	3/8	12	1 - 1/8	66	3/4 FPT	Electric	185
*EV1400^G6EEA	3	6	3/8	20	1 - 1/8	66	3/4 FPT	Electric	209
*EV1650^G6EEA	4	6	3/8	20	1 - 1/8	88	3/4 FPT	Electric	244

Notes:

^ Electrical code (A = 115/1/60, B = 208-230/1/60)

* Glycol available in all Brands (Bohn, Larkin, Climate Control & Chandler)

LOW VELOCITY CENTER MOUNT

Dimensional Data

Model	No. of Fans	Defrost Type	Dimensions (Inches, mm)								
			A	B	C	D	E	F	G	H	L
*EV0400^G6AEA	1	Air	22 (559)	-	-	-	12 1/4 (311)	4 3/4 (121)	1 1/4 (32)	2 5/8 (67)	31 1/2 (800)
*EV0500^G6AEA	1	Air	22 (559)	-	-	-	12 1/4 (311)	4 3/4 (121)	1 1/4 (32)	2 5/8 (67)	31 1/2 (800)
*EV0750^G6AEA	2	Air	22 (559)	22 (559)	-	-	12 1/4 (311)	4 3/4 (121)	1 1/4 (32)	2 5/8 (67)	53 1/2 (1359)
*EV0950^G6AEA	2	Air	22 (559)	22 (559)	-	-	12 1/4 (311)	3 (76)	2 1/8 (54)	3 (76)	53 1/2 (1359)
*EV1100^G6AEA	3	Air	22 (559)	22 (559)	22 (559)	-	12 1/4 (311)	3 (76)	2 1/8 (54)	3 (76)	75 1/2 (1918)
*EV1400^G6AEA	3	Air	22 (559)	22 (559)	22 (559)	-	12 1/4 (311)	3 (76)	2 1/8 (54)	3 (76)	75 1/2 (1918)
*EV1650^G6AEA	4	Air	22 (559)	22 (559)	22 (559)	22 (559)	12 1/4 (311)	3 (76)	2 1/8 (54)	3 (76)	97 1/2 (2477)
*EV0400BG6EEA	1	Electric	22 (559)	-	-	-	12 1/4 (311)	4 3/4 (121)	1 1/4 (32)	2 5/8 (67)	31 1/2 (800)
*EV0500BG6EEA	1	Electric	22 (559)	-	-	-	12 1/4 (311)	4 3/4 (121)	1 1/4 (32)	2 5/8 (67)	31 1/2 (800)
*EV0750BG6EEA	2	Electric	22 (559)	22 (559)	-	-	12 1/4 (311)	4 3/4 (121)	1 1/4 (32)	2 5/8 (67)	53 1/2 (1359)
*EV0950BG6EEA	2	Electric	22 (559)	22 (559)	-	-	12 1/4 (311)	3 (76)	2 1/8 (54)	3 (76)	53 1/2 (1359)
*EV1100BG6EEA	3	Electric	22 (559)	22 (559)	22 (559)	-	12 1/4 (311)	3 (76)	2 1/8 (54)	3 (76)	75 1/2 (1918)
*EV1400BG6EEA	3	Electric	22 (559)	22 (559)	22 (559)	-	12 1/4 (311)	3 (76)	2 1/8 (54)	3 (76)	75 1/2 (1918)
*EV1650BG6EEA	4	Electric	22 (559)	22 (559)	22 (559)	22 (559)	12 1/4 (311)	3 (76)	2 1/8 (54)	3 (76)	97 1/2 (2477)

Notes:

^ Electrical code (A = 115/1/60, B = 208-230/1/60)

* Glycol available in all Brands (Bohn, Larkin, Climate Control & Chandler)

MEDIUM PROFILE

MP Models with PSC Motors

Model	Capacity BTUH/°ITD*	PSC Motors						
		Fan Data		Fan Motor Data (Total Amps/Watts)				
		No.	CFM	HP	115/1/60 A, W	208-230/ 1/60 A, W	460/1/60 A, W	575/1/60 A, W
*EM0900^G6ACA	900	1	2,150	1/4	4.0, 300	1.8, 305	1.0, 305	0.8, 310
*EM1100^G6ACA	1,100	2	4,550	1/4	8.0, 600	3.6, 610	2.0, 610	1.5, 620
*EM1275^G6ACA	1,275	2	4,350	1/4	8.0, 600	3.6, 610	2.0, 610	1.5, 620
*EM1450^G6ACA	1,450	2	4,350	1/4	8.0, 600	3.6, 610	2.0, 610	1.5, 620
*EM1600^G6ACA	1,600	2	4,350	1/4	8.0, 600	3.6, 610	2.0, 610	1.5, 620
*EM1700^G6ACA	1,700	3	6,800	1/4	12.0, 900	5.4, 915	3.0, 915	2.3, 930
*EM1900^G6ACA	1,900	3	6,500	1/4	12.0, 900	5.4, 915	3.0, 915	2.3, 930
*EM2175^G6ACA	2,175	3	6,500	1/4	12.0, 900	5.4, 915	3.0, 915	2.3, 930
*EM2400^G6ACA	2,400	4	8,500	1/4	16.0, 1200	7.2, 1220	4.0, 1220	3.0, 1240
*EM2850^G6ACA	2,850	4	8,100	1/4	16.0, 1200	7.2, 1220	4.0, 1220	3.0, 1240
*EM3100^G6ACA	3,100	5	9,650	1/4	-	9, 1525	5.0, 1525	3.8, 1550

Notes:

^ Electrical code (A = 115/1/60, B = 208-230/1/60, M = 460/1/60)

Initial temperature difference (ITD) is (Room air temperature - Entering fluid temperature)

Multiply the reference capacity by the ITD to get the reference capacity

MEDIUM PROFILE

MP Models with 1 Speed EC Motors

Model	Capacity BTUH/°ITD*	1 Speed EC Motors				
		Fan Data		Fan Motor Data (Total Amps/Watts)		
		No.	CFM	HP	115/1/60 A, W	208-230/ 1/60 A, W
*EM0900^G6AEA	900	1	2,150	1/4	3.5, 208	1.7, 208
*EM1100^G6AEA	1,100	2	4,550	1/4	7.0, 417	3.5, 417
*EM1275^G6AEA	1,275	2	4,350	1/4	7.0, 417	3.5, 417
*EM1450^G6AEA	1,450	2	4,350	1/4	7.0, 417	3.5, 417
*EM1600^G6AEA	1,600	2	4,350	1/4	7.0, 417	3.5, 417
*EM1700^G6AEA	1,700	3	6,800	1/4	10.4, 625	5.2, 625
*EM1900^G6AEA	1,900	3	6,500	1/4	10.4, 625	5.2, 625
*EM2175^G6AEA	2,175	3	6,500	1/4	10.4, 625	5.2, 625
*EM2400^G6AEA	2,400	4	8,500	1/4	13.9, 834	7.0, 834
*EM2850^G6AEA	2,850	4	8,100	1/4	13.9, 834	7.0, 834
*EM3100^G6AEA	3,100	5	9,650	1/4	-	8.7, 1042

Notes:

^ Electrical code (A = 115/1/60, B = 208-230/1/60, M = 460/1/60, L = 575/1/60)

Initial temperature difference (ITD) is (Room air temperature - Entering fluid temperature)

Multiply the reference capacity by the ITD to get the reference capacity

MEDIUM PROFILE

Glycol Unit Cooler Weights & Fluid Capacities

Product Family	Air Defrost Model Size	# Coil Circuits	Coil Header Conn OD In.	Unit Internal Volume ft ³ /m ³	Air Defrost Net Wt. (empty) lbs/kg	Unit Internal Fluid Capacity	
						lbs/kg*	gal/l
MP	900	11	7/8	0.20/0.006	160/73	14/6	1.6/6.0
MP	1,100	11	7/8	0.27/0.008	180/82	18/8	2.1/8.0
MP	1,275	11	7/8	0.35/0.010	200/91	23/10	2.6/10.0
MP	1,450	14	1 1/8	0.37/0.011	200/91	25/11	2.9/11.0
MP	1,600	22	1 1/8	0.37/0.011	200/91	25/11	2.9/11.0
MP	1,700	16	1 1/8	0.40/0.011	270/122	25/11	2.9/11.0
MP	1,900	14	1 1/8	0.52/0.015	300/136	34/16	4.0/15.0
MP	2,175	22	1 3/8	0.55/0.016	300/136	37/17	4.2/16.0
MP	2,400	11	1 3/8	0.90/0.025	330/150	57/26	6.6/25.0
MP	2,850	11	1 3/8	1.16/0.033	365/166	76/34	8.7/33.0
MP	3,100	14	1 3/8	1.31/0.037	410/186	85/38	9.8/37.0

Notes:

*Based on 35% (by volume) Propylene Glycol

MEDIUM PROFILE

Glycol Models Physical Data

Model	No. of Fans	Coil Data					Condensate Drain	Defrost Type	Approx. Net Wt. Lbs.	Approx. Gross Wt. Lbs.
		FPI	Tube OD	# of Circuits	Connections OD	Finned Length				
*EM0900^G6A+A	1	6	3/8	11	7/8	28	3/4 FPT	Air	160	270
*EM1100^G6A+A	2	6	3/8	11	7/8	56	3/4 FPT	Air	180	330
*EM1275^G6A+A	2	6	3/8	11	7/8	56	3/4 FPT	Air	200	350
*EM1450^G6A+A	2	6	3/8	14	1 1/8	56	3/4 FPT	Air	200	350
*EM1600^G6A+A	2	6	3/8	22	1 1/8	56	3/4 FPT	Air	200	350
*EM1700^G6A+A	3	6	3/8	16	1 1/8	84	3/4 FPT	Air	270	450
*EM1900^G6A+A	3	6	3/8	14	1 1/8	84	3/4 FPT	Air	300	480
*EM2175^G6A+A	3	6	3/8	22	1 3/8	84	3/4 FPT	Air	300	480
*EM2400^G6A+A	4	6	1/2	11	1 3/8	112	3/4 FPT	Air	330	560
*EM2850^G6A+A	4	6	1/2	11	1 3/8	112	3/4 FPT	Air	365	590
*EM3100^G6A+A	5	6	1/2	14	1 3/8	127.5	3/4 FPT	Air	410	670

Notes:

^ Electrical Code (A = 115/1/60, B = 208-230/1/60, M = 460/1/60, L = 575/1/60)

+ Motor Code (P = PSC, C = PSC Totally Enclosed, E = Fixed Speed EC)

MEDIUM PROFILE

Dimensional Data

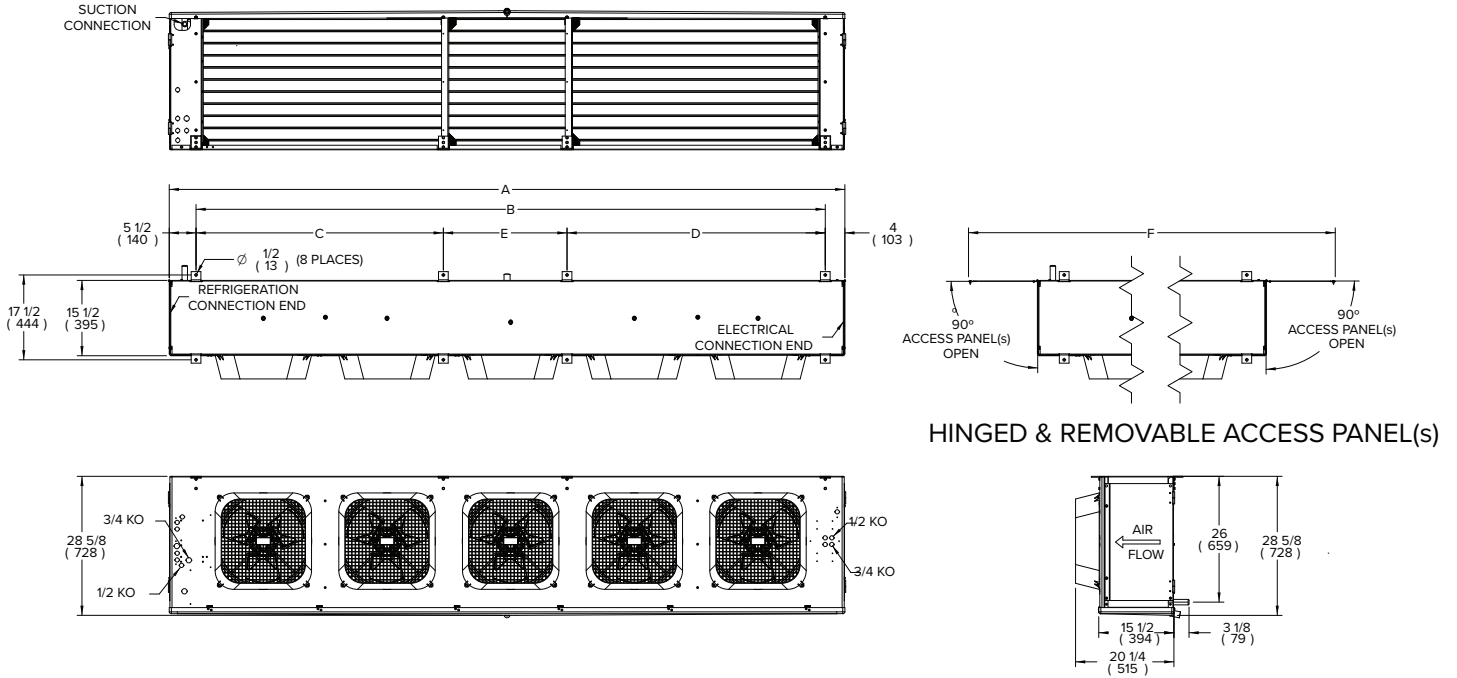

No. of Fans	Dimensions (Inches, mm)					
	A	B	C	D	E	F
1	39-7/8 (1011)	30-1/4 (768)	-	-	-	68-1/4 (1733)
2	67-7/8 (1722)	58-1/4 (1480)	-	-	-	96-1/4 (2444)
3	95-7/8 (2434)	86-1/4 (2191)	-	-	-	124-1/4 (3155)
4	123-7/8 (3145)	114-1/4 (2902)	56 (1422)	58-1/4 (1480)	-	152-1/4 (3866)
5	139-3/8 (3539)	129-3/4 (3296)	51 (1295)	53-1/4 (1353)	25-1/2 (648)	167-3/4 (4260)

No. of Fans	Ship Dimensions (Inches, mm)		
	Height	Length	Width
1	39 (991)	48-1/2 (1232)	30 (792)
2	39 (991)	78 (1981)	30 (792)
3	39 (991)	106 (2692)	30 (792)
4	39 (991)	134 (3404)	30 (792)
5	39 (991)	149 (3785)	30 (792)

Notes:

^ Electrical code (A = 115/1/60 or B = 208-230/1/60)

* Glycol available in all Brands (Bohn, Larkin, Climate Control & Chandler)

REPLACEMENT PARTS

LOP Glycol Unit Coolers

Product Family	Fan Std/ Rev Air	Fan Guard Molded/ Wire	Motor 115V 1 SP/2 SP EC	Motor 208-230V 2 SP EC	Motor 208-230V 1 SP EC	Motor 115V PSC TE	Motor 208-230V PSC TE	Motor 460V PSC TE	Motor Mount 115V 208-230V	Motor Mount 460V	Motor Mount
LOP	5140C/ 5110E	37001701/ 37001601	25329001S/ 25312501S	25329101S/ 25312601S	25317701S	25309501S	25309801S	25309701S	23106301	23106401	5064E

P/N	Conn Size	Description
29315801	1/8 MPT x 1/4 FL	Vent / Drain Valve
29320305	5/8 ODF	Balance Valve 1/2
29320304	7/8 ODF	Balance Valve 3/4
29320301	1-1/8 ODF	Balance Valve 1
29320302	1-3/8 ODF	Balance Valve 1-1/4
29320405	5/8 ODF	Shut-Off Valve 1/2
29320404	7/8 ODF	Shut-Off Valve 3/4
29320401	1-1/8 ODF	Shut-Off Valve 1
29320402	1-3/8 ODF	Shut-Off Valve 1-1/4
26925101	3/4 - 14	Drain Fitting Kit

REPLACEMENT PARTS

LOP Cabinet Components

Part #	No. of Fans	Description	Defrost Type	Cabinet Aluminum
40594101	1	DRAIN PAN	AIR	ALUMINUM
40595101	1	DRAIN PAN	AIR	WHITE PAINTED ALUMINUM
40596101	1	DRAIN PAN	AIR	STAINLESS STEEL
40594201	2	DRAIN PAN	AIR	ALUMINUM
40595201	2	DRAIN PAN	AIR	WHITE PAINTED ALUMINUM
40596201	2	DRAIN PAN	AIR	STAINLESS STEEL
40594301	3	DRAIN PAN	AIR	ALUMINUM
40595301	4	DRAIN PAN	AIR	WHITE PAINTED ALUMINUM
40596301	4	DRAIN PAN	AIR	STAINLESS STEEL
40594401	4	DRAIN PAN	AIR	ALUMINUM
40595401	4	DRAIN PAN	AIR	WHITE PAINTED ALUMINUM
40596401	4	DRAIN PAN	AIR	STAINLESS STEEL
40594501	5	DRAIN PAN	AIR	ALUMINUM
40595501	5	DRAIN PAN	AIR	WHITE PAINTED ALUMINUM
40596501	5	DRAIN PAN	AIR	STAINLESS STEEL
40594601	6	DRAIN PAN	AIR	ALUMINUM
40595601	6	DRAIN PAN	AIR	WHITE PAINTED ALUMINUM
40596601	6	DRAIN PAN	AIR	STAINLESS STEEL
40594102	1	DRAIN PAN	ELECTRIC	ALUMINUM
40595102	1	DRAIN PAN	ELECTRIC	WHITE PAINTED ALUMINUM
40594202	2	DRAIN PAN	ELECTRIC	ALUMINUM
40595202	2	DRAIN PAN	ELECTRIC	WHITE PAINTED ALUMINUM
40594302	3	DRAIN PAN	ELECTRIC	ALUMINUM
40595302	3	DRAIN PAN	ELECTRIC	WHITE PAINTED ALUMINUM
40594402	4	DRAIN PAN	ELECTRIC	ALUMINUM
40595402	4	DRAIN PAN	ELECTRIC	WHITE PAINTED ALUMINUM
40594502	5	DRAIN PAN	ELECTRIC	ALUMINUM
40595502	5	DRAIN PAN	ELECTRIC	WHITE PAINTED ALUMINUM
40594602	6	DRAIN PAN	ELECTRIC	ALUMINUM
40595602	6	DRAIN PAN	ELECTRIC	WHITE PAINTED ALUMINUM

REPLACEMENT PARTS

LOP Cabinet Components (cont.)

Part #	No. of Fans	Description	Defrost Type	Cabinet Aluminum
40593703	1	INSULATED OUTER DRAIN PAN ASSY	ALL	ALUMINUM
40593704	1	INSULATED OUTER DRAIN PAN ASSY	ALL	WHITE PAINTED ALUMINUM
40593002	1	INSULATED OUTER DRAIN PAN ASSY	ALL	STAINLESS STEEL
40593803	2	INSULATED OUTER DRAIN PAN ASSY	ALL	ALUMINUM
40593804	2	INSULATED OUTER DRAIN PAN ASSY	ALL	WHITE PAINTED ALUMINUM
40593102	2	INSULATED OUTER DRAIN PAN ASSY	ALL	STAINLESS STEEL
40591503	3	INSULATED OUTER DRAIN PAN ASSY	ALL	ALUMINUM
40591504	3	INSULATED OUTER DRAIN PAN ASSY	ALL	WHITE PAINTED ALUMINUM
40593202	3	INSULATED OUTER DRAIN PAN ASSY	ALL	STAINLESS STEEL
40591603	4	INSULATED OUTER DRAIN PAN ASSY	ALL	ALUMINUM
40591604	4	INSULATED OUTER DRAIN PAN ASSY	ALL	WHITE PAINTED ALUMINUM
40593302	4	INSULATED OUTER DRAIN PAN ASSY	ALL	STAINLESS STEEL
40591703	5	INSULATED OUTER DRAIN PAN ASSY	ALL	ALUMINUM
40591704	5	INSULATED OUTER DRAIN PAN ASSY	ALL	WHITE PAINTED ALUMINUM
40593402	5	INSULATED OUTER DRAIN PAN ASSY	ALL	STAINLESS STEEL
40591803	6	INSULATED OUTER DRAIN PAN ASSY	ALL	ALUMINUM
40591804	6	INSULATED OUTER DRAIN PAN ASSY	ALL	WHITE PAINTED ALUMINUM
40593502	6	INSULATED OUTER DRAIN PAN ASSY	ALL	STAINLESS STEEL
41038701	ALL	ACCESS PANEL RH (ELEC) END	ALL	ALUMINUM
41038702	ALL	ACCESS PANEL RH (ELEC) END	ALL	WHITE PAINTED ALUMINUM
41038901	ALL	ACCESS PANEL RH (ELEC) END	ALL	STAINLESS STEEL
41038401	ALL	ACCESS PANEL LH (REFRIG) END	ALL	ALUMINUM
41038402	ALL	ACCESS PANEL LH (REFRIG) END	ALL	WHITE PAINTED ALUMINUM
41038501	ALL	ACCESS PANEL LH (REFRIG) END	ALL	STAINLESS STEEL
40593302	4	INSULATED OUTER DRAIN PAN ASSY	ALL	STAINLESS STEEL
40591703	5	INSULATED OUTER DRAIN PAN ASSY	ALL	ALUMINUM
40591704	5	INSULATED OUTER DRAIN PAN ASSY	ALL	WHITE PAINTED ALUMINUM
40593402	5	INSULATED OUTER DRAIN PAN ASSY	ALL	STAINLESS STEEL
40591803	6	INSULATED OUTER DRAIN PAN ASSY	ALL	ALUMINUM
40591804	6	INSULATED OUTER DRAIN PAN ASSY	ALL	WHITE PAINTED ALUMINUM
40593502	6	INSULATED OUTER DRAIN PAN ASSY	ALL	STAINLESS STEEL
41038701	ALL	ACCESS PANEL RH (ELEC) END	ALL	ALUMINUM
41038702	ALL	ACCESS PANEL RH (ELEC) END	ALL	WHITE PAINTED ALUMINUM
41038901	ALL	ACCESS PANEL RH (ELEC) END	ALL	STAINLESS STEEL
41038401	ALL	ACCESS PANEL LH (REFRIG) END	ALL	ALUMINUM
41038402	ALL	ACCESS PANEL LH (REFRIG) END	ALL	WHITE PAINTED ALUMINUM
41038501	ALL	ACCESS PANEL LH (REFRIG) END	ALL	STAINLESS STEEL

REPLACEMENT PARTS

LOP Drain Pan Heaters

Part #	No. of Fans	Voltage	Wattage	Defrost Type
24752501	1	230	150	ELECTRIC
24752502	2	230	300	ELECTRIC
24752503	3	230	450	ELECTRIC
24752504	4	230	600	ELECTRIC
24752505	5	230	750	ELECTRIC
24752506	6	230	900	ELECTRIC

LOP Coil Defrost Heaters

Part #	No. of Fans	Voltage	Wattage	Defrost Type
24752001	1	230	300	ELECTRIC
24752002	2	230	600	ELECTRIC
24752003	3	230	900	ELECTRIC
24752004	4	230	1,200	ELECTRIC
24752005	5	230	1,500	ELECTRIC
24752006	6	230	1,800	ELECTRIC
24754101	1	230	150	ELECTRIC
24753302	2	460	600	ELECTRIC
24753303	3	460	900	ELECTRIC
24753304	4	460	1,200	ELECTRIC
24753305	5	460	1,500	ELECTRIC
24753306	6	460	1,800	ELECTRIC

REPLACEMENT PARTS

CM Glycol Unit Coolers

Product Family	Fan	Fan Guard	Motor 115V EC	Motor 208-230V EC	Motor Mount Plate
CM	5110E	23106201	25329001S	25329101S	41417501

P/N	Conn Size	Description
29315801	1/8 MPT x 1/4 FL	Vent / Drain Valve
29320305	5/8 ODF	Balance Valve 1/2
29320304	7/8 ODF	Balance Valve 3/4
29320301	1-1/8 ODF	Balance Valve 1
29320405	5/8 ODF	Shut-Off Valve 1/2
29320404	7/8 ODF	Shut-Off Valve 3/4
29320401	1-1/8 ODF	Shut-Off Valve 1

REPLACEMENT PARTS

LVCM Glycol Unit Coolers

Product Family	Fan	Fan Guard	Motor 115V EC	Motor 208-230V EC	Motor Mount Plate
LVCM	5110E	23106201	25329001S	25329101S	41417501

Product Family	Elec. and W.F. Defrost Model Size	Coil/Drain Pan Heater	Heater and Fan Control
LVCM	0400	4548B	4267W
LVCM	0500	4548B	4267W
LVCM	0750	4549B	4267W
LVCM	0950	4549B	4267W
LVCM	1100	4544B	4267W
LVCM	1400	4544B	4267W
LVCM	1650	4545B	4267W

P/N	Conn Size	Description
29315801	1/8 MPT x 1/4 FL	Vent / Drain Valve
29320305	5/8 ODF	Balance Valve 1/2
29320304	7/8 ODF	Balance Valve 3/4
29320301	1-1/8 ODF	Balance Valve 1
29320405	5/8 ODF	Shut-Off Valve 1/2
29320404	7/8 ODF	Shut-Off Valve 3/4
29320401	1-1/8 ODF	Shut-Off Valve 1

REPLACEMENT PARTS

MP Glycol Unit Coolers

Product Family	Fan Std/ Rev Air	Fan Guard Molded/ Wire	Motor 115V PSC	Motor 208-230V PSC	Motor 460V PSC	Motor 575V PSC	Motor 208- 230V PSC TE	Motor 460V PSC TE	Motor 115V EC 1 Speed	Motor 208-230V EC 1 Speed	Motor Mount
MP	22902401	2310022/ 23101802	5020S	5020T	25302201	25399301	4567T	25304601	25317601	25317501	5064E

P/N	Conn Size	Description
29315801	1/8 MPT x 1/4 FL	Vent / Drain Valve
29320304	7/8 ODF	Balance Valve 3/4
29320301	1-1/8 ODF	Balance Valve 1
29320302	1-3/8 ODF	Balance Valve 1-1/4
29320404	7/8 ODF	Shut-Off Valve 3/4
29320401	1-1/8 ODF	Shut-Off Valve 1
29320402	1-3/8 ODF	Shut-Off Valve 1-1/4
26930801	3/4 - 14	FITTING 3/4-14 NPSM

■ **NOTES**



2175 West Park Place Blvd.

Stone Mountain, GA 30087

Phone: 800.537.7775 · Fax: 770.465.5900

heatcraftprd.com

Since product improvement is a continuing effort, we reserve the right to make changes in specifications without notice.

CH-GUC-0722 | Version 003

©2020 Heatcraft Refrigeration Products LLC