

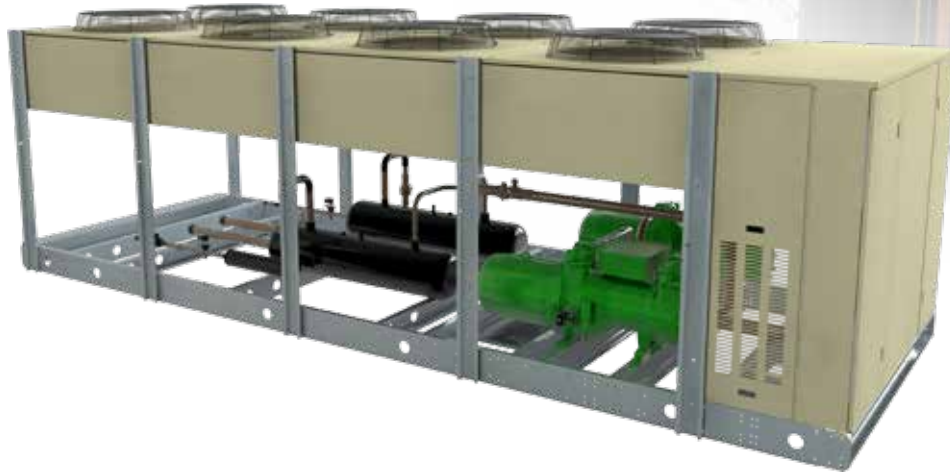

*Air-Cooled Condensing Units
with Compact Screw Compressors*

Technical Bulletin
Models SSV | DSV



BOHN

Table of Contents

Nomenclature Chart	2
Introduction	3
Bitzer™ Compressors	4
Magnum™ Microprocessor	5
Condenser Features	6
Unit Features and Options	7
Performance Data	8
Medium Temperature	8-9
R-404A/R-507	8
R-407C	9
High Temperature	10
R-407C	10
Physical Data	11
Dimensional Drawings	11
Electrical Data	12-13

Nomenclature						
S	S	V	000B	M	6	D
Number of Circuits	Compressor Style	Airflow	Horsepower	Temp. Range	Refrigerant Type	Voltage
S = Single	S = Screw	V = Vertical	050B – 50	M = Medium	6 = R-404A,	D = 460/3/60
D = Dual			060B – 60	H = High	R-507	E = 575/3/60
			070B – 70		7 = R-407c	
			080B – 80			
			090B – 90			
			100B - 100			
			110B - 110			
			125B - 125			
			140B - 140			

THE RIGHT CHOICE FOR LARGE COOLING APPLICATIONS

The screw compressor condensing unit is an important addition to the Heatcraft air-cooled condensing unit product family, featuring innovative compact screw compressors and advanced microprocessor controls. The unit is designed to provide increased system reliability, reduced installation and operation costs, as well as, improved product integrity in commercial and industrial refrigeration applications.

Increased Reliability

The Heatcraft screw compressor condensing unit is a reliable and rugged system, designed for the commercial and industrial refrigeration markets. Compact screw compressors have fewer moving parts than reciprocating compressors, resulting in improved durability. Additionally, a semi-hermetic motor design eliminates shaft seal and coupling concerns, while an integral oil system provides improved lubrication performance. The screw compressors utilize slide valve unloading which increases motor life through unloaded compressor starting. The new screw condensing units are factory equipped with an advanced microprocessor control system. This control system constantly monitors and adapts by modifying multiple parameters to guarantee safe and reliable system performance. Finally, all screw compressor condensing units come standard with a floating tube condenser coil design, minimizing the potential for refrigerant leaks.

Reduced Costs of Ownership

Screw compressor condensing units allow owners and operators to reduce both their installation and operating costs. Screw compressor condensing units yield more capacity per compressor than traditional reciprocating compressor condensing units. The result is a reduced number of units on large projects and subsequent savings of time and cost during installation and commissioning. Built-in features such as soft starting, slide valve unloading, and digital controls make Heatcraft screw compressor condensing units the optimum choice for maximum performance with minimal operating costs.

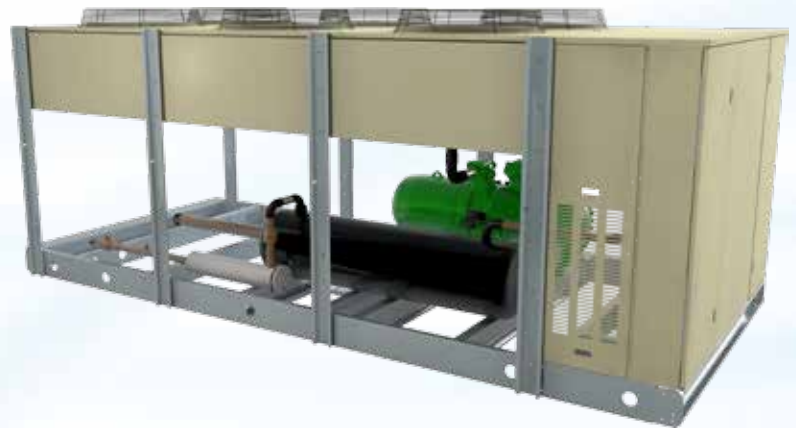

Improved Product Integrity

With advanced digital controls and variable capacity capability, the screw compressor condensing units have the capability to maintain more precise temperature control and stable product environment. Minimizing temperature fluctuations results in maximum product integrity; all while maintaining overall system performance. Screw compressor condensing units are the right choice and the perfect match for large, mission critical cooling applications.



Compact Screw Compressors

The Bitzer CSH compact screw compressor is the result of continuous development for a simplified, space and energy efficient semi-hermetic screw compressor. Using state of the art technology, this screw compressor is not only smooth running, quiet, and efficient; but also meets the same stringent performance and reliability benchmarks that have set the industry standard.



Robust Design

The compact screw compressors feature a newly developed efficient twin rotor geometry. The rotors are precisely located at both ends by bearings that prevent radial and axial movement reducing unit vibration. Rotors and housing are machined for tight tolerances allowing optimum efficiency while preventing wear. Compressors are constructed with a double wall rotor casing for reduced sound transmission. Rotor and casing design, in conjunction with oversized oil supply chambers, result in a significantly more robust compressor.



Optimized Oil Management

The compact screw compressors are designed with an integral three-stage oil separator and a 10-micron oil filter. Oil system also includes an oil level control, oil level sight glass, crankcase oil heater, and an oil service valve. The integral oil system reduces the system piping complexity, and subsequently minimizes potential leak points.

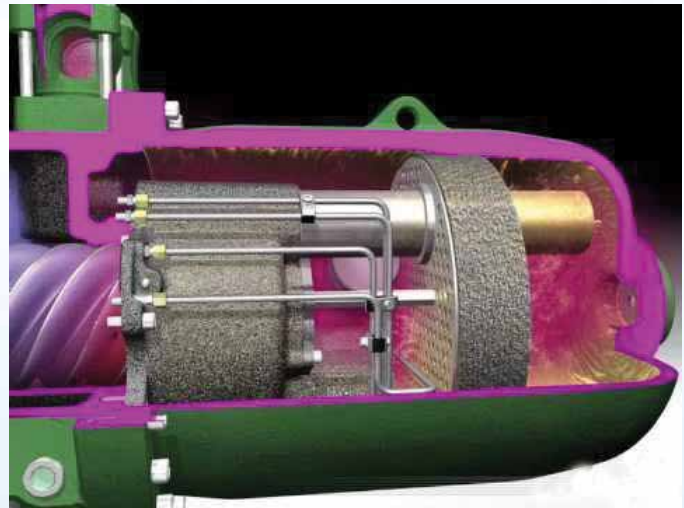

MICROPROCESSOR CONTROLLER: FEATURES AND BENEFITS

Magnum™ Microprocessor

The Magnum™ microprocessor control produces a more stable operating system resulting in precise process and product temperatures improving product integrity. Advanced control algorithms provide for proper compressor control resulting in more efficient operation and longer compressor life. The microprocessor is factory installed and features pre-loaded factory set points allowing for faster startup and commissioning. Advanced diagnostic, monitoring, and data logging options assist in efficient trouble shooting should an issue arise, minimizing costs and allowing quick system recovery.

Microprocessor monitors and controls:

- Room temperature
- Compressor Suction Temperature
- Compressor Discharge Temperature
- Compressor Suction Pressure
- Compressor Discharge Pressure
- Compressor Amps
- Defrost Time Schedules
- Defrost Termination (Electric Defrost Equipped Models)
- Evaporator Fan Delay (Electric Defrost Equipped Models)
- Evaporator Defrost Hold Out (Electric Defrost Equipped Models)

In addition, microprocessor controls:

- Compressor Slide Valve
- Compressor Unloaded Start
- Condenser Fan Cycling
- Pre-Start System Pumpdown

Finally, the Magnum™ monitors:

- Ambient Temperature
- Compressor Module
- Phase Loss Monitor
- Optical Oil Level Control
- Compressor Run time
- Compressor Cycles
- Alarms and Error Codes

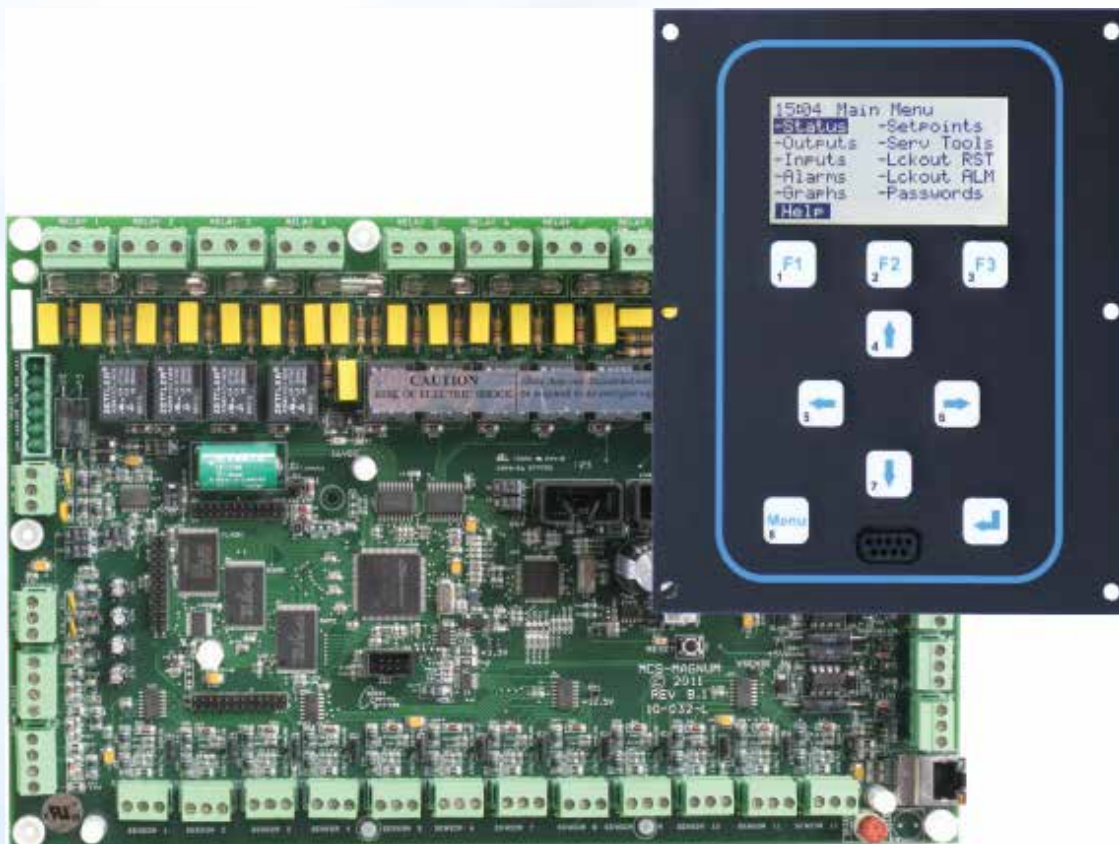

Floating Tube™ Coil Design

Expanded (Locked) Auxiliary Tubes

These tubes do not carry refrigerant and are in place to support the fin pack and the tubes that are carrying refrigerant. They are expanded into the end and center supports.

Free Floating Circuited Coil Tubes

These tubes carry refrigerant and never contact any sheet metal (end supports and center supports).

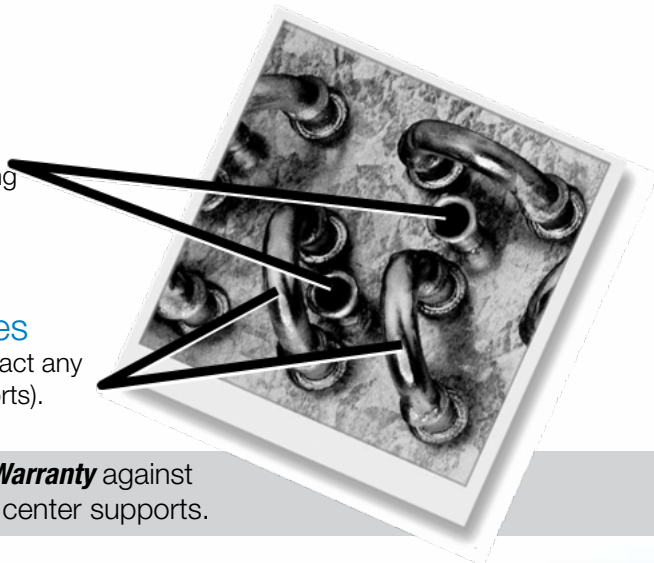

All units include a limited **Five Year Warranty** against condenser leaks at tube sheets and center supports.

All SSV/DSV condensers use the Floating Tube™ coil design to eliminate refrigerant leaks at the tube sheets. Additional anchor tubes are added to the condenser coil. Anchor tubes are expanded into the aluminum fins and condenser tube sheets. These tubes support the weight of the coil, but are not a part of the refrigerant circuit.

The tubes in the refrigerant circuit are expanded into the fins, but “float” through oversized holes in the tube sheets. Tube sheet leaks are virtually eliminated, since the tubes which carry refrigerant never come in contact with the tube sheet.

Adjustable Flooding Head Pressure Control

The Need For Head Pressure Control

Refrigeration condensing units must efficiently perform at varying ambient conditions. A properly sized unit will adequately perform at the highest summer ambient temperatures. However, in situations where the system must operate the majority of the time at less than design temperature, a means of providing adequate head pressure for refrigerant flow is desirable.

Adjustable Two Valve Flooded Head Pressure Control

The screw compressor condensing units use a factory assembled system utilizing an adjustable two valve flooding head pressure control scheme to maintain a constant head pressure at the air-cooled condensing unit during all climatic conditions when the ambient temperature drops below 75°F (typical).

When the ambient is above 75°F, the condenser pressure is above the drain regulator setting; therefore, the valve remains in the full open position.

As the temperature drops below 75°F, the pressure at the condenser also drops below the setting of the drain regulator. The drain regulator, sensing the reduction in condensing pressure, modulates toward the closed position, thus restricting the flow of liquid from the condenser. The liquid backs up into the condenser and floods a portion of the tubes, reducing the overall capacity of the condenser. The drain regulator valve will continue to flood the condenser until the pressure setting has been reached, providing proper head pressure at all ambient temperatures.

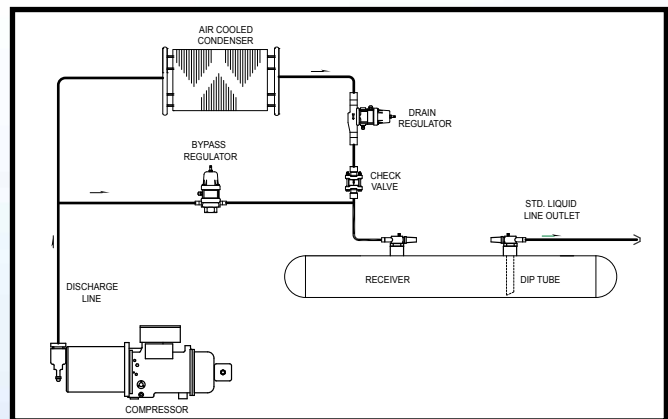

While the condenser floods, a second line pressurizes the receiver through the bypass regulator; therefore, the refrigerant flow from the condenser to the receiver modulates with conditions. However, the bypass from the discharge line maintains a minimum receiver pressure. These valves are adjustable and the minimum receiver pressure may be reset higher or lower depending upon application situations of a particular job.

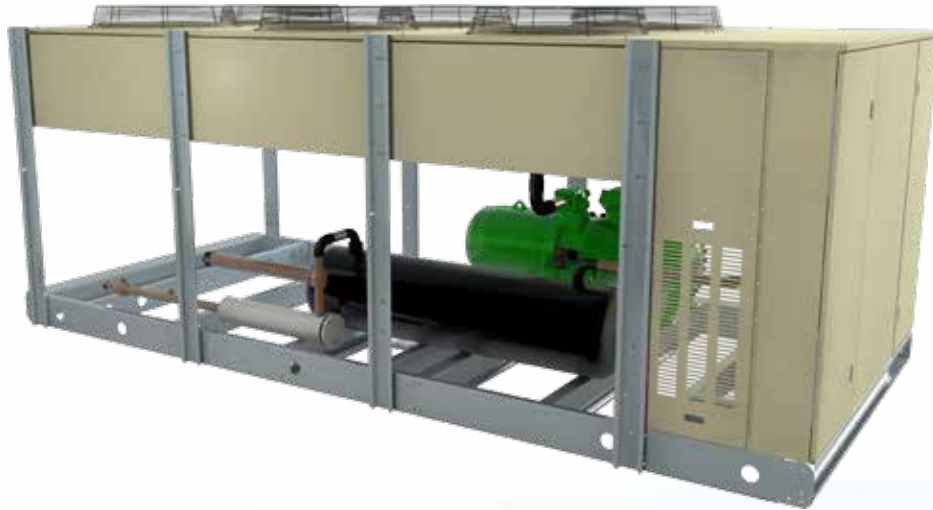

Standard Features

- Compact screw compressor(s) with slide valve unloading, integral discharge check valve, suction and discharge service valves and internal pressure relief valve. Compressor(s) include an integral oil system(s) including oil separator, oil filter, oil sight glass, oil service valve, crankcase heater and POE oil charge
- Floating Tube™ coil design. Refrigerant-carrying copper tubes do not contact any metal support sheets; instead, the coil is constructed with expanded anchor tubes that support the coil construction and do not carry refrigerant. The coil design eliminates one of the major causes of leaks in refrigeration systems
- Limited five-year warranty against condenser tube sheet and center support leaks
- Thermally protected, permanently lubricated ball bearing condenser fan motors
- Adjustable two valve head pressure control system including drain line check valve
- Receiver(s) are sized for sufficient pumpdown capacity with inlet and outlet service valves
- Dual pressure relief valves on receiver(s)
- Replaceable core liquid line filter drier(s) and sight glass(es)
- ETL listed control panel including:
 - Microprocessor unit controller including room temperature control, compressor slide valve control, condenser fan cycling control and pre-start system pumpdown
 - Control power transformer with fusing
 - Control circuit breaker
 - Phase loss monitor
 - Compressor contactor(s) with overloads
 - Condenser fan motor contactors with fusing
 - Suction and discharge pressure transducers
 - Suction, discharge, ambient and room temperature sensors
 - Pumpdown switch
 - Emergency stop switch
 - Compressor module

- All sweat type connections, no flare joints to leak
- Cabinet is constructed from prepainted galvanized steel
- Designed for use with R-404A, R-507 and R407C

Factory-Installed Options

- Replaceable core suction filter(s)
- Suction accumulator(s)
- Liquid line solenoid valve(s)
- Electric defrost kits including evaporator fan contactor(s) with fusing, defrost heater contactor(s) with fusing, and terminal strip
- Low ambient kit(s) with heated and insulated receiver
- Unit circuit breaker with thru the door actuator
- Variable speed EC condenser fan motors
- Three-way heat reclaim valve(s)
- Coated condenser coils for protection against corrosion in harsh environments

PERFORMANCE DATA

Medium Temperature Models | R404A/R507 Compressors

R404A/R507 Model	Compressor		Capacity BTUH @ 90°F Ambient by SST				
	Part #	Quantity	30°F BTUH	25°F BTUH	20°F BTUH	15°F BTUH	10°F BTUH
SSV050BM6^	CHS6553-50Y	1	426525	393813	363006	332056	303973
SSV060BM6^	CHS6563-60Y	1	543525	503973	462386	423871	387859
SSV070BM6^	CSH7553-70Y	1	622014	574097	528164	484458	440827
SSV080BM6^	CHS7563-80Y	1	696205	643955	593700	544083	496633
SSV090BM6^	CSH7573-90Y	1	815887	756334	699180	641772	587789
SSV110BM6^	CHS8553-110Y	1	1023199	949621	878343	808283	741392
SSV125BM6^	CHS8563-125Y	1	1154422	1074877	993550	918916	841393
SSV140BM6^	CHS8573-140Y	1	1331213	1236939	1141633	1055481	967417
DSV100BM6^	CHS6553-50Y	2	861394	794350	730996	670320	613636
DSV120BM6^	CHS6563-60Y	2	1078138	996222	917554	842504	767904
DSV140BM6^	CSH7553-70Y	2	1242424	1146246	1055194	966318	881424

R404A/R507 Model	Compressor		Capacity BTUH @ 95°F Ambient by SST				
	Part #	Quantity	30°F BTUH	25°F BTUH	20°F BTUH	15°F BTUH	10°F BTUH
SSV050BM6^	CHS6553-50Y	1	404784	373015	343013	313930	287068
SSV060BM6^	CHS6563-60Y	1	518168	477242	438588	401473	366973
SSV070BM6^	CSH7553-70Y	1	589053	544398	499035	456961	417445
SSV080BM6^	CHS7563-80Y	1	657680	606551	559491	512614	468130
SSV090BM6^	CSH7573-90Y	1	771500	715961	660034	606819	555496
SSV110BM6^	CHS8553-110Y	1	972571	900032	834508	766274	702090
SSV125BM6^	CHS8563-125Y	1	1098981	1020599	943943	868537	797484
SSV140BM6^	CHS8573-140Y	1	1265976	1174734	1084562	999313	915316
DSV100BM6^	CHS6553-50Y	2	816016	755440	692834	634288	580026
DSV120BM6^	CHS6563-60Y	2	1024550	947130	868932	796000	726238
DSV140BM6^	CSH7553-70Y	2	1175996	1086180	997486	914814	831490

R404A/R507 Model	Compressor		Capacity BTUH @ 100°F Ambient by SST				
	Part #	Quantity	30°F BTUH	25°F BTUH	20°F BTUH	15°F BTUH	10°F BTUH
SSV050BM6^	CHS6553-50Y	1	382685	352929	323395	295526	269861
SSV060BM6^	CHS6563-60Y	1	490309	451308	414231	379573	345415
SSV070BM6^	CSH7553-70Y	1	555027	511972	470456	430382	392979
SSV080BM6^	CHS7563-80Y	1	618769	570745	525419	481801	439662
SSV090BM6^	CSH7573-90Y	1	727485	675373	621970	571548	524223
SSV110BM6^	CHS8553-110Y	1	921835	855696	788019	724062	662735
SSV125BM6^	CHS8563-125Y	1	1039703	962016	891734	820502	752349
SSV140BM6^	CHS8573-140Y	1	1200015	1112179	1025235	943363	864308
DSV100BM6^	CHS6553-50Y	2	774864	712518	653848	599140	545750
DSV120BM6^	CHS6563-60Y	2	968138	894046	820724	750626	685250
DSV140BM6^	CSH7553-70Y	2	1106852	1022564	940964	858914	782564

Notes

Allowable Capacity Reduction

25%	75%
50%	No Unloading

Allowable unit capacity reduction will vary depending upon actual operating conditions. Shading represents expected capacity reduction at given operating conditions. Additional capacity reduction may be realized during low ambient or reduced load situations. Unit microprocessor will increase capacity reduction as operating conditions allow.

^ = Placeholder for voltage code (D or E)

PERFORMANCE DATA

Medium Temperature Models | R407C Compressors

R407C Model	Compressor		Capacity BTUH @ 90°F Ambient by SST				
	Part #	Quantity	30°F BTUH	25°F BTUH	20°F BTUH"	15°F BTUH	10°F BTUH
SSV050BM7^	CHS6553-50Y	1	386365	352990	321034	290863	262280
SSV060BM7^	CHS6563-60Y	1	493154	449269	408544	370617	333312
SSV070BM7^	CSH7553-70Y	1	564712	515134	467560	423248	380699
SSV080BM7^	CHS7563-80Y	1	637661	581135	528527	478121	430776
SSV090BM7^	CSH7573-90Y	1	745656	684741	623891	566345	510328
SSV100BM7^	CSH7583-100Y	1	868350	795016	728430	662953	600354
SSV110BM7^	CHS8553-110Y	1	981154	900158	822278	749184	680657
SSV125BM7^	CHS8563Y-125	1	1154422	1074877	993550	918916	841393
SSV140BM7^	CHS8573-140Y	1	1229670	1127670	1027693	937122	847263
DSV100BM7^	CHS6553-50Y	2	979650	897252	816938	740308	668068
DSV120BM7^	CHS6563-60Y	2	979650	897252	816938	740308	668068
DSV140BM7^	CSH7553-70Y	2	1137044	1037494	942276	851880	766882

R407C Model	Compressor		Capacity BTUH @ 95°F Ambient by SST				
	Part #	Quantity	30°F BTUH	25°F BTUH	20°F BTUH	15°F BTUH	10°F BTUH
SSV050BM7^	CHS6553-50Y	1	369024	336625	305822	276577	249590
SSV060BM7^	CHS6563-60Y	1	470481	429369	390074	353056	317028
SSV070BM7^	CSH7553-70Y	1	539547	491486	446650	402461	361638
SSV080BM7^	CHS7563-80Y	1	605865	554757	504194	454673	410224
SSV090BM7^	CSH7573-90Y	1	712402	654200	595741	539260	486581
SSV100BM7^	CSH7583-100Y	1	829650	763518	697500	633554	575108
SSV110BM7^	CHS8553-110Y	1	941764	863955	786942	718157	649336
SSV125BM7^	CHS8563Y-125	1	1098981	1020599	943943	868537	797484
SSV140BM7^	CHS8573-140Y	1	1178594	1080735	986291	894641	811338
DSV100BM7^	CHS6553-50Y	2	939514	857670	778164	704122	634518
DSV120BM7^	CHS6563-60Y	2	939514	857670	778164	704122	634518
DSV140BM7^	CSH7553-70Y	2	1086050	987306	898546	811978	730376

R407C Model	Compressor		Capacity BTUH @ 100°F Ambient by SST				
	Part #	Quantity	30°F BTUH	25°F BTUH	20°F BTUH	15°F BTUH	10°F BTUH
SSV050BM7^	CHS6553-50Y	1	350823	319798	290657	261749	235110
SSV060BM7^	CHS6563-60Y	1	448429	409406	370264	334164	299971
SSV070BM7^	CSH7553-70Y	1	513775	467612	424665	382159	343126
SSV080BM7^	CHS7563-80Y	1	577665	525386	478024	430973	388461
SSV090BM7^	CSH7573-90Y	1	680744	622807	565912	512604	462311
SSV100BM7^	CSH7583-100Y	1	792215	727045	665512	606003	548674
SSV110BM7^	CHS8553-110Y	1	900483	822962	751417	684622	619701
SSV125BM7^	CHS8563Y-125	1	1039703	962016	891734	820502	752349
SSV140BM7^	CHS8573-140Y	1	1127175	1032330	939678	853159	772657
DSV100BM7^	CHS6553-50Y	2	895454	814250	739016	669488	602046
DSV120BM7^	CHS6563-60Y	2	895454	814250	739016	669488	602046
DSV140BM7^	CSH7553-70Y	2	1034062	939404	854686	769704	691728

Notes

Allowable Capacity Reduction

25%	75%
50%	No Unloading

Allowable unit capacity reduction will vary depending upon actual operating conditions. Shading represents expected capacity reduction at given operating conditions. Additional capacity reduction may be realized during low ambient or reduced load situations. Unit microprocessor will increase capacity reduction as operating conditions allow.

^ = Placeholder for voltage code (D or E)

High Temperature Models | R407C Compressors

R407C Model	Compressor		Capacity BTUH @ 90°F Ambient by SST			
	Part #	Quantity	45°F BTUH ¹	40°F BTUH	35°F BTUH	30°F BTUH
SSV050BH7^	CHS6553-50Y	1	533290	491102	451123	411747
SSV060BH7^	CHS6563-60Y	1	678277	624234	572483	523026
SSV070BH7^	CSH7553-70Y	1	793828	730586	668119	608723
SSV080BH7^	CHS7563-80Y	1	897646	826735	756193	691303
SSV090BH7^	CSH7573-90Y	1	991672	916697	845911	775591
SSV100BH7^	CSH7583-100Y	1	1201615	1109570	1022540	936926

R407C Model	Compressor		Capacity BTUH @ 95°F Ambient by SST			
	Part #	Quantity	45°F BTUH	40°F BTUH	35°F BTUH	30°F BTUH
SSV050BH7^	CHS6553-50Y	1	513882	472794	433412	395703
SSV060BH7^	CHS6563-60Y	1	653040	601671	550304	503119
SSV070BH7^	CSH7553-70Y	1	762872	699213	640040	581990
SSV080BH7^	CHS7563-80Y	1	860965	791518	724481	660772
SSV090BH7^	CSH7573-90Y	1	949863	880409	810138	741297
SSV100BH7^	CSH7583-100Y	1	1157353	1067426	983045	899775
DSV100BH7^	CHS6553-50Y	2	1034968	952384	871956	798064

R407C Model	Compressor		Capacity BTUH @ 100°F Ambient by SST			
	Part #	Quantity	45°F BTUH	40°F BTUH	35°F BTUH	30°F BTUH
SSV050BH7^	CHS6553-50Y	1	492773	453010	413935	378110
SSV060BH7^	CHS6563-60Y	1	627132	577170	528219	480718
SSV070BH7^	CSH7553-70Y	1	729761	668320	611636	556657
SSV080BH7^	CHS7563-80Y	1	820192	753818	691032	629943
SSV090BH7^	CSH7573-90Y	1	907503	840717	772056	708906
SSV100BH7^	CSH7583-100Y	1	1111034	1025251	941595	864087
DSV100BH7^	CHS6553-50Y	2	991456	911508	836616	761906

Notes

Allowable Capacity Reduction

25%	75%
50%	No Unloading

Allowable unit capacity reduction will vary depending upon actual operating conditions. Shading represents expected capacity reduction at given operating conditions. Additional capacity reduction may be realized during low ambient or reduced load situations. Unit microprocessor will increase capacity reduction as operating conditions allow.

^ = Placeholder for voltage code (D or E)

Medium Temperature Models

R-404A Models	Compressor		Condenser		Connections		Receiver (90 % Full)				Unit Length		Approx. Net Weight	
	Part #	Quantity	No. Fans	Dia.	Liquid	Suction	R404A		R407C		In.	M.	Lbs.	Kg.
							Lbs.	Kg.	Lbs.	Kg.				
SSV050BM*^	CHS6553-50Y	1	4	30"	1-3/8	2-1/8	162	73	173	78	159.2	4.04	3692	1675
SSV060BM*^	CHS6563-60Y	1	6	30"	1-3/8	2-1/8	195	89	208	94	212.3	5.39	4527	2053
SSV070BM*^	CSH7553-70Y	1	6	30"	1-3/8	3-1/8	195	89	208	94	212.3	5.39	5120	2322
SSV080BM*^	CHS7563-80Y	1	6	30"	1-5/8	3-1/8	232	105	248	112	212.3	5.39	5313	2410
SSV090BM*^	CSH7573-90Y	1	8	30"	1-5/8	3-1/8	338	153	360	163	265.4	6.74	6076	2756
SSV100BM*^	CSH7583-100Y	1	8	30"	2-1/8	3-1/8	-	-	360	163	265.4	6.74	6098	2766
SSV110BM*^	CHS8553-110Y	1	8	30"	2-1/8	4-1/8	560	254	461	209	265.4	6.74	7360	3338
SSV125BM*^	CHS8563Y-125	1	10	30"	2-1/8	4-1/8	560	254	461	209	318.4	8.09	8064	3658
SSV140BM*^	CHS8573-140Y	1	10	30"	2-1/8	4-1/8	560	254	461	209	318.4	8.09	8336	3781
DSV100BM*^	CHS6553-50Y	2	8	30"	1-3/8	2-1/8	162	73	173	78	265.4	6.74	6434	2918
DSV120BM*^	CHS6563-60Y	2	10	30"	1-3/8	2-1/8	195	89	208	94	318.4	8.09	7366	3341
DSV140BM*^	CSH7553-70Y	2	10	30"	1-3/8	3-1/8	195	89	208	94	318.4	8.09	8532	3870

* = Placeholder for refrigerant type (6 - R-404A, 7 - R-407C)

^ = Placeholder for voltage code (D or E)

Note: Model SSV100BM*^ not compatible with R-404A

High Temperature Models

R-407C Models	Compressor		Condenser		Connections		Receiver (90 % Full)		Unit Length		Approx. Net Weight	
	Part #	Quantity	No. Fans	Dia.	Liquid	Suction	Lbs.	Kg.	In.	M.	Lbs.	Kg.
SSV050BH7^	CHS6553-50Y	1	6	30"	1-3/8	2-1/8	173	78	212.3	5.39	4636	2103
SSV060BH7^	CHS6563-60Y	1	8	30"	1-3/8	2-1/8	248	112	265.4	6.74	5298	2403
SSV070BH7^	CSH7553-70Y	1	8	30"	1-3/8	3-1/8	360	163	265.4	6.74	6091	2763
SSV080BH7^	CHS7563-80Y	1	10	30"	1-5/8	3-1/8	461	209	318.4	8.09	7065	3205
SSV090BH7^	CSH7573-90Y	1	10	30"	1-5/8	3-1/8	360	163	318.4	8.09	7305	3313
SSV100BH7^	CSH7583-100Y	1	12	30"	2-1/8	3-1/8	597	271	371.5	9.44	7984	3621

Dimensions (Inches)

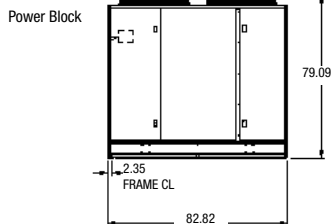
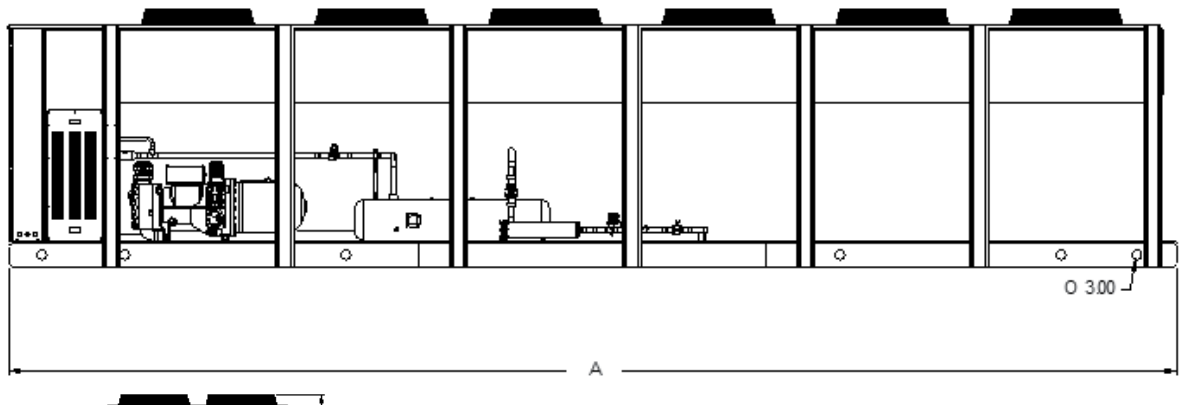

Medium Temperature

Model	Compressor		Power Supply			Compressor		Condenser		Air Defrost	
	Part #	Quantity	Volts	Ph	Hz	RLA	LRA	Qty. of Fans	FLA	MCA	MOPD
SSV050BM*D	CHS6553-50Y	1	460	3	60	86	411	4	14.0	121.5	200
SSV050BM*E	CHS6553-50Y	1	575	3	60	69	329	4	11.2	97.5	150
SSV060BM*D	CHS6563-60Y	1	460	3	60	108	508	6	21.0	156.0	250
SSV060BM*E	CHS6563-60Y	1	575	3	60	87	406	6	16.8	125.6	200
SSV070BM*D	CSH7553-70Y	1	460	3	60	128	485	6	21.0	181.0	300
SSV070BM*E	CSH7553-70Y	1	575	3	60	103	404	6	16.8	145.6	225
SSV080BM*D	CHS7563-80Y	1	460	3	60	144	585	6	21.0	201.0	300
SSV080BM*E	CHS7563-80Y	1	575	3	60	116	433	6	16.8	161.8	250
SSV090BM*D	CSH7573-90Y	1	460	3	60	162	686	8	28.0	230.5	350
SSV090BM*E	CSH7573-90Y	1	575	3	60	130	546	8	22.4	184.9	300
SSV100BM7D	CSH7583-100Y	1	460	3	60	170	796	8	28.0	240.5	400
SSV100BM7E	CSH7583-100Y	1	575	3	60	136	666	8	22.4	192.4	350
SSV110BM*D	CHS8553-110Y	1	460	3	60	185	985	8	28.0	259.3	400
SSV110BM*E	CHS8553-110Y	1	575	3	60	148	642	8	22.4	207.4	300
SSV125BM*D	CHS8563Y-125	1	460	3	60	216	958	10	35.0	305.0	500
SSV125BM*E	CHS8563Y-125	1	575	3	60	173	843	10	28.0	244.3	400
SSV140BM*D	CHS8573-140Y	1	460	3	60	246	1036	10	35.0	342.5	500
SSV140BM*E	CHS8573-140Y	1	575	3	60	197	835	10	28.0	274.3	450
DSV100BM*D	CSH6553-50Y	2	460	3	60	86	411	8	28.0	221.5	300
DSV100BM*E	CSH6553-50Y	2	575	3	60	69	329	8	22.4	177.7	225
DSV120BM*D	CSH6563-60Y	2	460	3	60	108	508	10	35.0	278.0	350
DSV120BM*E	CSH6563-60Y	2	575	3	60	87	406	10	28.0	223.8	300
DSV140BM*D	CSH7553-70Y	2	460	3	60	128	485	10	35.0	323.0	450
DSV140BM*E	CSH7553-70Y	2	575	3	60	103	404	10	28.0	259.8	350

Electric Defrost ‡			
Remote Loads		System MCA†	System MOP††
Evap. Fan Amps	Defrost Heaters Amps		

**CONTACT FACTORY FOR ELECTRICAL RATINGS
FOR ELECTRIC DEFROST SYSTEMS**

Notes

* = Refrigerant (6 - R-404A/507; 7 - R-407C)

† MCA = Minimum Circuit Ampacity

†† MOP = Maximum Overcurrent Protection

‡ Condensing unit data plate ratings will be based on actual system match.

ELECTRICAL DATA

High Temperature

Model	Compressor		Power Supply			Compressor		Condenser		Air Defrost	
	Part #	Quantity	Volts	Ph	Hz	RLA	LRA	Qty. of Fans	FLA	MCA	MOPD
SSV050BH7D	CSH6553-50Y	1	460	3	60	86	411	6	21.0	128.5	200
SSV050BH7E	CSH6553-50Y	1	575	3	60	69	329	6	16.8	103.1	150
SSV060BH7D	CSH6563-60Y	1	460	3	60	108	508	8	28.0	163.0	250
SSV060BH7E	CSH6563-60Y	1	575	3	60	87	406	8	22.4	131.2	200
SSV070BH7D	CSH7553-70Y	1	460	3	60	128	485	8	28.0	188.0	300
SSV070BH7E	CSH7553-70Y	1	575	3	60	103	404	8	22.4	151.2	250
SSV080BH7D	CSH7563-80Y	1	460	3	60	144	585	10	35.0	215.0	350
SSV080BH7E	CSH7563-80Y	1	575	3	60	116	433	10	28.0	173.0	250
SSV090BH7D	CSH7573-90Y	1	460	3	60	162	686	10	35.0	237.5	350
SSV090BH7E	CSH7573-90Y	1	575	3	60	130	546	10	28.0	190.5	300
SSV100BH7D	CHS7853-100Y	1	460	3	60	170	796	12	42.0	254.5	400
SSV100BH7E	CHS7853-100Y	1	575	3	60	136	666	12	33.6	203.6	300

Electric Defrost ‡			
Remote Loads		System MCA†	System MOP††
Evap. Fan Amps	Defrost Heaters Amps		

**CONTACT FACTORY FOR ELECTRICAL RATINGS
FOR ELECTRIC DEFROST SYSTEMS**

Notes

- † MCA = Minimum Circuit Ampacity
- †† MOP = Maximum Overcurrent Protection
- ‡ Condensing unit data plate ratings will be based on actual system match.





2175 West Park Place Blvd. · Stone Mountain, GA 30087
Phone: 800.537.7775 · Fax: 770.465.5900
heatcraftprd.com

BOHN