

LOW PROFILE UNIT COOLERS

Technical Guide
Including models meeting DOE minimum AWEF

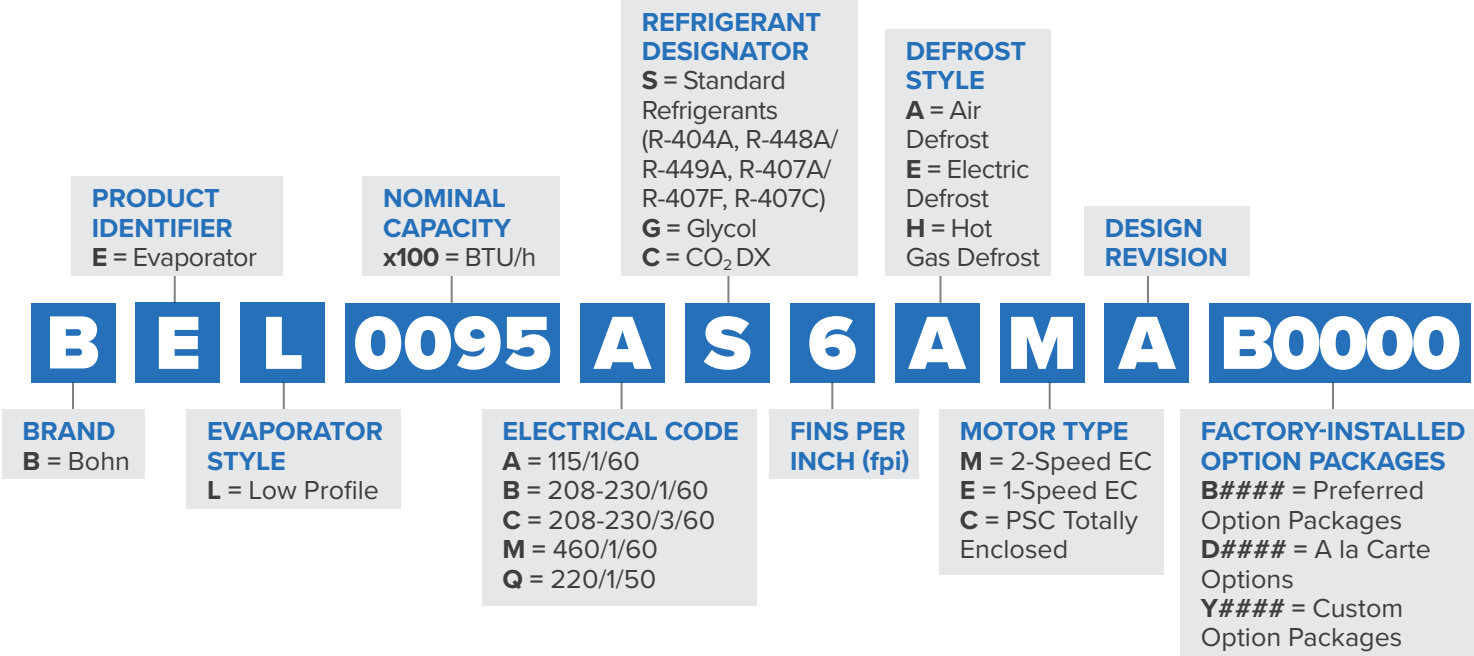


TABLE OF CONTENTS

- 3** Nomenclature
- 3** Preferred Option Packages
- 5** Features & Benefits
- 7** Air Defrost
 - 7** Performance Data
 - 7** Application Capacity: Air Defrost- 60 Hz
 - 8** Application Capacity: Air Defrost- 60 Hz (CO₂ DX)
 - 9** Application Capacity: Air Defrost- 50 Hz (For PSC Motors) †
 - 10** Application Capacity: Air Defrost- 50 Hz (CO₂ DX)
 - 11** Unit Specifications
- 14** Electric Defrost
 - 14** Performance Data
 - 14** Application Capacity: Low Temperature Electric Defrost- 60 Hz
 - 16** Application Capacity: Low Temperature Electric Defrost- 60 Hz (CO₂ DX)
 - 17** Application Capacity: Low Temperature Electric Defrost- 50 Hz (For PSC Motors) †
 - 19** Application Capacity: Low Temperature Electric Defrost- 50 Hz (CO₂ DX)
 - 20** Application Capacity: Medium Temperature Electric Defrost- 60 Hz
 - 22** Application Capacity: Medium Temperature Electric Defrost- 60 Hz (CO₂ DX)
 - 23** Unit Specifications
- Hot Gas Defrost**
 - 27** Performance Data
 - 27** Application Capacity: Low Temperature Hot Gas Defrost- 60 Hz
 - 29** Application Capacity: Low Temperature Hot Gas Defrost- 50 Hz (For PSC Motors) †
 - 31** Application Capacity: Medium Temperature Hot Gas Defrost- 60 Hz
 - 33** Unit Specifications
- 39** Physical Data
- 42** Dimensional Drawings
- DOE Rated AWEF**
 - 43** AWEF
 - 43** Air Defrost 2-Speed EC Motors
 - 44** Electric Defrost 1-Speed EC Motors
 - 45** Electric Defrost 2-Speed EC Motors
 - 46** Hot Gas Defrost 1-Speed EC Motors
 - 47** Hot Gas Defrost 2-Speed EC Motors
- 48** Hot Gas Defrost Reverse Cycle
 - 48** Hot Gas Reverse Cycle Kits
 - 48** Reverse Cycle Piping
- 51** Replacement Parts
 - 51** Motor/Motor Mounts
 - 51** Fan Blade/Fan Guard
 - 51** Cabinet Components
 - 53** Drain Pan Heaters
 - 53** Coil Defrost Heaters
 - 53** Electrical Components
 - 53** Drain Fitting
- 55** Standard Nozzle Selection
 - 55** Air Defrost
 - 56** Electric Defrost
 - 57** Hot Gas Defrost



NOMENCLATURE



PREFERRED OPTION PACKAGES

(HFC Refrigerants)

Package	Description (standard base model features + indicated options below)
B0000	Standard Base
B0100	Beacon II (R-404A/R-448A/R-449A)
B0101	Beacon II (R-407A/R-407C/R-407F)
B0200	intelliGen Refrigeration Controller (R-404A/R-448A/R-449A)
B0201	intelliGen Refrigeration Controller (R-407A/R-407C/R-407F)
B0300	Quick Response Controller (R-404A/R-448A/R-449A)
B0301	Quick Response Controller (R-407A/R-407C/R-407F)
B0403	Mounted Components (TXV, Solenoid Valve, Electronic T'Stat – R-404A)
B0404	Mounted Components (TXV, Solenoid Valve, Electronic T'Stat – R-407A/C/F)
B0405	Mounted Components (TXV, Solenoid Valve, Electronic T'Stat – R-448A/R-449A)

PREFERRED OPTION PACKAGES

(CO₂ DX)

Package	Description (standard base model features + indicated options below)
B0500 Standard Base	Danfoss EEV (120V) with 1/4" MPT Transducer Connection (Pressure Transducer not included)
B0501	Danfoss EEV (120V) with 1/4" MPT Transducer Connection (Pressure Transducer not included) + Filter Drier
B0502	Sporlan EEV (120V) with 1/4" MPT Transducer Connection (Pressure Transducer not included) + Filter Drier
B0503	Danfoss EEV (120V) with Danfoss Pressure Transducer
B0504	Danfoss EEV (120V) with Danfoss Pressure Transducer + Filter Drier
B0505	Danfoss EEV (120V) with CPC Pressure Transducer
B0506	Danfoss EEV (120V) with CPC Pressure Transducer + Filter Drier
B0507	Sporlan EEV (120V) with Microthermo Pressure Transducer + Filter Drier

FEATURES & BENEFITS

CABINET

- Cabinet design features hinged, removable front access panels on each side for easy access to electrical and refrigeration components.
- Molded fan guard and access panels are made of strong, durable, NSF and UL Sanitation rated lightweight and damage-resistant molded plastic material.
- Quick-removal fan guard/motor assembly for easier servicing of air mover parts.
- Sweat connections to reduce potential for leaks.
- Liquid line solenoid wire harness is factory-installed for quick installation.

COIL

- Internally enhanced tubing and fin design for higher efficiency.
- Coil heater slots have been enlarged for easier installation and replacement.
- Hot gas loop on bottom of coil for easier access is standard on hot gas defrost models.
- Fixed defrost termination for electric, adjustable defrost termination for hot gas.

CONTROLS OPTIONS

- **intelliGen™ Refrigeration Controller (iRC)**
 - Factory mounted, tested and calibrated with an electronic expansion valve, pressure transducer, temperature sensors, control board and User Interface. Standard features include Door Sensor, Product Load Input and Alarm Output.
 - Optional Field installable intelliGen™ Webserver Card (iWC) enables local and remote monitoring on any smart phone, tablet or PC.
 - Optional Field installable intelliGen™ Integration Card (iIC) enables connectivity to BACnet and Modbus.
- **Quick Response Controller** units include factory mounted electronic expansion valve, pressure transducer, temperature sensors and control board.
- **Beacon II™** units include factory mounted electronic expansion valve, pressure transducer, temperature sensors and control board.

MOTORS

- Motors plug into wiring harness for easier servicing.
- 2-Speed EC motors standard on Air Defrost models.
- 1-Speed EC motors standard on Electric Defrost & Hot Gas Defrost models.

DRAIN PAN

- Large diameter drain hole (3/4" ID) is located towards the back of the unit.
- Extended drain pan heaters for more uniform defrost throughout the drain pan and additional heat in end compartments.
- Hinged, removable drain pans allow for easy and safe access (3-6 fan units only).

OTHER OPTIONS

- Units available with factory installed mounted components: Expansion Valve, Mechanical Room Thermostat, Solenoid Valve with Dual Voltage Coil.
- Units available with mounted TXV and mounted TXV with solenoid valve.
 - Pre-assembled units come with mounted TXV, liquid line solenoid valve and room thermostat.
 - Available in a master liquid line configuration.
 - Pre-charged units come with mounted TXV, liquid line solenoid valve, room thermostat and quick connect fittings.
- Units available with stainless steel housing and drain pan.
- All units come standard with aluminum fin, copper tube coils. Units available with various coil material / coating options including polyester fin coating, black electrostatic fin coating, copper fins and Bronz-Glow coil coating. Please review our price book for availability.
- Units available with insulated drain pan.

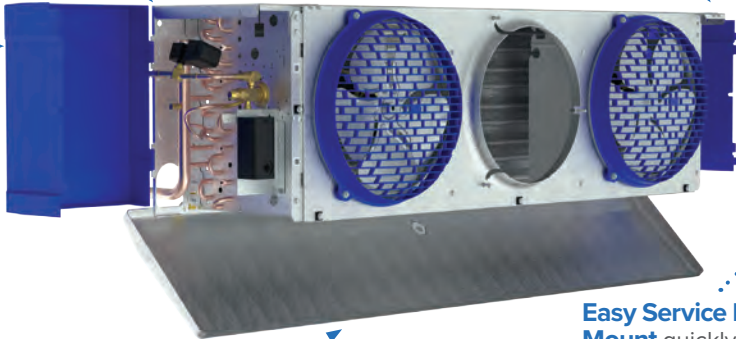
FEATURES & BENEFITS

OUTSTANDING FEATURES

Optional Factory Mounted Components
 Choose from Heatcraft's industry-leading IntelliGen™ Refrigeration Controller, Quick Response Controller, Beacon II Control or traditional mechanical components.

Composite Molded Access Panels have undergone extensive engineering and laboratory testing to ensure they are damage resistant from drops, dents, and bangs.

Hinged & Removeable Access Panels allow for easy access to both refrigeration and electrical end of Low Profile units.



Hinged Drain Pan improves access to service and clean the drain pan and coil. (3-6 fan models only)

Easy Service Motor Mount quickly and easily allows motor to be removed for service or replacement.

Re-Engineered Fan Guards have been redesigned for optimized air circulation and comply to new UL60335 safety standard.

Table 1: Capacity Correction Factors

Electric and Hot Gas Defrost Units				
Saturated Suction Temperature °F	+20	-10	-20	-30
Saturated Suction Temperature °C	-7	-23	-29	-34
Multiply Capacity By	1.15	1.04	1.00	0.90

PERFORMANCE DATA

Application Capacity: Air Defrost- 60 Hz

Please consult AWEF table on page 43 to confirm model meets DOE minimum AWEF

New Model	Legacy Model	R-404A/R-507A		R-448A/R-449A		Fan Data		
		Application Capacity ¹		Application Capacity ¹				
		10°F TD/25°F SST	6°C TD/-4°C SST	10°F TD/25°F SST	6°C TD/-4°C SST	No. of Fans	CFM	m ³ H
		BTUH	Watts	BTUH	Watts			
BEL0045*S6A^A	ADT040	4,000	1,200	4,600	1,300	1	653	1,109
BEL0055*S6A^A	ADT052	5,200	1,500	6,100	1,800	1	610	1,036
BEL0060*S6A^A	ADT065 ADT070	6,500	1,900	7,800	2,300	1	610	1,036
BEL0095*S6A^A	ADT070 ADT090	8,000	2,300	10,000	2,900	2	1,305	2,217
BEL0105*S6A^A	ADT090 ADT104	9,200	2,650	12,500	3,600	2	1,305	2,217
BEL0115*S6A^A	ADT120	11,700	3,370	14,500	4,180	2	1,220	2,073
BEL0125*S6A^A	ADT130	13,000	3,800	15,500	4,500	2	1,220	2,073
BEL0155*S6A^A	ADT140	14,000	4,100	16,800	4,900	3	1,958	3,327
BEL0190*S6A^A	ADT156 ADT180	18,000	5,300	21,200	6,200	3	1,830	3,109
BEL0250*S6A^A	ADT208	20,800	6,100	24,600	7,200	4	2,440	4,146
BEL0295*S6A^A	ADT260	26,000	7,600	30,700	9,000	5	3,050	5,182
BEL0350*S6A^A	ADT312	31,200	9,100	36,800	10,800	6	3,660	6,218
BEL0380*S6A^A	ADT370	37,000	10,800	44,400	13,000	6	3,660	6,218

New Model	Legacy Model	R-407A/R-407F		R-407C		Fan Data		
		Application Capacity ¹		Application Capacity ¹				
		10°F TD/25°F SST	6°C TD/-4°C SST	10°F TD/25°F SST	6°C TD/-4°C SST	No. of Fans	CFM	m ³ H
		BTUH	Watts	BTUH	Watts			
BEL0045*S6A^A	ADT040	4,600	1,300	4,600	1,300	1	653	1,109
BEL0055*S6A^A	ADT052	6,100	1,800	6,100	1,800	1	610	1,036
BEL0060*S6A^A	ADT065 ADT070	7,800	2,300	7,800	2,300	1	610	1,036
BEL0095*S6A^A	ADT070 ADT090	10,000	2,900	10,000	2,900	2	1,305	2,217
BEL0105*S6A^A	ADT090 ADT104	12,500	3,600	12,500	3,600	2	1,305	2,217
BEL0115*S6A^A	ADT120	14,500	4,180	14,500	4,180	2	1,220	2,073
BEL0125*S6A^A	ADT130	15,500	4,500	15,500	4,500	2	1,220	2,073
BEL0155*S6A^A	ADT140	16,800	4,900	16,800	4,900	3	1,958	3,327
BEL0190*S6A^A	ADT156 ADT180	21,200	6,200	21,200	6,200	3	1,830	3,109
BEL0250*S6A^A	ADT208	24,600	7,200	24,600	7,200	4	2,440	4,146
BEL0295*S6A^A	ADT260	30,700	9,000	30,700	9,000	5	3,050	5,182
BEL0350*S6A^A	ADT312	36,800	10,800	36,800	10,800	6	3,660	6,218
BEL0380*S6A^A	ADT370	44,400	13,000	44,400	13,000	6	3,660	6,218

Notes:
¹ = Capacities shown are Application Capacities reflecting nominal operation at 10°F TD. For models within the scope of the DOE AWEF (Annual Walk-in Energy Factor) standard, the Net Capacity is determined by the AHRI 1250 test method. DOE will publish this compliance data at www.regulations.doe.gov
 * = Electrical Code Designator (see Nomenclature details)
 ^ = Motor Code Designator (see Nomenclature details)
 Net Capacity is available upon request

PERFORMANCE DATA

Application Capacity: Air Defrost- 60 Hz

Please consult AWEF table on page 43 to confirm model meets DOE minimum AWEF

New Model	Legacy Model	CO ₂ DX		Fan Data		
		Application Capacity ¹				
		10°F TD/25°F SST	6°C TD/-4°C SST	No. of Fans	CFM	m ³ H
		BTUH	Watts			
BEL0045*C6A^A	ADTY040	4,600	1,348	1	653	1,109
BEL0055*C6A^A	ADTY052	6,100	1,788	1	610	1,036
BEL0060*C6A^A	ADTY065 ADTY070	7,800	2,286	1	610	1,036
BEL0095*C6A^A	ADTY070 ADTY090	10,000	2,931	2	1,305	2,217
BEL0105*C6A^A	ADTY090 ADTY104	12,500	3,663	2	1,305	2,217
BEL0115*C6A^A	ADTY120	14,500	4,250	2	1,220	2,073
BEL0125*C6A^A	ADTY130	15,500	4,543	2	1,220	2,073
BEL0155*C6A^A	ADTY140	16,800	4,924	3	1,958	3,327
BEL0190*C6A^A	ADTY156 ADTY180	21,200	6,213	3	1,830	3,109
BEL0250*C6A^A	ADTY208	24,600	7,210	4	2,440	4,146
BEL0295*C6A^A	ADTY260	30,700	8,997	5	3,050	5,182
BEL0350*C6A^A	ADTY312	36,800	10,785	6	3,660	6,218
BEL0380*C6A^A	ADTY370	44,400	13,012	6	3,660	6,218

Notes:

¹ = Capacities shown are Application Capacities reflecting nominal operation at 10°F TD. For models within the scope of the DOE AWEF (Annual Walk-in Energy Factor) standard, the Net Capacity is determined by the AHRI 1250 test method. DOE will publish this compliance data at www.regulations.doe.gov

* = Electrical Code Designator (see Nomenclature details)

^ = Motor Code Designator (see Nomenclature details)

Net Capacity is available upon request

PERFORMANCE DATA

Application Capacity: Air Defrost- 50 Hz (For PSC Motors)[†]

Please consult AWEF table on page 43 to confirm model meets DOE minimum AWEF

New Model	Legacy Model	R-404A/R-507A		R-448A/R-449A		Fan Data		
		Application Capacity ¹		Application Capacity ¹				
		10°F TD/25°F SST	6°C TD/-4°C SST	10°F TD/25°F SST	6°C TD/-4°C SST	No. of Fans	CFM	m ³ H
		BTUH	Watts	BTUH	Watts			
BEL0045*S6A^A	ADT040	3,800	1,140	4,370	1,235	1	588	999
BEL0055*S6A^A	ADT052	4,940	1,425	5,795	1,710	1	549	933
BEL0060*S6A^A	ADT065 ADT070	6,175	1,805	7,410	2,185	1	549	933
BEL0095*S6A^A	ADT070 ADT090	7,600	2,185	9,500	2,755	2	1,175	1,995
BEL0105*S6A^A	ADT090 ADT104	8,740	2,518	11,875	3,420	2	1,175	1,995
BEL0115*S6A^A	ADT120	11,115	3,202	13,775	3,971	2	1,098	1,866
BEL0125*S6A^A	ADT130	12,350	3,610	14,725	4,275	2	1,098	1,866
BEL0155*S6A^A	ADT140	13,300	3,895	15,960	4,655	3	1,762	2,994
BEL0190*S6A^A	ADT156 ADT180	17,100	5,035	20,140	5,890	3	1,647	2,798
BEL0250*S6A^A	ADT208	19,760	5,795	23,370	6,840	4	2,196	3,731
BEL0295*S6A^A	ADT260	24,700	7,220	29,165	8,550	5	2,745	4,664
BEL0350*S6A^A	ADT312	29,640	8,645	34,960	10,260	6	3,294	5,597
BEL0380*S6A^A	ADT370	35,150	10,260	42,180	12,350	6	3,294	5,597

New Model	Legacy Model	R-407A/R-407F		R-407C		Fan Data		
		Application Capacity ¹		Application Capacity ¹				
		10°F TD/25°F SST	6°C TD/-4°C SST	10°F TD/25°F SST	6°C TD/-4°C SST	No. of Fans	CFM	m ³ H
		BTUH	Watts	BTUH	Watts			
BEL0045*S6A^A	ADT040	4,370	1,235	4,370	1,235	1	588	999
BEL0055*S6A^A	ADT052	5,795	1,710	5,795	1,710	1	549	933
BEL0060*S6A^A	ADT065 ADT070	7,410	2,185	7,410	2,185	1	549	933
BEL0095*S6A^A	ADT070 ADT090	9,500	2,755	9,500	2,755	2	1,175	1,995
BEL0105*S6A^A	ADT090 ADT104	11,875	3,420	11,875	3,420	2	1,175	1,995
BEL0115*S6A^A	ADT120	13,775	3,971	13,775	3,971	2	1,098	1,866
BEL0125*S6A^A	ADT130	14,725	4,275	14,725	4,275	2	1,098	1,866
BEL0155*S6A^A	ADT140	15,960	4,655	15,960	4,655	3	1,762	2,994
BEL0190*S6A^A	ADT156 ADT180	20,140	5,890	20,140	5,890	3	1,647	2,798
BEL0250*S6A^A	ADT208	23,370	6,840	23,370	6,840	4	2,196	3,731
BEL0295*S6A^A	ADT260	29,165	8,550	29,165	8,550	5	2,745	4,664
BEL0350*S6A^A	ADT312	34,960	10,260	34,960	10,260	6	3,294	5,597
BEL0380*S6A^A	ADT370	42,180	12,350	42,180	12,350	6	3,294	5,597

Notes:

¹ = Capacities shown are Application Capacities reflecting nominal operation at 10°F TD. For models within the scope of the DOE AWEF (Annual Walk-in Energy Factor) standard, the Net Capacity is determined by the AHRI 1250 test method. DOE will publish this compliance data at www.regulations.doe.gov

* = Electrical Code Designator (see Nomenclature details)

^ = Motor Code Designator (see Nomenclature details)

Net Capacity is available upon request

[†] = For 1-speed and 2-speed EC motors, use 60 Hz capacity and airflow values. (units with EC motors operating at 50 Hz will not see a reduction in performance due to the electronic control of the motor)

PERFORMANCE DATA

Application Capacity: Air Defrost- 50 Hz (For PSC Motors)[†]

Please consult AWEF table on page 43 to confirm model meets DOE minimum AWEF

New Model	Legacy Model	CO ₂ DX		Fan Data		
		Application Capacity ¹				
		10°F TD/25°F SST	6°C TD/-4°C SST	No. of Fans	CFM	m ³ H
		BTUH	Watts			
BEL0045*C6A^A	ADTY040	4,370	1,281	1	588	999
BEL0055*C6A^A	ADTY052	5,795	1,698	1	549	933
BEL0060*C6A^A	ADTY065 ADTY070	7,410	2,172	1	549	933
BEL0095*C6A^A	ADTY070 ADTY090	9,500	2,784	2	1,175	1,996
BEL0105*C6A^A	ADTY090 ADTY104	11,875	3,480	2	1,175	1,996
BEL0115*C6A^A	ADTY120	13,775	4,037	2	1,098	1,866
BEL0125*C6A^A	ADTY130	14,725	4,315	2	1,098	1,866
BEL0155*C6A^A	ADTY140	15,960	4,677	3	1,762	2,994
BEL0190*C6A^A	ADTY156 ADTY180	20,140	5,902	3	1,647	2,798
BEL0250*C6A^A	ADTY208	23,370	6,849	4	2,196	3,731
BEL0295*C6A^A	ADTY260	29,165	8,547	5	2,745	4,664
BEL0350*C6A^A	ADTY312	34,960	10,246	6	3,294	5,597
BEL0380*C6A^A	ADTY370	42,180	12,362	6	3,294	5,597

Notes:

¹ = Capacities shown are Application Capacities reflecting nominal operation at 10°F TD. For models within the scope of the DOE AWEF (Annual Walk-in Energy Factor) standard, the Net Capacity is determined by the AHRI 1250 test method. DOE will publish this compliance data at www.regulations.doe.gov

* = Electrical Code Designator (see Nomenclature details)

^ = Motor Code Designator (see Nomenclature details)

Net Capacity is available upon request

[†] = For 1-speed and 2-speed EC motors, use 60 Hz capacity and airflow values. (units with EC motors operating at 50 Hz will not see a reduction in performance due to the electronic control of the motor)

SPECIFICATIONS

Air Defrost- 60 Hz

Please consult AWEF table on page 43 to confirm model meets DOE minimum AWEF

2-Speed EC Motor (Totally Enclosed)									
		115/1/60				208-230/1/60			
New Model	HP	Amps	Watts	MCA	MOPD	Amps	Watts	MCA	MOPD
BEL0045*±6AMA	1/20	0.9	55	1.1	20	0.5	55	0.6	15
BEL0055*±6AMA	1/20	0.9	55	1.1	20	0.5	55	0.6	15
BEL0060*±6AMA	1/20	0.9	55	1.1	20	0.5	55	0.6	15
BEL0095*±6AMA	1/20	1.8	110	2.0	20	1.0	110	1.1	15
BEL0105*±6AMA	1/20	1.8	110	2.0	20	1.0	110	1.1	15
BEL0115*±6AMA	1/20	1.8	110	2.0	20	1.0	110	1.1	15
BEL0125*±6AMA	1/20	1.8	110	2.0	20	1.0	110	1.1	15
BEL0155*±6AMA	1/20	2.7	165	2.9	20	1.5	165	1.6	15
BEL0190*±6AMA	1/20	2.7	165	2.9	20	1.5	165	1.6	15
BEL0250*±6AMA	1/20	3.6	220	3.8	20	2.0	220	2.1	15
BEL0295*±6AMA	1/20	4.5	275	4.7	20	2.5	275	2.6	15
BEL0350*±6AMA	1/20	5.4	330	5.6	20	3.0	330	3.1	15
BEL0380*±6AMA	1/20	5.4	330	5.6	20	3.0	330	3.1	15

1-Speed EC Motor (Totally Enclosed)									
		115/1/60				208-230/1/60			
New Model	HP	Amps	Watts	MCA	MOPD	Amps	Watts	MCA	MOPD
BEL0045*±6AEA	1/20	0.9	55	1.1	20	0.5	59	0.6	15
BEL0055*±6AEA	1/20	0.9	55	1.1	20	0.5	59	0.6	15
BEL0060*±6AEA	1/20	0.9	55	1.1	20	0.5	59	0.6	15
BEL0095*±6AEA	1/20	1.8	110	2.0	20	1.0	118	1.1	15
BEL0105*±6AEA	1/20	1.8	110	2.0	20	1.0	118	1.1	15
BEL0115*±6AEA	1/20	1.8	110	2.0	20	1.0	118	1.1	15
BEL0125*±6AEA	1/20	1.8	110	2.0	20	1.0	118	1.1	15
BEL0155*±6AEA	1/20	2.7	165	2.9	20	1.5	177	1.6	15
BEL0190*±6AEA	1/20	2.7	165	2.9	20	1.5	177	1.6	15
BEL0250*±6AEA	1/20	3.6	220	3.8	20	2.0	236	2.1	15
BEL0295*±6AEA	1/20	4.5	275	4.7	20	2.5	295	2.6	15
BEL0350*±6AEA	1/20	5.4	330	5.6	20	3.0	354	3.1	15
BEL0380*±6AEA	1/20	5.4	330	5.6	20	3.0	354	3.1	15

Notes:

* = Electrical Code Designator (see Nomenclature details)

± = Refrigerant Designator (see Nomenclature details)

SPECIFICATIONS

Air Defrost- 60 Hz

Please consult AWEF table on page 43 to confirm model meets DOE minimum AWEF

New Model	HP	PSC Motor (Totally Enclosed)											
		115/1/60				208-230/1/60				460/1/60			
		Amps	Watts	MCA	MOPD	Amps	Watts	MCA	MOPD	Amps	Watts	MCA	MOPD
BEL0045*±6ACA	1/20	1.0	82	1.3	20	0.5	91	0.6	15	0.4	117	0.5	15
BEL0055*±6ACA	1/20	1.0	82	1.3	20	0.5	91	0.6	15	0.4	117	0.5	15
BEL0060*±6ACA	1/20	1.0	82	1.3	20	0.5	91	0.6	15	0.4	117	0.5	15
BEL0095*±6ACA	1/20	2.0	164	2.3	20	1.0	182	1.1	15	0.8	234	0.9	15
BEL0105*±6ACA	1/20	2.0	164	2.3	20	1.0	182	1.1	15	0.8	234	0.9	15
BEL0115*±6ACA	1/20	2.0	164	2.3	20	1.0	182	1.1	15	0.8	234	0.9	15
BEL0125*±6ACA	1/20	2.0	164	2.3	20	1.0	182	1.1	15	0.8	234	0.9	15
BEL0155*±6ACA	1/20	3.0	246	3.3	20	1.5	273	1.6	15	1.2	351	1.3	15
BEL0190*±6ACA	1/20	3.0	246	3.3	20	1.5	273	1.6	15	1.2	351	1.3	15
BEL0250*±6ACA	1/20	4.0	328	4.3	20	2.0	364	2.1	15	1.6	468	1.7	15
BEL0295*±6ACA	1/20	5.0	410	5.3	20	2.5	455	2.6	15	2.0	585	2.1	15
BEL0350*±6ACA	1/20	6.0	492	6.3	20	3.0	546	3.1	15	2.4	702	2.5	15
BEL0380*±6ACA	1/20	6.0	492	6.3	20	3.0	546	3.1	15	2.4	702	2.5	15

Notes:
 * = Electrical Code Designator (see Nomenclature details)
 ± = Refrigerant Designator (see Nomenclature details)

SPECIFICATIONS

Air Defrost- 50 Hz

Please consult AWEF table on page 43 to confirm model meets DOE minimum AWEF

New Model	HP	2-Speed EC Motor (Totally Enclosed)				1-Speed EC Motor (Totally Enclosed)				PSC Motor (Totally Enclosed)			
		220/1/50				220/1/50				220/1/50			
		Amps	Watts	MCA	MOPD	Amps	Watts	MCA	MOPD	Amps	Watts	MCA	MOPD
BEL0045*±6A^A	1/20	0.5	55	0.6	15	0.5	59	0.6	15	0.5	65	0.6	15
BEL0055*±6A^A	1/20	0.5	55	0.6	15	0.5	59	0.6	15	0.5	65	0.6	15
BEL0060*±6A^A	1/20	0.5	55	0.6	15	0.5	59	0.6	15	0.5	65	0.6	15
BEL0095*±6A^A	1/20	1.0	110	1.1	15	1.0	118	1.1	15	1.0	130	1.1	15
BEL0105*±6A^A	1/20	1.0	110	1.1	15	1.0	118	1.1	15	1.0	130	1.1	15
BEL0115*±6A^A	1/20	1.0	110	1.1	15	1.0	118	1.1	15	1.0	130	1.1	15
BEL0125*±6A^A	1/20	1.0	110	1.1	15	1.0	118	1.1	15	1.0	130	1.1	15
BEL0155*±6A^A	1/20	1.5	165	1.6	15	1.5	177	1.6	15	1.5	195	1.6	15
BEL0190*±6A^A	1/20	1.5	165	1.6	15	1.5	177	1.6	15	1.5	195	1.6	15
BEL0250*±6A^A	1/20	2.0	220	2.1	15	2.0	236	2.1	15	2.0	260	2.1	15
BEL0295*±6A^A	1/20	2.5	275	2.6	15	2.5	295	2.6	15	2.5	325	2.6	15
BEL0350*±6A^A	1/20	3.0	330	3.1	15	3.0	354	3.1	15	3.0	390	3.1	15
BEL0380*±6A^A	1/20	3.0	330	3.1	15	3.0	354	3.1	15	3.0	390	3.1	15

Notes:

* = Electrical Code Designator (see Nomenclature details)

^ = Motor Code Designator (see Nomenclature details)

± = Refrigerant Designator (see Nomenclature details)

PERFORMANCE DATA

Application Capacity: Low Temperature Electric Defrost- 60 Hz

Please consult AWEF table on pages 44 & 45 to confirm model meets DOE minimum AWEF

Please refer to Table 1: Capacity Correction Factors (page 6) if using Saturated Suction Temperatures different than listed in the information below

FPI	New Model	Legacy Model	R-404A/R-507A		R-448A/R-449A		Fan Data		
			Application Capacity ¹		Application Capacity ¹				
			10°F TD/-20°F SST	6°C TD/-29°C SST	10°F TD/-20°F SST	6°C TD/-29°C SST	No. of Fans	CFM	m ³ H
			BTUH	Watts	BTUH	Watts			
6	BEL0040*S6E^A	LET035 LET040	3,500	1,000	3,900	1,000	1	685	1,164
6	BEL0045*S6E^A	LET040 LET047	4,700	1,400	5,300	1,600	1	641	1,088
6	BEL0065*S6E^A	LET065	6,500	1,900	7,200	2,100	2	1,371	2,329
6	BEL0080*S6E^A	LET075	7,500	2,200	8,400	2,500	2	1,371	2,329
6	BEL0100*S6E^A	LET090	9,000	2,600	9,900	2,900	2	1,281	2,176
6	BEL0130*S6E^A	LET120	12,000	3,500	13,500	4,000	3	2,056	3,493
6	BEL0155*S6E^A	LET140	14,000	4,100	16,000	4,700	3	1,922	3,265
6	BEL0170*S6E^A	LET160	16,000	4,700	17,900	5,200	4	2,741	4,658
6	BEL0205*S6E^A	LET180	18,000	5,300	20,100	5,900	4	2,562	4,353
6	BEL0240*S6E^A	LET200	20,000	5,900	22,800	6,600	5	3,203	5,441
6	BEL0255*S6E^A	LET240	24,000	7,000	26,900	7,900	6	4,112	6,986
6	BEL0310*S6E^A	LET280	28,000	8,200	31,400	9,200	6	3,843	6,529
4	BEL0045*S4E^A	LLE041	4,100	1,200	4,500	1,300	1	667	1,132
4	BEL0070*S4E^A	LLE068	6,800	2,000	7,400	2,200	2	1,425	2,422
4	BEL0090*S4E^A	LLE080	8,000	2,300	8,800	2,600	2	1,332	2,263
4	BEL0135*S4E^A	LLE102	10,200	3,000	12,800	3,700	3	1,998	3,395
4	BEL0180*S4E^A	LLE136	13,600	4,000	17,300	5,000	4	2,664	4,527
4	BEL0220*S4E^A	LLE170	17,000	5,000	19,500	5,600	5	3,331	5,659
4	BEL0275*S4E^A	LLE204 LLE235	23,500	6,900	25,900	7,600	6	3,997	6,790

Notes:
¹ = Capacities shown are Application Capacities reflecting nominal operation at 10°F TD. For models within the scope of the DOE AWEF (Annual Walk-in Energy Factor) standard, the Net Capacity is determined by the AHRI 1250 test method. DOE will publish this compliance data at www.regulations.doe.gov
 * = Electrical Code Designator (see Nomenclature details)
 ^ = Motor Code Designator (see Nomenclature details)
 Net Capacity is available upon request

PERFORMANCE DATA

Application Capacity: Low Temperature Electric Defrost- 60 Hz

Please consult AWEF table on pages 44 & 45 to confirm model meets DOE minimum AWEF

Please refer to Table 1: Capacity Correction Factors (page 6) if using Saturated Suction Temperatures different than listed in the information below

FPI	New Model	Legacy Model	R-407A/R-407F		R-407C		Fan Data		
			Application Capacity ¹		Application Capacity ¹				
			10°F TD/-20°F SST	6°C TD/-29°C SST	10°F TD/-20°F SST	6°C TD/-29°C SST	No. of Fans	CFM	m ³ H
			BTUH	Watts	BTUH	Watts			
6	BEL0040*S6E^A	LET035 LET040	3,900	1,000	-	-	1	685	1,164
6	BEL0045*S6E^A	LET040 LET047	5,300	1,600	-	-	1	641	1,088
6	BEL0065*S6E^A	LET065	7,200	2,100	-	-	2	1,371	2,329
6	BEL0080*S6E^A	LET075	8,400	2,500	-	-	2	1,371	2,329
6	BEL0100*S6E^A	LET090	9,900	2,900	-	-	2	1,281	2,176
6	BEL0130*S6E^A	LET120	13,500	4,000	-	-	3	2,056	3,493
6	BEL0155*S6E^A	LET140	16,000	4,700	-	-	3	1,922	3,265
6	BEL0170*S6E^A	LET160	17,900	5,200	-	-	4	2,741	4,658
6	BEL0205*S6E^A	LET180	20,100	5,900	-	-	4	2,562	4,353
6	BEL0240*S6E^A	LET200	22,400	6,500	-	-	5	3,203	5,441
6	BEL0255*S6E^A	LET240	26,900	7,900	-	-	6	4,112	6,986
6	BEL0310*S6E^A	LET280	31,400	9,200	-	-	6	3,843	6,529
4	BEL0045*S4E^A	LLE041	4,500	1,300	-	-	1	667	1,132
4	BEL0070*S4E^A	LLE068	7,400	2,200	-	-	2	1,425	2,422
4	BEL0090*S4E^A	LLE080	8,800	2,600	-	-	2	1,332	2,263
4	BEL0135*S4E^A	LLE102	12,100	3,500	-	-	3	1,998	3,395
4	BEL0180*S4E^A	LLE136	16,300	4,700	-	-	4	2,664	4,527
4	BEL0220*S4E^A	LLE170	19,600	5,600	-	-	5	3,331	5,659
4	BEL0275*S4E^A	LLE204 LLE235	25,900	7,600	-	-	6	3,997	6,790

Notes:

¹ = Capacities shown are Application Capacities reflecting nominal operation at 10°F TD. For models within the scope of the DOE AWEF (Annual Walk-in Energy Factor) standard, the Net Capacity is determined by the AHRI 1250 test method. DOE will publish this compliance data at www.regulations.doe.gov

* = Electrical Code Designator (see Nomenclature details)

^ = Motor Code Designator (see Nomenclature details)

Net Capacity is available upon request

PERFORMANCE DATA

Application Capacity: Low Temperature Electric Defrost- 60 Hz

Please consult AWEF table on pages 44 & 45 to confirm model meets DOE minimum AWEF

Please refer to Table 1: Capacity Correction Factors (page 6) if using Saturated Suction Temperatures different than listed in the information below

FPI	New Model	Legacy Model	CO ₂ DX		Fan Data		
			Application Capacity ¹				
			10°F TD/-20°F SST	6°C TD/-29°C SST	No. of Fans	CFM	m ³ H
			BTUH	Watts			
6	BEL0040*C6E^A	LETC035 LETC040	3,900	1,143	1	685	1,164
6	BEL0045*C6E^A	LETC040 LETC047	5,300	1,553	1	641	1,088
6	BEL0065*C6E^A	LETC065	7,200	2,110	2	1,371	2,329
6	BEL0080*C6E^A	LETC075	8,400	2,462	2	1,371	2,329
6	BEL0100*C6E^A	LETC090	9,900	2,901	2	1,281	2,176
6	BEL0130*C6E^A	LETC120	13,500	3,956	3	2,056	3,493
6	BEL0155*C6E^A	LETC140	16,000	4,689	3	1,922	3,265
6	BEL0170*C6E^A	LETC160	17,900	5,246	4	2,741	4,657
6	BEL0205*C6E^A	LETC180	20,100	5,891	4	2,562	4,353
6	BEL0240*C6E^A	LETC200	22,400	6,565	5	3,203	5,441
6	BEL0255*C6E^A	LETC240	26,900	7,884	6	4,112	6,986
6	BEL0310*C6E^A	LETC280	31,400	9,202	6	3,843	6,529
4	BEL0045*C4E^A	LLEC041	4,500	1,319	1	667	1,132
4	BEL0070*C4E^A	LLEC068	7,400	2,169	2	1,425	2,422
4	BEL0090*C4E^A	LLEC080	8,800	2,579	2	1,332	2,263
4	BEL0135*C4E^A	LLEC102	12,100	3,546	3	1,998	3,395
4	BEL0180*C4E^A	LLEC136	16,300	4,777	4	2,664	4,527
4	BEL0220*C4E^A	LLEC170	19,600	5,744	5	3,331	5,659
4	BEL0275*C4E^A	LLEC204 LLEC235	25,900	7,591	6	3,997	6,790

Notes:
¹ = Capacities shown are Application Capacities reflecting nominal operation at 10°F TD. For models within the scope of the DOE AWEF (Annual Walk-in Energy Factor) standard, the Net Capacity is determined by the AHRI 1250 test method. DOE will publish this compliance data at www.regulations.doe.gov
 * = Electrical Code Designator (see Nomenclature details)
 ^ = Motor Code Designator (see Nomenclature details)
 Net Capacity is available upon request

PERFORMANCE DATA

Application Capacity: Low Temperature Electric Defrost- 50 Hz (For PSC Motors)[†]

Please consult AWEF table on pages 44 & 45 to confirm model meets DOE minimum AWEF

Please refer to Table 1: Capacity Correction Factors (page 6) if using Saturated Suction Temperatures different than listed in the information below

FPI	New Model	Legacy Model	R-404A/R-507A		R-448A/R-449A		Fan Data		
			Application Capacity ¹		Application Capacity ¹				
			10°F TD/-20°F SST	6°C TD/-29°C SST	10°F TD/-20°F SST	6°C TD/-29°C SST	No. of Fans	CFM	m ³ H
			BTUH	Watts	BTUH	Watts			
6	BEL0040*S6E^A	LET035 LET040	3,325	950	3,705	950	1	617	1,048
6	BEL0045*S6E^A	LET040 LET047	4,465	1,330	5,035	1,520	1	576	979
6	BEL0065*S6E^A	LET065	6,175	1,805	6,840	1,995	2	1,234	2,096
6	BEL0080*S6E^A	LET075	7,125	2,090	7,980	2,375	2	1,234	2,096
6	BEL0100*S6E^A	LET090	8,550	2,470	9,405	2,755	2	1,153	1,959
6	BEL0130*S6E^A	LET120	11,400	3,325	12,825	3,800	3	1,850	3,144
6	BEL0155*S6E^A	LET140	13,300	3,895	15,200	4,465	3	1,729	2,938
6	BEL0170*S6E^A	LET160	15,200	4,465	17,005	4,940	4	2,467	4,192
6	BEL0205*S6E^A	LET180	17,100	5,035	19,095	5,605	4	2,306	3,918
6	BEL0240*S6E^A	LET200	19,000	5,605	21,660	6,270	5	2,882	4,897
6	BEL0255*S6E^A	LET240	22,800	6,650	25,555	7,505	6	3,701	6,288
6	BEL0310*S6E^A	LET280	26,600	7,790	29,830	8,740	6	2,459	5,876
4	BEL0045*S4E^A	LLE041	3,895	1,140	4,275	1,235	1	600	1,019
4	BEL0070*S4E^A	LLE068	6,460	1,900	7,030	2,090	2	1,283	2,180
4	BEL0090*S4E^A	LLE080	7,600	2,185	8,360	2,470	2	1,199	2,037
4	BEL0135*S4E^A	LLE102	9,690	2,850	12,160	3,515	3	1,799	3,056
4	BEL0180*S4E^A	LLE136	12,920	3,800	16,435	4,750	4	2,398	4,074
4	BEL0220*S4E^A	LLE170	16,150	4,750	18,525	5,320	5	2,998	5,093
4	BEL0275*S4E^A	LLE204 LLE235	22,325	6,555	24,605	7,220	6	3,597	6,111

Notes:

¹ = Capacities shown are Application Capacities reflecting nominal operation at 10°F TD. For models within the scope of the DOE AWEF (Annual Walk-in Energy Factor) standard, the Net Capacity is determined by the AHRI 1250 test method. DOE will publish this compliance data at www.regulations.doe.gov

* = Electrical Code Designator (see Nomenclature details)

^ = Motor Code Designator (see Nomenclature details)

Net Capacity is available upon request

[†] = For 1-speed and 2-speed EC motors, use 60 Hz capacity and airflow values. (units with EC motors operating at 50 Hz will not see a reduction in performance due to the electronic control of the motor)

PERFORMANCE DATA

Application Capacity: Low Temperature Electric Defrost- 50 Hz (For PSC Motors) †

Please consult AWEF table on pages 44 & 45 to confirm model meets DOE minimum AWEF

Please refer to Table 1: Capacity Correction Factors (page 6) if using Saturated Suction Temperatures different than listed in the information below

FPI	New Model	Legacy Model	R-407A/R-407F		R-407C		Fan Data		
			Application Capacity ¹		Application Capacity ¹				
			10°F TD/-20°F SST	6°C TD/-29°C SST	10°F TD/-20°F SST	6°C TD/-29°C SST	No. of Fans	CFM	m ³ H
			BTUH	Watts	BTUH	Watts			
6	BEL0040*S6E^A	LET035 LET040	3,705	950	-	-	1	617	1,048
6	BEL0045*S6E^A	LET040 LET047	5,035	1,520	-	-	1	576	979
6	BEL0065*S6E^A	LET065	6,840	1,995	-	-	2	1,234	2,096
6	BEL0080*S6E^A	LET075	7,980	2,375	-	-	2	1,234	2,096
6	BEL0100*S6E^A	LET090	9,405	2,755	-	-	2	1,153	1,959
6	BEL0130*S6E^A	LET120	12,825	3,800	-	-	3	1,850	3,144
6	BEL0155*S6E^A	LET140	15,200	4,465	-	-	3	1,729	2,938
6	BEL0170*S6E^A	LET160	17,005	4,940	-	-	4	2,467	4,192
6	BEL0205*S6E^A	LET180	19,095	5,605	-	-	4	2,306	3,918
6	BEL0240*S6E^A	LET200	21,280	6,175	-	-	5	2,882	4,897
6	BEL0255*S6E^A	LET240	25,555	7,505	-	-	6	3,701	6,288
6	BEL0310*S6E^A	LET280	29,830	8,740	-	-	6	2,459	5,876
4	BEL0045*S4E^A	LLE041	4,275	1,235	-	-	1	600	1,019
4	BEL0070*S4E^A	LLE068	7,030	2,090	-	-	2	1,283	2,180
4	BEL0090*S4E^A	LLE080	8,360	2,470	-	-	2	1,199	2,037
4	BEL0135*S4E^A	LLE102	11,495	3,325	-	-	3	1,799	3,056
4	BEL0180*S4E^A	LLE136	15,485	4,465	-	-	4	2,398	4,074
4	BEL0220*S4E^A	LLE170	18,620	5,320	-	-	5	2,998	5,093
4	BEL0275*S4E^A	LLE204 LLE235	24,605	7,220	-	-	6	3,597	6,111

Notes:

¹ = Capacities shown are Application Capacities reflecting nominal operation at 10°F TD. For models within the scope of the DOE AWEF (Annual Walk-in Energy Factor) standard, the Net Capacity is determined by the AHRI 1250 test method. DOE will publish this compliance data at www.regulations.doe.gov

* = Electrical Code Designator (see Nomenclature details)

^ = Motor Code Designator (see Nomenclature details)

Net Capacity is available upon request

† = For 1-speed and 2-speed EC motors, use 60 Hz capacity and airflow values. (units with EC motors operating at 50 Hz will not see a reduction in performance due to the electronic control of the motor)

PERFORMANCE DATA

Application Capacity: Low Temperature Electric Defrost- 50 Hz (For PSC Motors)[†]

Please consult AWEF table on pages 44 & 45 to confirm model meets DOE minimum AWEF

Please refer to Table 1: Capacity Correction Factors (page 6) if using Saturated Suction Temperatures different than listed in the information below

FPI	New Model	Legacy Model	CO ₂ DX		Fan Data		
			Application Capacity ¹		No. of Fans	CFM	m ³ H
			10°F TD/-20°F SST	6°C TD/-29°C SST			
			BTUH	Watts			
6	BEL0040*C6E^A	LETC035 LETC040	3,705	1,086	1	617	1,048
6	BEL0045*C6E^A	LETC040 LETC047	5,035	1,476	1	576	979
6	BEL0065*C6E^A	LETC065	6,840	2,005	2	1,234	2,096
6	BEL0080*C6E^A	LETC075	7,980	2,339	2	1,234	2,096
6	BEL0100*C6E^A	LETC090	9,405	2,756	2	1,153	1,959
6	BEL0130*C6E^A	LETC120	12,825	3,759	3	1,850	3,144
6	BEL0155*C6E^A	LETC140	15,200	4,455	3	1,729	2,938
6	BEL0170*C6E^A	LETC160	17,005	4,984	4	2,467	4,192
6	BEL0205*C6E^A	LETC180	19,095	5,596	4	2,306	3,918
6	BEL0240*C6E^A	LETC200	21,280	6,237	5	2,882	4,897
6	BEL0255*C6E^A	LETC240	25,555	7,489	6	3,701	6,288
6	BEL0310*C6E^A	LETC280	29,830	8,742	6	2,459	5,876
4	BEL0045*C4E^A	LLEC041	4,275	1,253	1	600	1,019
4	BEL0070*C4E^A	LLEC068	7,030	2,060	2	1,283	2,180
4	BEL0090*C4E^A	LLEC080	8,360	2,450	2	1,199	2,037
4	BEL0135*C4E^A	LLEC102	11,495	3,369	3	1,799	3,056
4	BEL0180*C4E^A	LLEC136	15,485	4,538	4	2,398	4,074
4	BEL0220*C4E^A	LLEC170	18,620	5,457	5	2,998	5,093
4	BEL0275*C4E^A	LLEC204 LLEC235	24,605	7,211	6	3,597	6,111

Notes:

¹ = Capacities shown are Application Capacities reflecting nominal operation at 10°F TD. For models within the scope of the DOE AWEF (Annual Walk-in Energy Factor) standard, the Net Capacity is determined by the AHRI 1250 test method. DOE will publish this compliance data at www.regulations.doe.gov

* = Electrical Code Designator (see Nomenclature details)

^ = Motor Code Designator (see Nomenclature details)

Net Capacity is available upon request

[†] = For 1-speed and 2-speed EC motors, use 60 Hz capacity and airflow values. (units with EC motors operating at 50 Hz will not see a reduction in performance due to the electronic control of the motor)

PERFORMANCE DATA

Application Capacity: Medium Temperature Electric Defrost- 60 Hz

Please consult AWEF table on pages 44 & 45 to confirm model meets DOE minimum AWEF

Please refer to Table 1: Capacity Correction Factors (page 6) if using Saturated Suction Temperatures different than listed in the information below

FPI	New Model	Legacy Model	R-404A/R-507A		R-448A/R-449A		Fan Data		
			Application Capacity ¹		Application Capacity ¹				
			10°F TD/25°F SST	6°C TD/-4°F SST	10°F TD/25°F SST	6°C TD/-4°F SST	No. of Fans	CFM	m ³ H
			BTUH	Watts	BTUH	Watts			
6	BEL0040*S6E^A	LET035 LET040	4,000	1,200	4,500	1,300	1	685	1,164
6	BEL0045*S6E^A	LET040 LET047	5,400	1,550	6,100	1,750	1	641	1,088
6	BEL0065*S6E^A	LET065	7,450	2,150	8,300	2,400	2	1,371	2,329
6	BEL0080*S6E^A	LET075	8,650	2,500	9,650	2,800	2	1,371	2,329
6	BEL0100*S6E^A	LET090	10,350	3,000	11,400	3,300	2	1,281	2,176
6	BEL0130*S6E^A	LET120	13,800	4,000	15,500	4,500	3	2,056	3,493
6	BEL0155*S6E^A	LET140	16,100	4,650	18,400	5,300	3	1,922	3,265
6	BEL0170*S6E^A	LET160	18,400	5,300	20,600	5,950	4	2,741	4,658
6	BEL0205*S6E^A	LET180	20,700	6,000	23,100	6,650	4	2,562	4,353
6	BEL0240*S6E^A	LET200	23,000	6,650	25,750	7,450	5	3,203	5,441
6	BEL0255*S6E^A	LET240	27,600	7,950	30,950	8,950	6	4,112	6,986
6	BEL0310*S6E^A	LET280	32,200	9,300	36,100	10,400	6	3,843	6,529
4	BEL0045*S4E^A	LLE041	4,700	1,400	5,200	1,500	1	667	1,132
4	BEL0070*S4E^A	LLE068	7,800	2,250	8,500	2,450	2	1,425	2,422
4	BEL0090*S4E^A	LLE080	9,200	2,650	10,100	2,900	2	1,332	2,263
4	BEL0135*S4E^A	LLE102	11,750	3,400	13,050	3,800	3	1,998	3,395
4	BEL0180*S4E^A	LLE136	15,650	4,500	17,650	5,100	4	2,664	4,527
4	BEL0220*S4E^A	LLE170	19,550	5,650	21,850	6,300	5	3,331	5,659
4	BEL0275*S4E^A	LLE204 LLE235	27,000	7,800	29,800	8,600	6	3,997	6,790

Notes:
¹ = Capacities shown are Application Capacities reflecting nominal operation at 10°F TD. For models within the scope of the DOE AWEF (Annual Walk-in Energy Factor) standard, the Net Capacity is determined by the AHRI 1250 test method. DOE will publish this compliance data at www.regulations.doe.gov
 * = Electrical Code Designator (see Nomenclature details)
 ^ = Motor Code Designator (see Nomenclature details)
 Net Capacity is available upon request

PERFORMANCE DATA

Application Capacity: Medium Temperature Electric Defrost- 60 Hz

Please consult AWEF table on pages 44 & 45 to confirm model meets DOE minimum AWEF

Please refer to Table 1: Capacity Correction Factors (page 6) if using Saturated Suction Temperatures different than listed in the information below

FPI	New Model	Legacy Model	R-407A/R-407F		R-407C		Fan Data		
			Application Capacity ¹		Application Capacity ¹				
			10°F TD/25°F SST	6°C TD/-4°F SST	10°F TD/25°F SST	6°C TD/-4°F SST	No. of Fans	CFM	m ³ H
			BTUH	Watts	BTUH	Watts			
6	BEL0040*S6E^A	LET035 LET040	4,500	1,300	-	-	1	685	1,164
6	BEL0045*S6E^A	LET040 LET047	6,100	1,750	-	-	1	641	1,088
6	BEL0065*S6E^A	LET065	8,300	2,400	-	-	2	1,371	2,329
6	BEL0080*S6E^A	LET075	9,650	2,800	-	-	2	1,371	2,329
6	BEL0100*S6E^A	LET090	11,400	3,300	-	-	2	1,281	2,176
6	BEL0130*S6E^A	LET120	15,500	4,500	-	-	3	2,056	3,493
6	BEL0155*S6E^A	LET140	18,400	5,300	-	-	3	1,922	3,265
6	BEL0170*S6E^A	LET160	20,600	5,950	-	-	4	2,741	4,658
6	BEL0205*S6E^A	LET180	23,100	6,650	-	-	4	2,562	4,353
6	BEL0240*S6E^A	LET200	25,750	7,450	-	-	5	3,203	5,441
6	BEL0255*S6E^A	LET240	30,950	8,950	-	-	6	4,112	6,986
6	BEL0310*S6E^A	LET280	36,100	10,400	-	-	6	3,843	6,529
4	BEL0045*S4E^A	LLE041	5,200	1,500	-	-	1	667	1,132
4	BEL0070*S4E^A	LLE068	8,500	2,450	-	-	2	1,425	2,422
4	BEL0090*S4E^A	LLE080	10,100	2,900	-	-	2	1,332	2,263
4	BEL0135*S4E^A	LLE102	13,050	3,800	-	-	3	1,998	3,395
4	BEL0180*S4E^A	LLE136	17,650	5,100	-	-	4	2,664	4,527
4	BEL0220*S4E^A	LLE170	21,850	6,300	-	-	5	3,331	5,659
4	BEL0275*S4E^A	LLE204 LLE235	29,800	8,600	-	-	6	3,997	6,790

Notes:

¹ = Capacities shown are Application Capacities reflecting nominal operation at 10°F TD. For models within the scope of the DOE AWEF (Annual Walk-in Energy Factor) standard, the Net Capacity is determined by the AHRI 1250 test method. DOE will publish this compliance data at www.regulations.doe.gov

* = Electrical Code Designator (see Nomenclature details)

^ = Motor Code Designator (see Nomenclature details)

Net Capacity is available upon request

PERFORMANCE DATA

Application Capacity: Medium Temperature Electric Defrost- 60 Hz

Please consult AWEF table on pages 44 & 45 to confirm model meets DOE minimum AWEF

Please refer to Table 1: Capacity Correction Factors (page 6) if using Saturated Suction Temperatures different than listed in the information below

FPI	New Model	Legacy Model	CO ₂ DX		Fan Data		
			Application Capacity ¹		No. of Fans	CFM	m ³ H
			10°F TD/-20°F SST	6°C TD/-29°C SST			
			BTUH	Watts			
6	BEL0040*C6E^A	LETY035 LETY040	4,500	1,319	1	685	1,164
6	BEL0045*C6E^A	LETY040 LETY047	6,100	1,788	1	641	1,089
6	BEL0065*C6E^A	LETY065	8,300	2,432	2	1,371	2,329
6	BEL0080*C6E^A	LETY075	9,650	2,828	2	1,371	2,329
6	BEL0100*C6E^A	LETY090	11,400	3,341	2	1,281	2,176
6	BEL0130*C6E^A	LETY120	15,500	4,543	3	2,056	3,493
6	BEL0155*C6E^A	LETY140	18,400	5,393	3	1,922	3,265
6	BEL0170*C6E^A	LETY160	20,600	6,037	4	2,741	4,657
6	BEL0205*C6E^A	LETY180	23,100	6,770	4	2,562	4,353
6	BEL0240*C6E^A	LETY200	25,750	7,547	5	3,203	5,442
6	BEL0255*C6E^A	LETY240	30,950	9,071	6	4,112	6,986
6	BEL0310*C6E^A	LETY280	36,100	10,580	6	3,843	6,529
4	BEL0045*C4E^A	NA	5,200	1,524	1	641	1,089
4	BEL0070*C4E^A	NA	8,500	2,491	2	1,425	2,421
4	BEL0090*C4E^A	NA	10,100	2,960	2	1,332	2,263
4	BEL0135*C4E^A	NA	13,050	3,825	3	1,998	3,395
4	BEL0180*C4E^A	NA	17,650	5,173	4	2,664	4,526
4	BEL0220*C4E^A	NA	21,850	6,404	5	3,331	5,659
4	BEL0275*C4E^A	NA	29,800	8,734	6	3,997	6,791

Notes:

¹ = Capacities shown are Application Capacities reflecting nominal operation at 10°F TD. For models within the scope of the DOE AWEF (Annual Walk-in Energy Factor) standard, the Net Capacity is determined by the AHRI 1250 test method. DOE will publish this compliance data at www.regulations.doe.gov

* = Electrical Code Designator (see Nomenclature details)

^ = Motor Code Designator (see Nomenclature details)

Net Capacity is available upon request

SPECIFICATIONS

Electric Defrost- 60 Hz

Please consult AWEF table on pages 44 & 45 to confirm model meets DOE minimum AWEF

FPI	New Model	HP	2-Speed EC Motor (Totally Enclosed)				Defrost Heaters-230V			Defrost Heaters-460V	
			208-230/1/60				Watts	230/1/60	230/3/60	Watts	460/1/60
			Amps	Watts	MCA	MOPD					
6	BEL0040*±6EMA	1/20	0.5	55	0.6	15	1,050	4.6	2.8	900	2.0
6	BEL0045*±6EMA	1/20	0.5	55	0.6	15	1,050	4.6	2.8	900	2.0
6	BEL0065*±6EMA	1/20	1.0	110	1.1	15	2,100	9.1	5.7	1,800	3.9
6	BEL0080*±6EMA	1/20	1.0	110	1.1	15	2,100	9.1	5.7	1,800	3.9
6	BEL0100*±6EMA	1/20	1.0	110	1.1	15	2,100	9.1	5.7	1,800	3.9
6	BEL0130*±6EMA	1/20	1.5	165	1.6	15	3,150	13.7	8.5	2,700	5.9
6	BEL0155*±6EMA	1/20	1.5	165	1.6	15	3,150	13.7	8.5	2,700	5.9
6	BEL0170*±6EMA	1/20	2.0	220	2.1	15	4,200	18.3	11.4	3,600	7.8
6	BEL0205*±6EMA	1/20	2.0	220	2.1	15	4,200	18.3	11.4	3,600	7.8
6	BEL0240*±6EMA	1/20	2.5	275	2.6	15	5,250	22.8	14.2	4,500	9.8
6	BEL0255*±6EMA	1/20	3.0	330	3.1	15	6,300	27.4	17.1	5,400	11.7
6	BEL0310*±6EMA	1/20	3.0	330	3.1	15	6,300	27.4	17.1	5,400	11.7
4	BEL0045*±4EMA	1/20	0.5	55	0.6	15	1,050	4.6	2.8	900	2.0
4	BEL0070*±4EMA	1/20	1.0	110	1.1	15	2,100	9.1	5.7	1,800	3.9
4	BEL0090*±4EMA	1/20	1.0	110	1.1	15	2,100	9.1	5.7	1,800	3.9
4	BEL0135*±4EMA	1/20	1.5	165	1.6	15	3,150	13.7	8.5	2,700	5.9
4	BEL0180*±4EMA	1/20	2.0	220	2.1	15	4,200	18.3	11.4	3,600	7.8
4	BEL0220*±4EMA	1/20	2.5	275	2.6	15	5,250	22.8	14.2	4,500	9.8
4	BEL0275*±4EMA	1/20	3.0	330	3.1	15	6,300	27.4	17.1	5,400	11.7

FPI	New Model	HP	1-Speed EC Motor (Totally Enclosed)				Defrost Heaters-230V			Defrost Heaters-460V	
			208-230/1/60				Watts	230/1/60	230/3/60	Watts	460/1/60
			Amps	Watts	MCA	MOPD					
6	BEL0040*±6EEA	1/20	0.5	59	0.6	15	1,050	4.6	2.8	900	2.0
6	BEL0045*±6EEA	1/20	0.5	59	0.6	15	1,050	4.6	2.8	900	2.0
6	BEL0065*±6EEA	1/20	1.0	118	1.1	15	2,100	9.1	5.7	1,800	3.9
6	BEL0080*±6EEA	1/20	1.0	118	1.1	15	2,100	9.1	5.7	1,800	3.9
6	BEL0100*±6EEA	1/20	1.0	118	1.1	15	2,100	9.1	5.7	1,800	3.9
6	BEL0130*±6EEA	1/20	1.5	177	1.6	15	3,150	13.7	8.5	2,700	5.9
6	BEL0155*±6EEA	1/20	1.5	177	1.6	15	3,150	13.7	8.5	2,700	5.9
6	BEL0170*±6EEA	1/20	2.0	236	2.1	15	4,200	18.3	11.4	3,600	7.8
6	BEL0205*±6EEA	1/20	2.0	236	2.1	15	4,200	18.3	11.4	3,600	7.8
6	BEL0240*±6EEA	1/20	2.5	295	2.6	15	5,250	22.8	14.2	4,500	9.8
6	BEL0255*±6EEA	1/20	3.0	354	3.1	15	6,300	27.4	17.1	5,400	11.7
6	BEL0310*±6EEA	1/20	3.0	354	3.1	15	6,300	27.4	17.1	5,400	11.7
4	BEL0045*±4EEA	1/20	0.5	59	0.6	15	1,050	4.6	2.8	900	2.0
4	BEL0070*±4EEA	1/20	1.0	118	1.1	15	2,100	9.1	5.7	1,800	3.9
4	BEL0090*±4EEA	1/20	1.0	118	1.1	15	2,100	9.1	5.7	1,800	3.9
4	BEL0135*±4EEA	1/20	1.5	177	1.6	15	3,150	13.7	8.5	2,700	5.9
4	BEL0180*±4EEA	1/20	2.0	236	2.1	15	4,200	18.3	11.4	3,600	7.8
4	BEL0220*±4EEA	1/20	2.5	295	2.6	15	5,250	22.8	14.2	4,500	9.8
4	BEL0275*±4EEA	1/20	3.0	354	3.1	15	6,300	27.4	17.1	5,400	11.7

Notes:

* = Electrical Code Designator (see Nomenclature details)

± = Refrigerant Designator (see Nomenclature details)

SPECIFICATIONS

Electric Defrost- 60 Hz

Please consult AWEF table on pages 44 & 45 to confirm model meets DOE minimum AWEF

FPI	New Model	HP	PSC Motor (Totally Enclosed)				Defrost Heaters-230V			Defrost Heaters-460V	
			208-230/1/60				Watts	230/1/60	230/3/60	Watts	460/1/60
			Amps	Watts	MCA	MOPD		Total Amps			Total Amps
6	BEL0040*±6ECA	1/20	0.5	91	0.6	15	1,050	4.6	2.8	900	2.0
6	BEL0045*±6ECA	1/20	0.5	91	0.6	15	1,050	4.6	2.8	900	2.0
6	BEL0065*±6ECA	1/20	1.0	182	1.1	15	2,100	9.1	5.7	1,800	3.9
6	BEL0080*±6ECA	1/20	1.0	182	1.1	15	2,100	9.1	5.7	1,800	3.9
6	BEL0100*±6ECA	1/20	1.0	182	1.1	15	2,100	9.1	5.7	1,800	3.9
6	BEL0130*±6ECA	1/20	1.5	273	1.6	15	3,150	13.7	8.5	2,700	5.9
6	BEL0155*±6ECA	1/20	1.5	273	1.6	15	3,150	13.7	8.5	2,700	5.9
6	BEL0170*±6ECA	1/20	2.0	364	2.1	15	4,200	18.3	11.4	3,600	7.8
6	BEL0205*±6ECA	1/20	2.0	364	2.1	15	4,200	18.3	11.4	3,600	7.8
6	BEL0240*±6ECA	1/20	2.5	455	2.6	15	5,250	22.8	14.2	4,500	9.8
6	BEL0255*±6ECA	1/20	3.0	546	3.1	15	6,300	27.4	17.1	5,400	11.7
6	BEL0310*±6ECA	1/20	3.0	546	3.1	15	6,300	27.4	17.1	5,400	11.7
4	BEL0045*±4ECA	1/20	0.5	91	0.6	15	1,050	4.6	2.8	900	2.0
4	BEL0070*±4ECA	1/20	1.0	182	1.1	15	2,100	9.1	5.7	1,800	3.9
4	BEL0090*±4ECA	1/20	1.0	182	1.1	15	2,100	9.1	5.7	1,800	3.9
4	BEL0135*±4ECA	1/20	1.5	273	1.6	15	3,150	13.7	8.5	2,700	5.9
4	BEL0180*±4ECA	1/20	2.0	364	2.1	15	4,200	18.3	11.4	3,600	7.8
4	BEL0220*±4ECA	1/20	2.5	455	2.6	15	5,250	22.8	14.2	4,500	9.8
4	BEL0275*±4ECA	1/20	3.0	546	3.1	15	6,300	27.4	17.1	5,400	11.7

FPI	New Model	HP	PSC Motor (Totally Enclosed)				Defrost Heaters-230V			Defrost Heaters-460V	
			460/1/60				Watts	230/1/60	230/3/60	Watts	460/1/60
			Amps	Watts	MCA	MOPD		Total Amps			Total Amps
6	BEL0040*±6ECA	1/20	0.4	117	0.5	15	1,050	4.6	2.8	900	2.0
6	BEL0045*±6ECA	1/20	0.4	117	0.5	15	1,050	4.6	2.8	900	2.0
6	BEL0065*±6ECA	1/20	0.8	234	0.9	15	2,100	9.1	5.7	1,800	3.9
6	BEL0080*±6ECA	1/20	0.8	234	0.9	15	2,100	9.1	5.7	1,800	3.9
6	BEL0100*±6ECA	1/20	0.8	234	0.9	15	2,100	9.1	5.7	1,800	3.9
6	BEL0130*±6ECA	1/20	1.2	351	1.3	15	3,150	13.7	8.5	2,700	5.9
6	BEL0155*±6ECA	1/20	1.2	351	1.3	15	3,150	13.7	8.5	2,700	5.9
6	BEL0170*±6ECA	1/20	1.6	468	1.7	15	4,200	18.3	11.4	3,600	7.8
6	BEL0205*±6ECA	1/20	1.6	468	1.7	15	4,200	18.3	11.4	3,600	7.8
6	BEL0240*±6ECA	1/20	2.0	585	2.1	15	5,250	22.8	14.2	4,500	9.8
6	BEL0255*±6ECA	1/20	2.4	702	2.5	15	6,300	27.4	17.1	5,400	11.7
6	BEL0310*±6ECA	1/20	2.4	702	2.5	15	6,300	27.4	17.1	5,400	11.7
4	BEL0045*±4ECA	1/20	0.4	117	0.5	15	1,050	4.6	2.8	900	2.0
4	BEL0070*±4ECA	1/20	0.8	234	0.9	15	2,100	9.1	5.7	1,800	3.9
4	BEL0090*±4ECA	1/20	0.8	234	0.9	15	2,100	9.1	5.7	1,800	3.9
4	BEL0135*±4ECA	1/20	1.2	351	1.3	15	3,150	13.7	8.5	2,700	5.9
4	BEL0180*±4ECA	1/20	1.6	468	1.7	15	4,200	18.3	11.4	3,600	7.8
4	BEL0220*±4ECA	1/20	2.0	585	2.1	15	5,250	22.8	14.2	4,500	9.8
4	BEL0275*±4ECA	1/20	2.4	702	2.5	15	6,300	27.4	17.1	5,400	11.7

Notes:

* = Electrical Code Designator (see Nomenclature details)
 ± = Refrigerant Designator (see Nomenclature details)

SPECIFICATIONS

Electric Defrost- 50 Hz

Please consult AWEF table on pages 44 & 45 to confirm model meets DOE minimum AWEF

FPI	New Model	HP	2-Speed EC Motor (Totally Enclosed)				Defrost Heaters	
			220/1/50				Watts	220/1/50 Total Amps
			Amps	Watts	MCA	MOPD		
6	BEL0040*±6EMA	1/20	0.5	55	0.6	15	960	4.4
6	BEL0045*±6EMA	1/20	0.5	55	0.6	15	960	4.4
6	BEL0065*±6EMA	1/20	1.0	110	1.1	15	1,920	8.7
6	BEL0080*±6EMA	1/20	1.0	110	1.1	15	1,920	8.7
6	BEL0100*±6EMA	1/20	1.0	110	1.1	15	1,920	8.7
6	BEL0130*±6EMA	1/20	1.5	165	1.6	15	2,880	13.1
6	BEL0155*±6EMA	1/20	1.5	165	1.6	15	2,880	13.1
6	BEL0170*±6EMA	1/20	2.0	220	2.1	15	3,845	17.5
6	BEL0205*±6EMA	1/20	2.0	220	2.1	15	3,845	17.5
6	BEL0240*±6EMA	1/20	2.5	275	2.6	15	4,805	21.8
6	BEL0255*±6EMA	1/20	3.0	330	3.1	15	5,765	26.2
6	BEL0310*±6EMA	1/20	3.0	330	3.1	15	5,765	26.2
4	BEL0045*±4EMA	1/20	0.5	55	0.6	15	960	4.4
4	BEL0070*±4EMA	1/20	1.0	110	1.1	15	1,920	8.7
4	BEL0090*±4EMA	1/20	1.0	110	1.1	15	1,920	8.7
4	BEL0135*±4EMA	1/20	1.5	165	1.6	15	2,880	13.1
4	BEL0180*±4EMA	1/20	2.0	220	2.1	15	3,845	17.5
4	BEL0220*±4EMA	1/20	2.5	275	2.6	15	4,805	21.8
4	BEL0275*±4EMA	1/20	3.0	330	3.1	15	5,765	26.2

FPI	New Model	HP	1-Speed EC Motor (Totally Enclosed)				Defrost Heaters	
			220/1/50				Watts	220/1/50 Total Amps
			Amps	Watts	MCA	MOPD		
6	BEL0040*±6EEA	1/20	0.5	59	0.6	15	960	4.4
6	BEL0045*±6EEA	1/20	0.5	59	0.6	15	960	4.4
6	BEL0065*±6EEA	1/20	1.0	118	1.1	15	1,920	8.7
6	BEL0080*±6EEA	1/20	1.0	118	1.1	15	1,920	8.7
6	BEL0100*±6EEA	1/20	1.0	118	1.1	15	1,920	8.7
6	BEL0130*±6EEA	1/20	1.5	177	1.6	15	2,880	13.1
6	BEL0155*±6EEA	1/20	1.5	177	1.6	15	2,880	13.1
6	BEL0170*±6EEA	1/20	2.0	236	2.1	15	3,845	17.5
6	BEL0205*±6EEA	1/20	2.0	236	2.1	15	3,845	17.5
6	BEL0240*±6EEA	1/20	2.5	295	2.6	15	4,805	21.8
6	BEL0255*±6EEA	1/20	3.0	354	3.1	15	5,765	26.2
6	BEL0310*±6EEA	1/20	3.0	354	3.1	15	5,765	26.2
4	BEL0045*±4EEA	1/20	0.5	59	0.6	15	960	4.4
4	BEL0070*±4EEA	1/20	1.0	118	1.1	15	1,920	8.7
4	BEL0090*±4EEA	1/20	1.0	118	1.1	15	1,920	8.7
4	BEL0135*±4EEA	1/20	1.5	177	1.6	15	2,880	13.1
4	BEL0180*±4EEA	1/20	2.0	236	2.1	15	3,845	17.5
4	BEL0220*±4EEA	1/20	2.5	295	2.6	15	4,805	21.8
4	BEL0275*±4EEA	1/20	3.0	354	3.1	15	5,765	26.2

Notes:

* = Electrical Code Designator (see Nomenclature details)

± = Refrigerant Designator (see Nomenclature details)

SPECIFICATIONS

Electric Defrost- 50 Hz

Please consult AWEF table on pages 44 & 45 to confirm model meets DOE minimum AWEF

FPI	New Model	HP	PSC Motor (Totally Enclosed)				Defrost Heaters	
			220/1/50				Watts	220/1/50 Total Amps
			Amps	Watts	MCA	MOPD		
6	BEL0040*±6ECA	1/20	0.5	65	0.6	15	960	4.4
6	BEL0045*±6ECA	1/20	0.5	65	0.6	15	960	4.4
6	BEL0065*±6ECA	1/20	1.0	130	1.1	15	1,920	8.7
6	BEL0080*±6ECA	1/20	1.0	130	1.1	15	1,920	8.7
6	BEL0100*±6ECA	1/20	1.0	130	1.1	15	1,920	8.7
6	BEL0130*±6ECA	1/20	1.5	195	1.6	15	2,880	13.1
6	BEL0155*±6ECA	1/20	1.5	195	1.6	15	2,880	13.1
6	BEL0170*±6ECA	1/20	2.0	260	2.1	15	3,845	17.5
6	BEL0205*±6ECA	1/20	2.0	260	2.1	15	3,845	17.5
6	BEL0240*±6ECA	1/20	2.5	325	2.6	15	4,805	21.8
6	BEL0255*±6ECA	1/20	3.0	390	3.1	15	5,765	26.2
6	BEL0310*±6ECA	1/20	3.0	390	3.1	15	5,765	26.2
4	BEL0045*±4ECA	1/20	0.5	65	0.6	15	960	4.4
4	BEL0070*±4ECA	1/20	1.0	130	1.1	15	1,920	8.7
4	BEL0090*±4ECA	1/20	1.0	130	1.1	15	1,920	8.7
4	BEL0135*±4ECA	1/20	1.5	195	1.6	15	2,880	13.1
4	BEL0180*±4ECA	1/20	2.0	260	2.1	15	3,845	17.5
4	BEL0220*±4ECA	1/20	2.5	325	2.6	15	4,805	21.8
4	BEL0275*±4ECA	1/20	3.0	390	3.1	15	5,765	26.2

Notes:

* = Electrical Code Designator (see Nomenclature details)

± = Refrigerant Designator (see Nomenclature details)

PERFORMANCE DATA

Application Capacity: Low Temperature Hot Gas Defrost- 60 Hz

Please consult AWEF table on pages 46 & 47 to confirm model meets DOE minimum AWEF

Please refer to Table 1: Capacity Correction Factors (page 6) if using Saturated Suction Temperatures different than listed in the information below

FPI	New Model	Legacy Model	R-404A/R-507A		R-448A/R-449A		Fan Data		
			Application Capacity ¹		Application Capacity ¹				
			10°F TD/-20°F SST	6°C TD/-29°C SST	10°F TD/-20°F SST	6°C TD/-29°C SST	No. of Fans	CFM	m ³ H
			BTUH	Watts	BTUH	Watts			
6	BEL0040*S6H^A	HGT035 HGT040	3,500	1,000	3,900	1,000	1	685	1,164
6	BEL0045*S6H^A	HGT040 HGT047	4,700	1,400	5,300	1,600	1	641	1,088
6	BEL0065*S6H^A	HGT065	6,500	1,900	7,200	2,100	2	1,371	2,329
6	BEL0080*S6H^A	HGT075	7,500	2,200	8,400	2,500	2	1,371	2,329
6	BEL0100*S6H^A	HGT090	9,000	2,600	9,900	2,900	2	1,281	2,176
6	BEL0130*S6H^A	HGT120	12,000	3,500	13,500	4,000	3	2,056	3,493
6	BEL0155*S6H^A	HGT140	14,000	4,100	16,000	4,700	3	1,922	3,265
6	BEL0170*S6H^A	HGT160	16,000	4,700	17,900	5,200	4	2,741	4,658
6	BEL0205*S6H^A	HGT180	18,000	5,300	20,100	5,900	4	2,562	4,353
6	BEL0240*S6H^A	HGT200	20,000	5,900	22,800	6,600	5	3,203	5,441
6	BEL0255*S6H^A	HGT240	24,000	7,000	26,900	7,900	6	4,112	6,986
6	BEL0310*S6H^A	HGT280	28,000	8,200	31,400	9,200	6	3,843	6,529
4	BEL0045*S4H^A	HGT041	4,100	1,200	4,500	1,300	1	667	1,132
4	BEL0070*S4H^A	HGT068	6,800	2,000	7,400	2,200	2	1,425	2,422
4	BEL0090*S4H^A	HGT080	8,000	2,300	8,800	2,600	2	1,332	2,263
4	BEL0135*S4H^A	HGT102	10,200	3,000	12,800	3,700	3	1,998	3,395
4	BEL0180*S4H^A	HGT136	13,600	4,000	17,300	5,000	4	2,664	4,527
4	BEL0220*S4H^A	HGT170	17,000	5,000	19,500	5,600	5	3,331	5,659
4	BEL0275*S4H^A	HGT204 HGT235	23,500	6,900	25,900	7,600	6	3,997	6,790

Notes:

¹ = Capacities shown are Application Capacities reflecting nominal operation at 10°F TD. For models within the scope of the DOE AWEF (Annual Walk-in Energy Factor) standard, the Net Capacity is determined by the AHRI 1250 test method. DOE will publish this compliance data at www.regulations.doe.gov

* = Electrical Code Designator (see Nomenclature details)

^ = Motor Code Designator (see Nomenclature details)

Net Capacity is available upon request

PERFORMANCE DATA

Application Capacity: Low Temperature Hot Gas Defrost- 60 Hz

Please consult AWEF table on pages 46 & 47 to confirm model meets DOE minimum AWEF

Please refer to Table 1: Capacity Correction Factors (page 6) if using Saturated Suction Temperatures different than listed in the information below

FPI	New Model	Legacy Model	R-407A/R-407F		R-407C		Fan Data		
			Application Capacity ¹		Application Capacity ¹				
			10°F TD/-20°F SST	6°C TD/-29°C SST	10°F TD/-20°F SST	6°C TD/-29°C SST	No. of Fans	CFM	m ³ H
			BTUH	Watts	BTUH	Watts			
6	BEL0040*S6H^A	HGT035 HGT040	3,900	1,000	-	-	1	685	1,164
6	BEL0045*S6H^A	HGT040 HGT047	5,300	1,600	-	-	1	641	1,088
6	BEL0065*S6H^A	HGT065	7,200	2,100	-	-	2	1,371	2,329
6	BEL0080*S6H^A	HGT075	8,400	2,500	-	-	2	1,371	2,329
6	BEL0100*S6H^A	HGT090	9,900	2,900	-	-	2	1,281	2,176
6	BEL0130*S6H^A	HGT120	13,500	4,000	-	-	3	2,056	3,493
6	BEL0155*S6H^A	HGT140	16,000	4,700	-	-	3	1,922	3,265
6	BEL0170*S6H^A	HGT160	17,900	5,200	-	-	4	2,741	4,658
6	BEL0205*S6H^A	HGT180	20,100	5,900	-	-	4	2,562	4,353
6	BEL0240*S6H^A	HGT200	22,400	6,500	-	-	5	3,203	5,441
6	BEL0255*S6H^A	HGT240	26,900	7,900	-	-	6	4,112	6,986
6	BEL0310*S6H^A	HGT280	31,400	9,200	-	-	6	3,843	6,529
4	BEL0045*S4H^A	HGT041	4,500	1,300	-	-	1	667	1,132
4	BEL0070*S4H^A	HGT068	7,400	2,200	-	-	2	1,425	2,422
4	BEL0090*S4H^A	HGT080	8,800	2,600	-	-	2	1,332	2,263
4	BEL0135*S4H^A	HGT102	12,100	3,500	-	-	3	1,998	3,395
4	BEL0180*S4H^A	HGT136	16,300	4,700	-	-	4	2,664	4,527
4	BEL0220*S4H^A	HGT170	19,600	5,500	-	-	5	3,331	5,659
4	BEL0275*S4H^A	HGT204 HGT235	25,900	7,600	-	-	6	3,997	6,790

Notes:

¹ = Capacities shown are Application Capacities reflecting nominal operation at 10°F TD. For models within the scope of the DOE AWEF (Annual Walk-in Energy Factor) standard, the Net Capacity is determined by the AHRI 1250 test method. DOE will publish this compliance data at www.regulations.doe.gov

* = Electrical Code Designator (see Nomenclature details)

^ = Motor Code Designator (see Nomenclature details)

Net Capacity is available upon request

PERFORMANCE DATA

Application Capacity: Low Temperature Hot Gas Defrost- 50 Hz (For PSC Motors)[†]

Please consult AWEF table on pages 46 & 47 to confirm model meets DOE minimum AWEF

Please refer to Table 1: Capacity Correction Factors (page 6) if using Saturated Suction Temperatures different than listed in the information below

FPI	New Model	Legacy Model	R-404A/R-507A		R-448A/R-449A		Fan Data		
			Application Capacity ¹		Application Capacity ¹				
			10°F TD/-20°F SST	6°C TD/-29°C SST	10°F TD/-20°F SST	6°C TD/-29°C SST	No. of Fans	CFM	m ³ H
			BTUH	Watts	BTUH	Watts			
6	BEL0040*S6H^A	HGT035 HGT040	3,325	950	3,705	950	1	617	1,048
6	BEL0045*S6H^A	HGT040 HGT047	4,465	1,330	5,035	1,520	1	576	979
6	BEL0065*S6H^A	HGT065	6,175	1,805	6,840	1,995	2	1,234	2,096
6	BEL0080*S6H^A	HGT075	7,125	2,090	7,980	2,375	2	1,234	2,096
6	BEL0100*S6H^A	HGT090	8,550	2,470	9,405	2,755	2	1,153	1,959
6	BEL0130*S6H^A	HGT120	11,400	3,325	12,825	3,800	3	1,850	3,144
6	BEL0155*S6H^A	HGT140	13,300	3,895	15,200	4,465	3	1,729	2,938
6	BEL0170*S6H^A	HGT160	15,200	4,465	17,005	4,940	4	2,467	4,192
6	BEL0205*S6H^A	HGT180	17,100	5,035	19,095	5,605	4	2,306	3,918
6	BEL0240*S6H^A	HGT200	19,000	5,605	21,660	6,270	5	2,882	4,897
6	BEL0255*S6H^A	HGT240	22,800	6,650	25,555	7,505	6	3,701	6,288
6	BEL0310*S6H^A	HGT280	26,600	7,790	29,830	8,740	6	2,459	5,876
4	BEL0045*S4H^A	HGT041	3,895	1,140	4,275	1,235	1	600	1,019
4	BEL0070*S4H^A	HGT068	6,460	1,900	7,030	2,090	2	1,283	2,180
4	BEL0090*S4H^A	HGT080	7,600	2,185	8,360	2,470	2	1,199	2,037
4	BEL0135*S4H^A	HGT102	9,690	2,850	12,160	3,515	3	1,799	3,056
4	BEL0180*S4H^A	HGT136	12,920	3,800	16,435	4,750	4	2,398	4,074
4	BEL0220*S4H^A	HGT170	16,150	4,750	18,525	5,320	5	2,998	5,093
4	BEL0275*S4H^A	HGT204 HGT235	22,325	6,555	24,605	7,220	6	3,597	6,111

Notes:

¹ = Capacities shown are Application Capacities reflecting nominal operation at 10°F TD. For models within the scope of the DOE AWEF (Annual Walk-in Energy Factor) standard, the Net Capacity is determined by the AHRI 1250 test method. DOE will publish this compliance data at www.regulations.doe.gov

* = Electrical Code Designator (see Nomenclature details)

^ = Motor Code Designator (see Nomenclature details)

Net Capacity is available upon request

[†] = For 1-speed and 2-speed EC motors, use 60 Hz capacity and airflow values. (units with EC motors operating at 50 Hz will not see a reduction in performance due to the electronic control of the motor)

PERFORMANCE DATA

Application Capacity: Low Temperature Hot Gas Defrost- 50 Hz (For PSC Motors)[†]

Please consult AWEF table on pages 46 & 47 to confirm model meets DOE minimum AWEF

Please refer to Table 1: Capacity Correction Factors (page 6) if using Saturated Suction Temperatures different than listed in the information below

FPI	New Model	Legacy Model	R-407A/R-407F		R-407C		Fan Data		
			Application Capacity ¹		Application Capacity ¹				
			10°F TD/-20°F SST	6°C TD/-29°C SST	10°F TD/-20°F SST	6°C TD/-29°C SST	No. of Fans	CFM	m ³ H
			BTUH	Watts	BTUH	Watts			
6	BEL0040*S6H^A	HGT035 HGT040	3,705	950	-	-	1	617	1,048
6	BEL0045*S6H^A	HGT040 HGT047	5,035	1,520	-	-	1	576	979
6	BEL0065*S6H^A	HGT065	6,840	1,995	-	-	2	1,234	2,096
6	BEL0080*S6H^A	HGT075	7,980	2,375	-	-	2	1,234	2,096
6	BEL0100*S6H^A	HGT090	9,405	2,755	-	-	2	1,153	1,959
6	BEL0130*S6H^A	HGT120	12,825	3,800	-	-	3	1,850	3,144
6	BEL0155*S6H^A	HGT140	15,200	4,465	-	-	3	1,729	2,938
6	BEL0170*S6H^A	HGT160	17,005	4,940	-	-	4	2,467	4,192
6	BEL0205*S6H^A	HGT180	19,095	5,605	-	-	4	2,306	3,918
6	BEL0240*S6H^A	HGT200	21,280	6,175	-	-	5	2,882	4,897
6	BEL0255*S6H^A	HGT240	25,555	7,505	-	-	6	3,701	6,288
6	BEL0310*S6H^A	HGT280	29,830	8,740	-	-	6	2,459	5,876
4	BEL0045*S4H^A	HGT041	4,275	1,235	-	-	1	600	1,019
4	BEL0070*S4H^A	HGT068	7,030	2,090	-	-	2	1,283	2,180
4	BEL0090*S4H^A	HGT080	8,360	2,470	-	-	2	1,199	2,037
4	BEL0135*S4H^A	HGT102	11,495	3,325	-	-	3	1,799	3,056
4	BEL0180*S4H^A	HGT136	15,485	4,465	-	-	4	2,398	4,074
4	BEL0220*S4H^A	HGT170	18,620	5,225	-	-	5	2,998	5,093
4	BEL0275*S4H^A	HGT204 HGT235	24,605	7,220	-	-	6	3,597	6,111

Notes:

¹ = Capacities shown are Application Capacities reflecting nominal operation at 10°F TD. For models within the scope of the DOE AWEF (Annual Walk-in Energy Factor) standard, the Net Capacity is determined by the AHRI 1250 test method. DOE will publish this compliance data at www.regulations.doe.gov

* = Electrical Code Designator (see Nomenclature details)

^ = Motor Code Designator (see Nomenclature details)

Net Capacity is available upon request

[†] = For 1-speed and 2-speed EC motors, use 60 Hz capacity and airflow values. (units with EC motors operating at 50 Hz will not see a reduction in performance due to the electronic control of the motor)

PERFORMANCE DATA

Application Capacity: Medium Temperature Hot Gas Defrost- 60 Hz

Please consult AWEF table on pages 46 & 47 to confirm model meets DOE minimum AWEF

Please refer to Table 1: Capacity Correction Factors (page 6) if using Saturated Suction Temperatures different than listed in the information below

FPI	New Model	Legacy Model	R-404A/R-507A		R-448A/R-449A		Fan Data		
			Application Capacity ¹		Application Capacity ¹				
			10°F TD/25°F SST	6°C TD/-4°F SST	10°F TD/25°F SST	6°C TD/-4°F SST	No. of Fans	CFM	m ³ H
			BTUH	Watts	BTUH	Watts			
6	BEL0040*S6H^A	HGT035 HGT040	4,000	1,200	4,500	1,300	1	685	1,164
6	BEL0045*S6H^A	HGT040 HGT047	5,400	1,550	6,100	1,750	1	641	1,088
6	BEL0065*S6H^A	HGT065	7,450	2,150	8,300	2,400	2	1,371	2,329
6	BEL0080*S6H^A	HGT075	8,650	2,500	9,650	2,800	2	1,371	2,329
6	BEL0100*S6H^A	HGT090	10,350	3,000	11,400	3,300	2	1,281	2,176
6	BEL0130*S6H^A	HGT120	13,800	4,000	15,500	4,500	3	2,056	3,493
6	BEL0155*S6H^A	HGT140	16,100	4,650	18,400	5,300	3	1,922	3,265
6	BEL0170*S6H^A	HGT160	18,400	5,300	20,600	5,950	4	2,741	4,658
6	BEL0205*S6H^A	HGT180	20,700	6,000	23,100	6,650	4	2,562	4,353
6	BEL0240*S6H^A	HGT200	23,000	6,650	25,750	7,450	5	3,203	5,441
6	BEL0255*S6H^A	HGT240	27,600	7,950	30,950	8,950	6	4,112	6,986
6	BEL0310*S6H^A	HGT280	32,200	9,300	36,100	10,400	6	3,843	6,529
4	BEL0045*S4H^A	HGT041	4,700	1,400	5,200	1,500	1	667	1,132
4	BEL0070*S4H^A	HGT068	7,800	2,250	8,500	2,450	2	1,425	2,422
4	BEL0090*S4H^A	HGT080	9,200	2,650	10,100	2,900	2	1,332	2,263
4	BEL0135*S4H^A	HGT102	11,750	3,400	13,050	3,800	3	1,998	3,395
4	BEL0180*S4H^A	HGT136	15,650	4,500	17,650	5,100	4	2,664	4,527
4	BEL0220*S4H^A	HGT170	19,550	5,650	21,850	6,300	5	3,331	5,659
4	BEL0275*S4H^A	HGT204 HGT235	27,000	7,800	29,800	8,600	6	3,997	6,790

Notes:

¹ = Capacities shown are Application Capacities reflecting nominal operation at 10°F TD. For models within the scope of the DOE AWEF (Annual Walk-in Energy Factor) standard, the Net Capacity is determined by the AHRI 1250 test method. DOE will publish this compliance data at www.regulations.doe.gov

* = Electrical Code Designator (see Nomenclature details)

^ = Motor Code Designator (see Nomenclature details)

Net Capacity is available upon request

PERFORMANCE DATA

Application Capacity: Medium Temperature Hot Gas Defrost- 60 Hz

Please consult AWEF table on pages 46 & 47 to confirm model meets DOE minimum AWEF

Please refer to Table 1: Capacity Correction Factors (page 6) if using Saturated Suction Temperatures different than listed in the information below

FPI	New Model	Legacy Model	R-407A/R-407F		R-407C		Fan Data		
			Application Capacity ¹		Application Capacity ¹				
			10°F TD/25°F SST	6°C TD/-4°F SST	10°F TD/25°F SST	6°C TD/-4°F SST	No. of Fans	CFM	m ³ H
			BTUH	Watts	BTUH	Watts			
6	BEL0040*S6H^A	HGT035 HGT040	4,500	1,300	-	-	1	685	1,164
6	BEL0045*S6H^A	HGT040 HGT047	6,100	1,750	-	-	1	641	1,088
6	BEL0065*S6H^A	HGT065	8,300	2,400	-	-	2	1,371	2,329
6	BEL0080*S6H^A	HGT075	9,650	2,800	-	-	2	1,371	2,329
6	BEL0100*S6H^A	HGT090	11,400	3,300	-	-	2	1,281	2,176
6	BEL0130*S6H^A	HGT120	15,500	4,500	-	-	3	2,056	3,493
6	BEL0155*S6H^A	HGT140	18,400	5,300	-	-	3	1,922	3,265
6	BEL0170*S6H^A	HGT160	20,600	5,950	-	-	4	2,741	4,658
6	BEL0205*S6H^A	HGT180	23,100	6,650	-	-	4	2,562	4,353
6	BEL0240*S6H^A	HGT200	25,750	7,450	-	-	5	3,203	5,441
6	BEL0255*S6H^A	HGT240	30,950	8,950	-	-	6	4,112	6,986
6	BEL0310*S6H^A	HGT280	36,100	10,400	-	-	6	3,843	6,529
4	BEL0045*S4H^A	HGT041	5,200	1,500	-	-	1	667	1,132
4	BEL0070*S4H^A	HGT068	8,500	2,450	-	-	2	1,425	2,422
4	BEL0090*S4H^A	HGT080	10,100	2,900	-	-	2	1,332	2,263
4	BEL0135*S4H^A	HGT102	13,050	3,800	-	-	3	1,998	3,395
4	BEL0180*S4H^A	HGT136	17,650	5,100	-	-	4	2,664	4,527
4	BEL0220*S4H^A	HGT170	21,850	6,300	-	-	5	3,331	5,659
4	BEL0275*S4H^A	HGT204 HGT235	29,800	8,600	-	-	6	3,997	6,790

Notes:
¹ = Capacities shown are Application Capacities reflecting nominal operation at 10°F TD. For models within the scope of the DOE AWEF (Annual Walk-in Energy Factor) standard, the Net Capacity is determined by the AHRI 1250 test method. DOE will publish this compliance data at www.regulations.doe.gov
 * = Electrical Code Designator (see Nomenclature details)
 ^ = Motor Code Designator (see Nomenclature details)
 Net Capacity is available upon request

SPECIFICATIONS

Hot Gas Defrost- 60 Hz

Please consult AWEF table on pages 46 & 47 to confirm model meets DOE minimum AWEF

FPI	New Model	HP	2-Speed EC Motor (Totally Enclosed)				Drain Pan Heaters			
			115/1/60				Watts	115/1/60	230/1/60	460/1/60
			Amps	Watts	MCA	MOPD		Total Amps		
6	BEL0040*S6HMA	1/20	0.9	55	1.1	20	150	1.3	0.7	0.3
6	BEL0045*S6HMA	1/20	0.9	55	1.1	20	150	1.3	0.7	0.3
6	BEL0065*S6HMA	1/20	1.8	110	2.0	20	300	2.6	1.3	0.7
6	BEL0080*S6HMA	1/20	1.8	110	2.0	20	300	2.6	1.3	0.7
6	BEL0100*S6HMA	1/20	1.8	110	2.0	20	300	2.6	1.3	0.7
6	BEL0130*S6HMA	1/20	2.7	165	2.9	20	450	3.9	2.0	1.0
6	BEL0155*S6HMA	1/20	2.7	165	2.9	20	450	3.9	2.0	1.0
6	BEL0170*S6HMA	1/20	3.6	220	3.8	20	600	5.2	2.6	1.3
6	BEL0205*S6HMA	1/20	3.6	220	3.8	20	600	5.2	2.6	1.3
6	BEL0240*S6HMA	1/20	4.5	275	4.7	20	750	6.5	3.3	1.6
6	BEL0255*S6HMA	1/20	5.4	330	5.6	20	900	7.8	3.9	2.0
6	BEL0310*S6HMA	1/20	5.4	330	5.6	20	900	7.8	3.9	2.0
4	BEL0045*S4HMA	1/20	0.9	55	1.1	20	150	1.3	0.7	0.3
4	BEL0070*S4HMA	1/20	1.8	110	2.0	20	300	2.6	1.3	0.7
4	BEL0090*S4HMA	1/20	1.8	110	2.0	20	300	2.6	1.3	0.7
4	BEL0135*S4HMA	1/20	2.7	165	2.9	20	450	3.9	2.0	1.0
4	BEL0180*S4HMA	1/20	3.6	220	3.8	20	600	5.2	2.6	1.3
4	BEL0220*S4HMA	1/20	4.5	275	4.7	20	750	6.5	3.3	1.6
4	BEL0275*S4HMA	1/20	5.4	330	5.6	20	900	7.8	3.9	2.0

FPI	New Model	HP	2-Speed EC Motor (Totally Enclosed)				Drain Pan Heaters			
			208-230/1/60				Watts	115/1/60	230/1/60	460/1/60
			Amps	Watts	MCA	MOPD		Total Amps		
6	BEL0040*S6HMA	1/20	0.5	55	0.6	15	150	1.3	0.7	0.3
6	BEL0045*S6HMA	1/20	0.5	55	0.6	15	150	1.3	0.7	0.3
6	BEL0065*S6HMA	1/20	1.0	110	1.1	15	300	2.6	1.3	0.7
6	BEL0080*S6HMA	1/20	1.0	110	1.1	15	300	2.6	1.3	0.7
6	BEL0100*S6HMA	1/20	1.0	110	1.1	15	300	2.6	1.3	0.7
6	BEL0130*S6HMA	1/20	1.4	165	1.6	15	450	3.9	2.0	1.0
6	BEL0155*S6HMA	1/20	1.4	165	1.6	15	450	3.9	2.0	1.0
6	BEL0170*S6HMA	1/20	1.9	220	2.1	15	600	5.2	2.6	1.3
6	BEL0205*S6HMA	1/20	1.9	220	2.1	15	600	5.2	2.6	1.3
6	BEL0240*S6HMA	1/20	2.4	275	2.6	15	750	6.5	3.3	1.6
6	BEL0255*S6HMA	1/20	2.9	330	3.1	15	900	7.8	3.9	2.0
6	BEL0310*S6HMA	1/20	2.9	330	3.1	15	900	7.8	3.9	2.0
4	BEL0045*S4HMA	1/20	0.5	55	0.6	15	150	1.3	0.7	0.3
4	BEL0070*S4HMA	1/20	1.0	110	1.1	15	300	2.6	1.3	0.7
4	BEL0090*S4HMA	1/20	1.0	110	1.1	15	300	2.6	1.3	0.7
4	BEL0135*S4HMA	1/20	1.4	165	1.6	15	450	3.9	2.0	1.0
4	BEL0180*S4HMA	1/20	1.9	220	2.1	15	600	5.2	2.6	1.3
4	BEL0220*S4HMA	1/20	2.4	275	2.6	15	750	6.5	3.3	1.6
4	BEL0275*S4HMA	1/20	2.9	330	3.1	15	900	7.8	3.9	2.0

Notes:

* = Electrical Code Designator (see Nomenclature details)

SPECIFICATIONS

Hot Gas Defrost- 60 Hz

Please consult AWEF table on pages 46 & 47 to confirm model meets DOE minimum AWEF

FPI	New Model	HP	1-Speed EC Motor (Totally Enclosed)				Drain Pan Heaters			
			115/1/60				Watts	115/1/60	230/1/60	460/1/60
			Amps	Watts	MCA	MOPD		Total Amps		
6	BEL0040*S6HEA	1/20	0.9	55	1.1	20	150	1.3	0.7	0.3
6	BEL0045*S6HEA	1/20	0.9	55	1.1	20	150	1.3	0.7	0.3
6	BEL0065*S6HEA	1/20	1.8	110	2.0	20	300	2.6	1.3	0.7
6	BEL0080*S6HEA	1/20	1.8	110	2.0	20	300	2.6	1.3	0.7
6	BEL0100*S6HEA	1/20	1.8	110	2.0	20	300	2.6	1.3	0.7
6	BEL0130*S6HEA	1/20	2.7	165	2.9	20	450	3.9	2.0	1.0
6	BEL0155*S6HEA	1/20	2.7	165	2.9	20	450	3.9	2.0	1.0
6	BEL0170*S6HEA	1/20	3.6	220	3.8	20	600	5.2	2.6	1.3
6	BEL0205*S6HEA	1/20	3.6	220	3.8	20	600	5.2	2.6	1.3
6	BEL0240*S6HEA	1/20	4.5	270	4.7	20	750	6.5	3.3	1.6
6	BEL0255*S6HEA	1/20	5.4	330	5.6	20	900	7.8	3.9	2.0
6	BEL0310*S6HEA	1/20	5.4	330	5.6	20	900	7.8	3.9	2.0
4	BEL0045*S4HEA	1/20	0.9	55	1.1	20	150	1.3	0.7	0.3
4	BEL0070*S4HEA	1/20	1.8	110	2.0	20	300	2.6	1.3	0.7
4	BEL0090*S4HEA	1/20	1.8	110	2.0	20	300	2.6	1.3	0.7
4	BEL0135*S4HEA	1/20	2.7	165	2.9	20	450	3.9	2.0	1.0
4	BEL0180*S4HEA	1/20	3.6	220	3.8	20	600	5.2	2.6	1.3
4	BEL0220*S4HEA	1/20	4.5	275	4.7	20	750	6.5	3.3	1.6
4	BEL0275*S4HEA	1/20	5.4	330	5.6	20	900	7.8	3.9	2.0

FPI	New Model	HP	1-Speed EC Motor (Totally Enclosed)				Drain Pan Heaters			
			208-230/1/60				Watts	115/1/60	230/1/60	460/1/60
			Amps	Watts	MCA	MOPD		Total Amps		
6	BEL0040*S6HEA	1/20	0.5	59	0.6	15	150	1.3	0.7	0.3
6	BEL0045*S6HEA	1/20	0.5	59	0.6	15	150	1.3	0.7	0.3
6	BEL0065*S6HEA	1/20	1.0	118	1.1	15	300	2.6	1.3	0.7
6	BEL0080*S6HEA	1/20	1.0	118	1.1	15	300	2.6	1.3	0.7
6	BEL0100*S6HEA	1/20	1.0	118	1.1	15	300	2.6	1.3	0.7
6	BEL0130*S6HEA	1/20	1.5	177	1.6	15	450	3.9	2.0	1.0
6	BEL0155*S6HEA	1/20	1.5	177	1.6	15	450	3.9	2.0	1.0
6	BEL0170*S6HEA	1/20	2.0	236	2.1	15	600	5.2	2.6	1.3
6	BEL0205*S6HEA	1/20	2.0	236	2.1	15	600	5.2	2.6	1.3
6	BEL0240*S6HEA	1/20	2.5	295	2.6	15	750	6.5	3.3	1.6
6	BEL0255*S6HEA	1/20	3.0	354	3.1	15	900	7.8	3.9	2.0
6	BEL0310*S6HEA	1/20	3.0	354	3.1	15	900	7.8	3.9	2.0
4	BEL0045*S4HEA	1/20	0.5	59	0.6	15	150	1.3	0.7	0.3
4	BEL0070*S4HEA	1/20	1.0	118	1.1	15	300	2.6	1.3	0.7
4	BEL0090*S4HEA	1/20	1.0	118	1.1	15	300	2.6	1.3	0.7
4	BEL0135*S4HEA	1/20	1.5	177	1.6	15	450	3.9	2.0	1.0
4	BEL0180*S4HEA	1/20	2.0	236	2.1	15	600	5.2	2.6	1.3
4	BEL0220*S4HEA	1/20	2.5	295	2.6	15	750	6.5	3.3	1.6
4	BEL0275*S4HEA	1/20	3.0	354	3.1	15	900	7.8	3.9	2.0

Notes:

* = Electrical Code Designator (see Nomenclature details)

SPECIFICATIONS

Hot Gas Defrost- 60 Hz

Please consult AWEF table on pages 46 & 47 to confirm model meets DOE minimum AWEF

FPI	New Model	HP	PSC Motor (Totally Enclosed)				Drain Pan Heaters			
			115/1/60				Watts	115/1/60	230/1/60	460/1/60
			Amps	Watts	MCA	MOPD		Total Amps		
6	BEL0040*S6HCA	1/20	1.0	82	1.3	20	150	1.3	0.7	0.3
6	BEL0045*S6HCA	1/20	1.0	82	1.3	20	150	1.3	0.7	0.3
6	BEL0065*S6HCA	1/20	2.0	164	2.3	20	300	2.6	1.3	0.7
6	BEL0080*S6HCA	1/20	2.0	164	2.3	20	300	2.6	1.3	0.7
6	BEL0100*S6HCA	1/20	2.0	164	2.3	20	300	2.6	1.3	0.7
6	BEL0130*S6HCA	1/20	3.0	246	3.3	20	450	3.9	2.0	1.0
6	BEL0155*S6HCA	1/20	3.0	246	3.3	20	450	3.9	2.0	1.0
6	BEL0170*S6HCA	1/20	4.0	328	4.3	20	600	5.2	2.6	1.3
6	BEL0205*S6HCA	1/20	4.0	328	4.3	20	600	5.2	2.6	1.3
6	BEL0240*S6HCA	1/20	5.0	410	5.3	20	750	6.5	3.3	1.6
6	BEL0255*S6HCA	1/20	6.0	492	6.3	20	900	7.8	3.9	2.0
6	BEL0310*S6HCA	1/20	6.0	492	6.3	20	900	7.8	3.9	2.0
4	BEL0045*S4HCA	1/20	1.0	82	1.3	20	150	1.3	0.7	0.3
4	BEL0070*S4HCA	1/20	2.0	164	2.3	20	300	2.6	1.3	0.7
4	BEL0090*S4HCA	1/20	2.0	164	2.3	20	300	2.6	1.3	0.7
4	BEL0135*S4HCA	1/20	3.0	246	3.3	20	450	3.9	2.0	1.0
4	BEL0180*S4HCA	1/20	4.0	328	4.3	20	600	5.2	2.6	1.3
4	BEL0220*S4HCA	1/20	5.0	410	5.3	20	750	6.5	3.3	1.6
4	BEL0275*S4HCA	1/20	6.0	492	6.3	20	900	7.8	3.9	2.0

FPI	New Model	HP	PSC Motor (Totally Enclosed)				Drain Pan Heaters			
			208-230/1/60				Watts	115/1/60	230/1/60	460/1/60
			Amps	Watts	MCA	MOPD		Total Amps		
6	BEL0040*S6HCA	1/20	0.5	91	0.6	15	150	1.3	0.7	0.3
6	BEL0045*S6HCA	1/20	0.5	91	0.6	15	150	1.3	0.7	0.3
6	BEL0065*S6HCA	1/20	1.0	182	1.1	15	300	2.6	1.3	0.7
6	BEL0080*S6HCA	1/20	1.0	182	1.1	15	300	2.6	1.3	0.7
6	BEL0100*S6HCA	1/20	1.0	182	1.1	15	300	2.6	1.3	0.7
6	BEL0130*S6HCA	1/20	1.5	273	1.6	15	450	3.9	2.0	1.0
6	BEL0155*S6HCA	1/20	1.5	273	1.6	15	450	3.9	2.0	1.0
6	BEL0170*S6HCA	1/20	2.0	364	2.1	15	600	5.2	2.6	1.3
6	BEL0205*S6HCA	1/20	2.0	364	2.1	15	600	5.2	2.6	1.3
6	BEL0240*S6HCA	1/20	2.5	455	2.6	15	750	6.5	3.3	1.6
6	BEL0255*S6HCA	1/20	3.0	546	3.1	15	900	7.8	3.9	2.0
6	BEL0310*S6HCA	1/20	3.0	546	3.1	15	900	7.8	3.9	2.0
4	BEL0045*S4HCA	1/20	0.5	91	0.6	15	150	1.3	0.7	0.3
4	BEL0070*S4HCA	1/20	1.0	182	1.1	15	300	2.6	1.3	0.7
4	BEL0090*S4HCA	1/20	1.0	182	1.1	15	300	2.6	1.3	0.7
4	BEL0135*S4HCA	1/20	1.5	273	1.6	15	450	3.9	2.0	1.0
4	BEL0180*S4HCA	1/20	2.0	364	2.1	15	600	5.2	2.6	1.3
4	BEL0220*S4HCA	1/20	2.5	455	2.6	15	750	6.5	3.3	1.6
4	BEL0275*S4HCA	1/20	3.0	546	3.1	15	900	7.8	3.9	2.0

Notes:

* = Electrical Code Designator (see Nomenclature details)

SPECIFICATIONS

Hot Gas Defrost- 60 Hz

Please consult AWEF table on pages 46 & 47 to confirm model meets DOE minimum AWEF

FPI	New Model	HP	PSC Motor (Totally Enclosed)				Drain Pan Heaters			
			460/1/60				Watts	115/1/60	230/1/60	460/1/60
			Amps	Watts	MCA	MOPD		Total Amps		
6	BEL0040*S6HCA	1/20	0.4	117	0.5	15	150	1.3	0.7	0.3
6	BEL0045*S6HCA	1/20	0.4	117	0.5	15	150	1.3	0.7	0.3
6	BEL0065*S6HCA	1/20	0.8	234	0.9	15	300	2.6	1.3	0.7
6	BEL0080*S6HCA	1/20	0.8	234	0.9	15	300	2.6	1.3	0.7
6	BEL0100*S6HCA	1/20	0.8	234	0.9	15	300	2.6	1.3	0.7
6	BEL0130*S6HCA	1/20	1.2	351	1.3	15	450	3.9	2.0	1.0
6	BEL0155*S6HCA	1/20	1.2	351	1.3	15	450	3.9	2.0	1.0
6	BEL0170*S6HCA	1/20	1.6	468	1.7	15	600	5.2	2.6	1.3
6	BEL0205*S6HCA	1/20	1.6	468	1.7	15	600	5.2	2.6	1.3
6	BEL0240*S6HCA	1/20	2.0	585	2.1	15	750	6.5	3.3	1.6
6	BEL0255*S6HCA	1/20	2.4	702	2.5	15	900	7.8	3.9	2.0
6	BEL0310*S6HCA	1/20	2.4	702	2.5	15	900	7.8	3.9	2.0
4	BEL0045*S4HCA	1/20	0.4	117	0.5	15	150	1.3	0.7	0.3
4	BEL0070*S4HCA	1/20	0.8	234	0.9	15	300	2.6	1.3	0.7
4	BEL0090*S4HCA	1/20	0.8	234	0.9	15	300	2.6	1.3	0.7
4	BEL0135*S4HCA	1/20	1.2	351	1.3	15	450	3.9	2.0	1.0
4	BEL0180*S4HCA	1/20	1.6	468	1.7	15	600	5.2	2.6	1.3
4	BEL0220*S4HCA	1/20	2.0	585	2.1	15	750	6.5	3.3	1.6
4	BEL0275*S4HCA	1/20	2.4	702	2.5	15	900	7.8	3.9	2.0

Notes:

* = Electrical Code Designator (see Nomenclature details)

SPECIFICATIONS

Hot Gas Defrost- 50 Hz

Please consult AWEF table on pages 46 & 47 to confirm model meets DOE minimum AWEF

FPI	New Model	HP	2-Speed EC Motor (Totally Enclosed)				Drain Pan Heaters	
			220/1/50				Watts	220/1/50
			Amps	Watts	MCA	MOPD		Total Amps
6	BEL0040*S6HMA	1/20	0.5	55	0.6	15	135	0.6
6	BEL0045*S6HMA	1/20	0.5	55	0.6	15	135	0.6
6	BEL0065*S6HMA	1/20	1.0	110	1.1	15	275	1.2
6	BEL0080*S6HMA	1/20	1.0	110	1.1	15	275	1.2
6	BEL0100*S6HMA	1/20	1.0	110	1.1	15	275	1.2
6	BEL0130*S6HMA	1/20	1.5	165	1.6	15	410	1.9
6	BEL0155*S6HMA	1/20	1.5	165	1.6	15	410	1.9
6	BEL0170*S6HMA	1/20	2.0	220	2.1	15	550	2.5
6	BEL0205*S6HMA	1/20	2.0	220	2.1	15	550	2.5
6	BEL0240*S6HMA	1/20	2.5	275	2.6	15	690	3.1
6	BEL0255*S6HMA	1/20	3.0	330	3.1	15	825	3.7
6	BEL0310*S6HMA	1/20	3.0	330	3.1	15	825	3.7
4	BEL0045*S4HMA	1/20	0.5	55	0.6	15	135	0.6
4	BEL0070*S4HMA	1/20	1.0	110	1.1	15	275	1.2
4	BEL0090*S4HMA	1/20	1.0	110	1.1	15	275	1.2
4	BEL0135*S4HMA	1/20	1.5	165	1.6	15	410	1.9
4	BEL0180*S4HMA	1/20	2.0	220	2.1	15	550	2.5
4	BEL0220*S4HMA	1/20	2.5	275	2.6	15	690	3.1
4	BEL0275*S4HMA	1/20	3.0	330	3.1	15	825	3.7

FPI	New Model	HP	1-Speed EC Motor (Totally Enclosed)				Drain Pan Heaters	
			220/1/50				Watts	220/1/50
			Amps	Watts	MCA	MOPD		Total Amps
6	BEL0040*S6HEA	1/20	0.5	59	0.6	15	135	0.6
6	BEL0045*S6HEA	1/20	0.5	59	0.6	15	135	0.6
6	BEL0065*S6HEA	1/20	1.0	118	1.1	15	275	1.2
6	BEL0080*S6HEA	1/20	1.0	118	1.1	15	275	1.2
6	BEL0100*S6HEA	1/20	1.0	118	1.1	15	275	1.2
6	BEL0130*S6HEA	1/20	1.5	177	1.6	15	410	1.9
6	BEL0155*S6HEA	1/20	1.5	177	1.6	15	410	1.9
6	BEL0170*S6HEA	1/20	2.0	236	2.1	15	550	2.5
6	BEL0205*S6HEA	1/20	2.0	236	2.1	15	550	2.5
6	BEL0240*S6HEA	1/20	2.5	295	2.6	15	690	3.1
6	BEL0255*S6HEA	1/20	3.0	354	3.1	15	825	3.7
6	BEL0310*S6HEA	1/20	3.0	354	3.1	15	825	3.7
4	BEL0045*S4HEA	1/20	0.5	59	0.6	15	135	0.6
4	BEL0070*S4HEA	1/20	1.0	118	1.1	15	275	1.2
4	BEL0090*S4HEA	1/20	1.0	118	1.1	15	275	1.2
4	BEL0135*S4HEA	1/20	1.5	177	1.6	15	410	1.9
4	BEL0180*S4HEA	1/20	2.0	236	2.1	15	550	2.5
4	BEL0220*S4HEA	1/20	2.5	295	2.6	15	690	3.1
4	BEL0275*S4HEA	1/20	3.0	354	3.1	15	825	3.7

Notes:

* = Electrical Code Designator (see Nomenclature details)

SPECIFICATIONS

Hot Gas Defrost- 50 Hz

Please consult AWEF table on pages 46 & 47 to confirm model meets DOE minimum AWEF

FPI	New Model	HP	PSC Motor (Totally Enclosed)				Drain Pan Heaters	
			220/1/50				Watts	220/1/50
			Amps	Watts	MCA	MOPD		Total Amps
6	BEL0040*S6HCA	1/20	0.5	65	0.6	15	135	0.6
6	BEL0045*S6HCA	1/20	0.5	65	0.6	15	135	0.6
6	BEL0065*S6HCA	1/20	1.0	130	1.1	15	275	1.2
6	BEL0080*S6HCA	1/20	1.0	130	1.1	15	275	1.2
6	BEL0100*S6HCA	1/20	1.0	130	1.1	15	275	1.2
6	BEL0130*S6HCA	1/20	1.5	195	1.6	15	410	1.9
6	BEL0155*S6HCA	1/20	1.5	195	1.6	15	410	1.9
6	BEL0170*S6HCA	1/20	2.0	260	2.1	15	550	2.5
6	BEL0205*S6HCA	1/20	2.0	260	2.1	15	550	2.5
6	BEL0240*S6HCA	1/20	2.5	325	2.6	15	690	3.1
6	BEL0255*S6HCA	1/20	3.0	390	3.1	15	825	3.7
6	BEL0310*S6HCA	1/20	3.0	390	3.1	15	825	3.7
4	BEL0045*S4HCA	1/20	0.5	65	0.6	15	135	0.6
4	BEL0070*S4HCA	1/20	1.0	130	1.1	15	275	1.2
4	BEL0090*S4HCA	1/20	1.0	130	1.1	15	275	1.2
4	BEL0135*S4HCA	1/20	1.5	195	1.6	15	410	1.9
4	BEL0180*S4HCA	1/20	2.0	260	2.1	15	550	2.5
4	BEL0220*S4HCA	1/20	2.5	325	2.6	15	690	3.1
4	BEL0275*S4HCA	1/20	3.0	390	3.1	15	825	3.7

Notes:

* = Electrical Code Designator (see Nomenclature details)

PHYSICAL DATA

Air Defrost (R-404A/R-507A, R-448A/R-449A, R-407A/R-407F, R-407C)

Model	No. of Fans	Coil Inlet OD	Suction OD	Equalizer OD	Drain MPT	Approx. Net Weight	
						lb	kg
BEL0045*S6A^A	1	1/2	1/2	1/4	3/4	33	15
BEL0055*S6A^A	1	1/2	5/8	1/4	3/4	36	16
BEL0060*S6A^A	1	1/2	5/8	1/4	3/4	36	16
BEL0095*S6A^A	2	1/2	5/8	1/4	3/4	51	23
BEL0105*S6A^A	2	1/2	5/8	1/4	3/4	52	24
BEL0115*S6A^A	2	1/2	5/8	1/4	3/4	56	26
BEL0125*S6A^A	2	1/2	7/8	1/4	3/4	56	26
BEL0155*S6A^A	3	1/2	7/8	1/4	3/4	67	30
BEL0190*S6A^A	3	1/2	7/8	1/4	3/4	73	33
BEL0250*S6A^A	4	1/2	7/8	1/4	3/4	94	43
BEL0295*S6A^A	5	1/2	7/8	1/4	3/4	115	52
BEL0350*S6A^A	6	1/2	1-1/8	1/4	3/4	133	60
BEL0380*S6A^A	6	1/2	1-1/8	1/4	3/4	137	62

Air Defrost (CO₂ DX)

Model	No. of Fans	Coil Inlet ²	Suction OD ²	Drain MPT	Approx. Net Weight	
					lb	kg
BEL0045*C6A^A	1	3/8	3/8	3/4	33	15
BEL0055*C6A^A	1	3/8	3/8	3/4	36	16
BEL0060*C6A^A	1	3/8	3/8	3/4	36	16
BEL0095*C6A^A	2	3/8	3/8	3/4	51	23
BEL0105*C6A^A	2	3/8	3/8	3/4	52	24
BEL0115*C6A^A	2	3/8	3/8	3/4	56	26
BEL0125*C6A^A	2	3/8	3/8	3/4	56	26
BEL0155*C6A^A	3	3/8	3/8	3/4	67	30
BEL0190*C6A^A	3	3/8	3/8	3/4	73	33
BEL0250*C6A^A	4	3/8	1/2	3/4	94	43
BEL0295*C6A^A	5	3/8	1/2	3/4	115	52
BEL0350*C6A^A	6	3/8	1/2	3/4	133	60
BEL0380*C6A^A	6	1/2	5/8	3/4	137	62

Notes:

* = Electrical Code Designator (see Nomenclature details)

^ = Motor Code Designator (see Nomenclature details)

² = Connection sizes may vary, if TD is lesser or greater than 10°F

PHYSICAL DATA

Electric Defrost (R-404A/R-507A, R-448A/R-449A, R-407A/R-407F, R-407C)

FPI	Model	No. of Fans	Coil Inlet OD	Suction OD	Equalizer OD	Drain MPT	Approx. Net Weight	
							lb	kg
6	BEL0040*S6E^A	1	1/2	5/8	1/4	3/4	36	16
6	BEL0045*S6E^A	1	1/2	5/8	1/4	3/4	38	17
6	BEL0065*S6E^A	2	1/2	5/8	1/4	3/4	54	24
6	BEL0080*S6E^A	2	1/2	5/8	1/4	3/4	54	24
6	BEL0100*S6E^A	2	1/2	7/8	1/4	3/4	59	27
6	BEL0130*S6E^A	3	1/2	7/8	1/4	3/4	71	32
6	BEL0155*S6E^A	3	1/2	1-1/8	1/4	3/4	78	35
6	BEL0170*S6E^A	4	1/2	7/8	1/4	3/4	91	41
6	BEL0205*S6E^A	4	1/2	1-1/8	1/4	3/4	100	45
6	BEL0240*S6E^A	5	1/2	1-1/8	1/4	3/4	120	54
6	BEL0255*S6E^A	6	1/2	1-1/8	1/4	3/4	134	61
6	BEL0310*S6E^A	6	1/2	1-1/8	1/4	3/4	146	66
4	BEL0045*S4E^A	1	1/2	5/8	1/4	3/4	38	17
4	BEL0070*S4E^A	2	1/2	5/8	1/4	3/4	53	24
4	BEL0090*S4E^A	2	1/2	7/8	1/4	3/4	59	27
4	BEL0135*S4E^A	3	1/2	7/8	1/4	3/4	77	35
4	BEL0180*S4E^A	4	1/2	1-1/8	1/4	3/4	100	45
4	BEL0220*S4E^A	5	1/2	1-1/8	1/4	3/4	119	54
4	BEL0275*S4E^A	6	1/2	1-1/8	1/4	3/4	142	64

Electric Defrost (CO₂ DX)

FPI	Model	No. of Fans	Coil Inlet ²	Suction OD ²	Drain MPT	Approx. Net Weight	
						lb	kg
6	BEL0040*C6E^A	1	3/8	3/8	3/4	36	16
6	BEL0045*C6E^A	1	3/8	3/8	3/4	38	17
6	BEL0065*C6E^A	2	3/8	3/8	3/4	54	24
6	BEL0080*C6E^A	2	3/8	1/2	3/4	54	24
6	BEL0100*C6E^A	2	3/8	1/2	3/4	59	27
6	BEL0130*C6E^A	3	3/8	1/2	3/4	71	32
6	BEL0155*C6E^A	3	3/8	1/2	3/4	78	35
6	BEL0170*C6E^A	4	3/8	1/2	3/4	91	41
6	BEL0205*C6E^A	4	3/8	1/2	3/4	100	45
6	BEL0240*C6E^A	5	3/8	5/8	3/4	120	54
6	BEL0255*C6E^A	6	3/8	5/8	3/4	134	61
6	BEL0310*C6E^A	6	3/8	5/8	3/4	146	66
4	BEL0045*C4E^A	1	3/8	3/8	3/4	38	17
4	BEL0070*C4E^A	2	3/8	3/8	3/4	53	24
4	BEL0090*C4E^A	2	3/8	1/2	3/4	59	27
4	BEL0135*C4E^A	3	3/8	1/2	3/4	77	35
4	BEL0180*C4E^A	4	3/8	1/2	3/4	100	45
4	BEL0220*C4E^A	5	3/8	1/2	3/4	119	54
4	BEL0275*C4E^A	6	3/8	5/8	3/4	142	64

Notes:

* = Electrical Code Designator (see Nomenclature details)

^ = Motor Code Designator (see Nomenclature details)

² = Connection sizes may vary, if TD is lesser or greater than 10⁰F

PHYSICAL DATA

Hot Gas Defrost

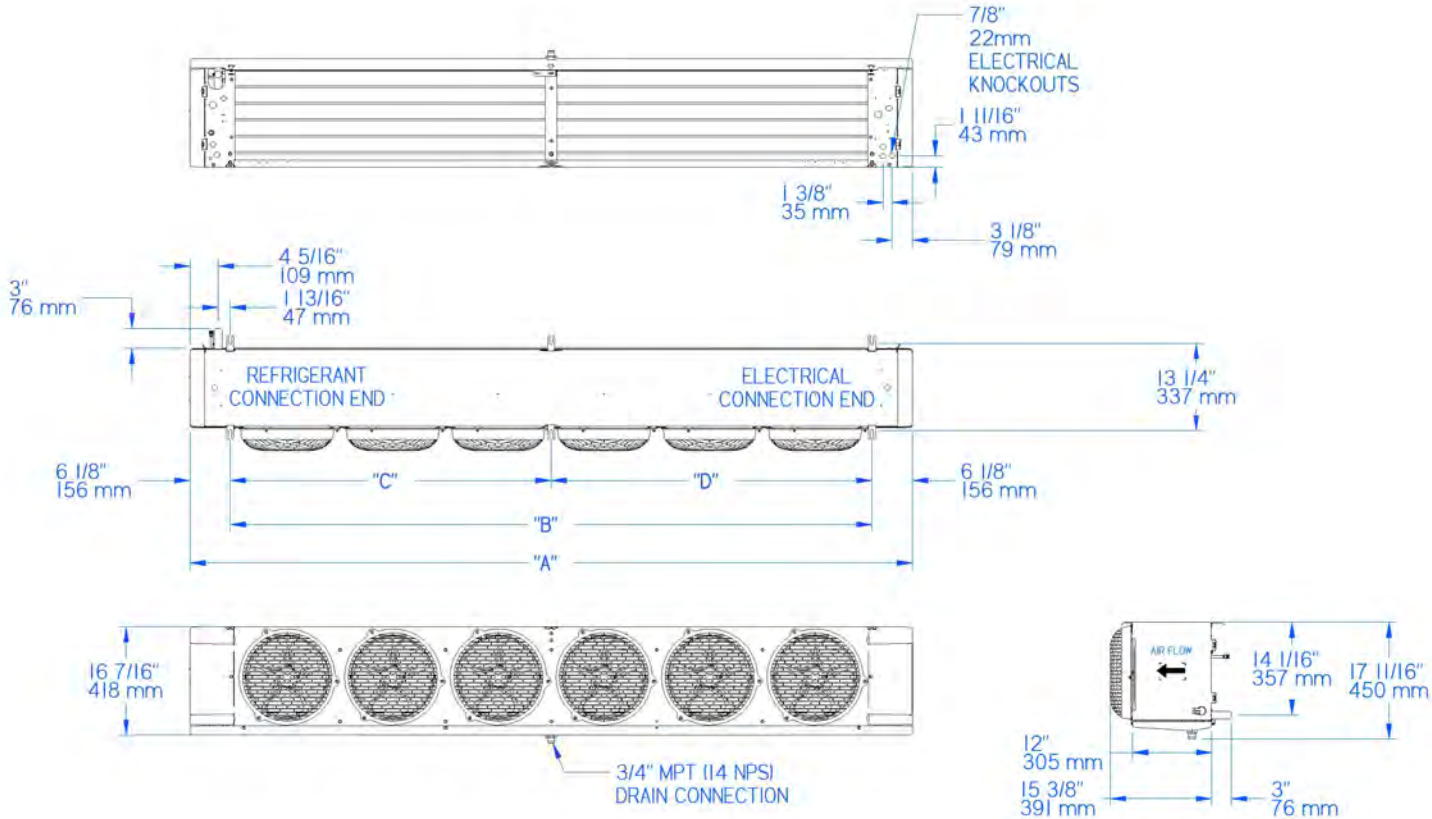
FPI	Model	No. of Fans	Coil Inlet OD	Suction OD	Equalizer OD	Drain MPT	Side Port OD	Hot Gas Pan Connection OD	Approx. Net Weight	
									lb	kg
6	BEL0040*S6H^A	1	1/2	5/8	1/4	3/4	1/2	5/8	38	17
6	BEL0045*S6H^A	1	1/2	5/8	1/4	3/4	1/2	5/8	40	18
6	BEL0065*S6H^A	2	1/2	5/8	1/4	3/4	1/2	5/8	56	25
6	BEL0080*S6H^A	2	1/2	5/8	1/4	3/4	1/2	5/8	56	25
6	BEL0100*S6H^A	2	1/2	7/8	1/4	3/4	1/2	5/8	61	27
6	BEL0130*S6H^A	3	1/2	7/8	1/4	3/4	1/2	5/8	73	33
6	BEL0155*S6H^A	3	1/2	1-1/8	1/4	3/4	1/2	5/8	80	36
6	BEL0170*S6H^A	4	1/2	7/8	1/4	3/4	1/2	5/8	93	42
6	BEL0205*S6H^A	4	1/2	1-1/8	1/4	3/4	1/2	5/8	102	46
6	BEL0240*S6H^A	5	1/2	1-1/8	1/4	3/4	1/2	5/8	122	55
6	BEL0255*S6H^A	6	1/2	1-1/8	1/4	3/4	1/2	5/8	136	62
6	BEL0310*S6H^A	6	1/2	1-1/8	1/4	3/4	1/2	5/8	148	67
4	BEL0045*S4H^A	1	1/2	5/8	1/4	3/4	1/2	5/8	40	18
4	BEL0070*S4H^A	2	1/2	5/8	1/4	3/4	1/2	5/8	55	25
4	BEL0090*S4H^A	2	1/2	7/8	1/4	3/4	1/2	5/8	61	28
4	BEL0135*S4H^A	3	1/2	7/8	1/4	3/4	1/2	5/8	79	36
4	BEL0180*S4H^A	4	1/2	1-1/8	1/4	3/4	1/2	5/8	102	46
4	BEL0220*S4H^A	5	1/2	1-1/8	1/4	3/4	1/2	5/8	121	55
4	BEL0275*S4H^A	6	1/2	1-1/8	1/4	3/4	1/2	5/8	144	65

Notes:

* = Electrical Code Designator (see Nomenclature details)

^ = Motor Code Designator (see Nomenclature details)

DIMENSIONAL DRAWINGS



No. of Fans	A		B		C		D	
	in.	mm	in.	mm	in.	mm	in.	mm
1	29.5	749	17.25	438	-	-	-	-
2	45.5	1,156	33.25	845	-	-	-	-
3	61.5	1,562	49.25	1,251	-	-	-	-
4	77.5	1,969	65.25	1,657	-	-	-	-
5	93.5	2,375	81.25	2,064	48.63	1,235	32.63	829
6	109.5	2,781	97.25	2,470	48.63	1,235	48.63	1,235

Note:
Hanger brackets will accept 3/8" / 9.5 mm hanger rods

DOE Rated AWEF

AWEF DATA

Air Defrost/2-Speed EC Motors

FPI	Model	Cooler				
		R-404A/ R-507A	R-448A/ R-449A	R-407A/ R-407F	R-407C	CO ₂ DX
		AWEF	AWEF	AWEF	AWEF	AWEF
6	BEL0045*±6AMA	9.00	9.00	9.00	9.00	9.00
6	BEL0055*±6AMA	9.00	9.00	9.00	9.00	9.00
6	BEL0060*±6AMA	9.00	9.00	9.00	9.00	9.00
6	BEL0095*±6AMA	9.00	9.00	9.00	9.00	9.00
6	BEL0105*±6AMA	9.00	9.00	9.00	9.00	9.00
6	BEL0115*±6AMA	9.00	9.00	9.00	9.00	9.00
6	BEL0125*±6AMA	9.00	9.00	9.00	9.00	9.00
6	BEL0155*±6AMA	9.00	9.00	9.00	9.00	9.00
6	BEL0190*±6AMA	9.00	9.00	9.00	9.00	9.00
6	BEL0250*±6AMA	9.00	9.00	9.00	9.00	9.00
6	BEL0295*±6AMA	9.00	9.00	9.00	9.00	9.00
6	BEL0350*±6AMA	9.00	9.00	9.00	9.00	9.00
6	BEL0380*±6AMA	9.00	9.00	9.00	9.00	9.00

DOE Rated AWEF

AWEF DATA

Electric Defrost/1-Speed EC Motors

FPI	Model	Freezer				
		R-404A/ R-507A	R-448A/ R-449A	R-407A/ R-407F	R-407C	CO ₂ DX
		AWEF	AWEF	AWEF	AWEF	AWEF
6	BEL0040*±6EEA	3.96	3.96	3.96	-	3.96
6	BEL0045*±6EEA	3.96	3.96	3.96	-	3.96
6	BEL0065*±6EEA	4.00	4.03	4.02	-	4.00
6	BEL0080*±6EEA	4.03	4.03	4.03	-	4.03
6	BEL0100*±6EEA	4.00	4.06	4.06	-	4.00
6	BEL0130*±6EEA	4.09	4.09	4.09	-	4.09
6	BEL0155*±6EEA	4.10	4.10	4.10	-	4.10
6	BEL0170*±6EEA	4.14	4.14	4.14	-	4.14
6	BEL0205*±6EEA	4.15	4.15	4.15	-	4.15
6	BEL0240*±6EEA	4.15	4.15	4.15	-	4.15
6	BEL0255*±6EEA	4.15	4.15	4.15	-	4.15
6	BEL0310*±6EEA	4.15	4.15	4.15	-	4.15
4	BEL0045*±4EEA	3.96	3.96	3.96	-	3.96
4	BEL0070*±4EEA	3.99	3.99	3.99	-	-
4	BEL0090*±4EEA	4.02	4.02	4.02	-	4.02
4	BEL0135*±4EEA	4.07	4.07	4.07	-	4.07
4	BEL0180*±4EEA	4.12	4.12	4.12	-	4.12
4	BEL0220*±4EEA	4.15	4.15	4.15	-	4.15
4	BEL0275*±4EEA	4.15	4.15	4.15	-	4.15

DOE Rated AWEF

AWEF DATA

Electric Defrost/2-Speed EC Motors

FPI	Model	Cooler				
		R-404A/ R-507A	R-448A/ R-449A	R-407A/ R-407F	R-407C	CO ₂ DX
		AWEF	AWEF	AWEF	AWEF	AWEF
6	BEL0040*±6EMA	9.00	9.00	9.00	-	9.00
6	BEL0045*±6EMA	9.00	9.00	9.00	-	9.00
6	BEL0065*±6EMA	9.00	9.00	9.00	-	9.00
6	BEL0080*±6EMA	9.00	9.00	9.00	-	9.00
6	BEL0100*±6EMA	9.00	9.00	9.00	-	9.00
6	BEL0130*±6EMA	9.00	9.00	9.00	-	9.00
6	BEL0155*±6EMA	9.00	9.00	9.00	-	9.00
6	BEL0170*±6EMA	9.00	9.00	9.00	-	9.00
6	BEL0205*±6EMA	9.00	9.00	9.00	-	9.00
6	BEL0240*±6EMA	9.00	9.00	9.00	-	9.00
6	BEL0255*±6EMA	9.00	9.00	9.00	-	9.00
6	BEL0310*±6EMA	9.00	9.00	9.00	-	9.00
4	BEL0045*±4EMA	9.00	9.00	9.00	-	9.00
4	BEL0070*±4EMA	9.00	9.00	9.00	-	-
4	BEL0090*±4EMA	9.00	9.00	9.00	-	9.00
4	BEL0135*±4EMA	9.00	9.00	9.00	-	9.00
4	BEL0180*±4EMA	9.00	9.00	9.00	-	9.00
4	BEL0220*±4EMA	9.00	9.00	9.00	-	9.00
4	BEL0275*±4EMA	9.00	9.00	9.00	-	9.00

FPI	Model	Freezer				
		R-404A/ R-507A	R-448A/ R-449A	R-407A/ R-407F	R-407C	CO ₂ DX
		AWEF	AWEF	AWEF	AWEF	AWEF
6	BEL0040*±6EMA	3.96	3.96	3.96	-	3.96
6	BEL0045*±6EMA	3.96	3.96	3.96	-	3.96
6	BEL0065*±6EMA	4.00	4.03	4.02	-	4.00
6	BEL0080*±6EMA	4.00	4.00	4.00	-	4.00
6	BEL0100*±6EMA	4.03	4.03	4.03	-	4.03
6	BEL0130*±6EMA	4.06	4.06	4.06	-	4.06
6	BEL0155*±6EMA	4.09	4.09	4.09	-	4.09
6	BEL0170*±6EMA	4.10	4.10	4.10	-	4.10
6	BEL0205*±6EMA	4.14	4.14	4.14	-	4.14
6	BEL0240*±6EMA	4.15	4.15	4.15	-	4.15
6	BEL0255*±6EMA	4.15	4.15	4.15	-	4.15
6	BEL0310*±6EMA	4.15	4.15	4.15	-	4.15
4	BEL0045*±4EMA	3.96	3.96	3.96	-	3.96
4	BEL0070*±4EMA	3.99	3.99	3.99	-	-
4	BEL0090*±4EMA	4.02	4.02	4.02	-	4.02
4	BEL0135*±4EMA	4.07	4.07	4.07	-	4.07
4	BEL0180*±4EMA	4.12	4.12	4.12	-	4.12
4	BEL0220*±4EMA	4.15	4.15	4.15	-	4.15
4	BEL0275*±4EMA	4.15	4.15	4.15	-	4.15

DOE Rated AWEF

AWEF DATA

Hot Gas Defrost/1-Speed EC Motors

FPI	Model	Freezer			
		R-404A/ R-507A	R-448A/ R-449A	R-407A/ R-407F	R-407C
		AWEF	AWEF	AWEF	AWEF
6	BEL0040*S6HEA	3.96	3.96	3.96	-
6	BEL0045*S6HEA	3.96	3.96	3.96	-
6	BEL0065*S6HEA	4.00	4.03	4.02	-
6	BEL0080*S6HEA	4.03	4.03	4.03	-
6	BEL0100*S6HEA	4.06	4.06	4.06	-
6	BEL0130*S6HEA	4.09	4.09	4.09	-
6	BEL0155*S6HEA	4.10	4.10	4.10	-
6	BEL0170*S6HEA	4.14	4.14	4.14	-
6	BEL0205*S6HEA	4.15	4.15	4.15	-
6	BEL0240*S6HEA	4.15	4.15	4.15	-
6	BEL0255*S6HEA	4.15	4.15	4.15	-
6	BEL0310*S6HEA	4.15	4.15	4.15	-
4	BEL0045*S4HEA	3.96	3.96	3.96	-
4	BEL0070*S4HEA	3.99	3.99	3.99	-
4	BEL0090*S4HEA	4.02	4.02	4.02	-
4	BEL0135*S4HEA	4.07	4.07	4.07	-
4	BEL0180*S4HEA	4.12	4.12	4.12	-
4	BEL0220*S4HEA	4.15	4.15	4.15	-
4	BEL0275*S4HEA	4.15	4.15	4.15	-

DOE Rated AWEF

AWEF DATA

Hot Gas Defrost/2-Speed EC Motors

FPI	Model	Cooler			
		R-404A/ R-507A	R-448A/ R-449A	R-407A/ R-407F	R-407C
		AWEF	AWEF	AWEF	AWEF
6	BEL0040*S6HMA	9.00	9.00	9.00	-
6	BEL0045*S6HMA	9.00	9.00	9.00	-
6	BEL0065*S6HMA	9.00	9.00	9.00	-
6	BEL0080*S6HMA	9.00	9.00	9.00	-
6	BEL0100*S6HMA	9.00	9.00	9.00	-
6	BEL0130*S6HMA	9.00	9.00	9.00	-
6	BEL0155*S6HMA	9.00	9.00	9.00	-
6	BEL0170*S6HMA	9.00	9.00	9.00	-
6	BEL0205*S6HMA	9.00	9.00	9.00	-
6	BEL0240*S6HMA	9.00	9.00	9.00	-
6	BEL0255*S6HMA	9.00	9.00	9.00	-
6	BEL0310*S6HMA	9.00	9.00	9.00	-
4	BEL0045*S4HMA	9.00	9.00	9.00	-
4	BEL0070*S4HMA	9.00	9.00	9.00	-
4	BEL0090*S4HMA	9.00	9.00	9.00	-
4	BEL0135*S4HMA	9.00	9.00	9.00	-
4	BEL0180*S4HMA	9.00	9.00	9.00	-
4	BEL0220*S4HMA	9.00	9.00	9.00	-
4	BEL0275*S4HMA	9.00	9.00	9.00	-

FPI	Model	Freezer			
		R-404A/ R-507A	R-448A/ R-449A	R-407A/ R-407F	R-407C
		AWEF	AWEF	AWEF	AWEF
6	BEL0040*S6HMA	3.96	3.96	3.96	-
6	BEL0045*S6HMA	3.96	3.96	3.96	-
6	BEL0065*S6HMA	4.00	4.03	4.02	-
6	BEL0080*S6HMA	4.00	4.00	4.00	-
6	BEL0100*S6HMA	4.03	4.03	4.03	-
6	BEL0130*S6HMA	4.06	4.06	4.06	-
6	BEL0155*S6HMA	4.09	4.09	4.09	-
6	BEL0170*S6HMA	4.10	4.10	4.10	-
6	BEL0205*S6HMA	4.14	4.14	4.14	-
6	BEL0240*S6HMA	4.15	4.15	4.15	-
6	BEL0255*S6HMA	4.15	4.15	4.15	-
6	BEL0310*S6HMA	4.15	4.15	4.15	-
4	BEL0045*S4HMA	3.96	3.96	3.96	-
4	BEL0070*S4HMA	3.99	3.99	3.99	-
4	BEL0090*S4HMA	4.02	4.02	4.02	-
4	BEL0135*S4HMA	4.07	4.07	4.07	-
4	BEL0180*S4HMA	4.12	4.12	4.12	-
4	BEL0220*S4HMA	4.15	4.15	4.15	-
4	BEL0275*S4HMA	4.15	4.15	4.15	-

HOT GAS REVERSE CYCLE KITS

Shipped Loose Accessories

FPI	Model	TXV Bypass and Liquid Line Piping Kit (Reverse Cycle)	TXV Liquid Line Piping Kit (Three Pipe or Rev Cycle w/o TXV Bypass)	Suction/Drain Pan Check Valve Piping Kit (Reverse Cycle)	Drain Pan Check Valve Piping Kit (Three Pipe)
		For TXV's SBF/SQE/BBI/EG	For TXV's SBF/SQE/BBI/EG		
6	BEL0040*S6H^A	50756301	50756302	50692204	50692302
6	BEL0045*S6H^A	50756301	50756302	50692204	50692302
6	BEL0065*S6H^A	50756301	50756302	50692204	50692302
6	BEL0080*S6H^A	50756301	50756302	50692204	50692302
6	BEL0100*S6H^A	50756301	50756302	50692225	50692302
6	BEL0130*S6H^A	50756301	50756302	50692225	50692302
6	BEL0155*S6H^A	50756301	50756302	50692206	50692302
6	BEL0170*S6H^A	50756301	50756302	50692205	50692302
6	BEL0205*S6H^A	50756301	50756302	50692206	50692302
6	BEL0240*S6H^A	50756301	50756302	50692206	50692302
6	BEL0255*S6H^A	50756301	50756302	50692206	50692302
6	BEL0310*S6H^A	50756301	50756302	50692206	50692302
4	BEL0045*S4H^A	50756301	50756302	50692204	50692302
4	BEL0070*S4H^A	50756301	50756302	50692204	50692302
4	BEL0090*S4H^A	50756301	50756302	50692205	50692302
4	BEL0135*S4H^A	50756301	50756302	50692205	50692302
4	BEL0180*S4H^A	50756301	50756302	50692206	50692302
4	BEL0220*S4H^A	50756301	50756302	50692206	50692302
4	BEL0275*S4H^A	50756301	50756302	50692206	50692302

REVERSE CYCLE PIPING

Reverse cycle defrost unit cooler operation

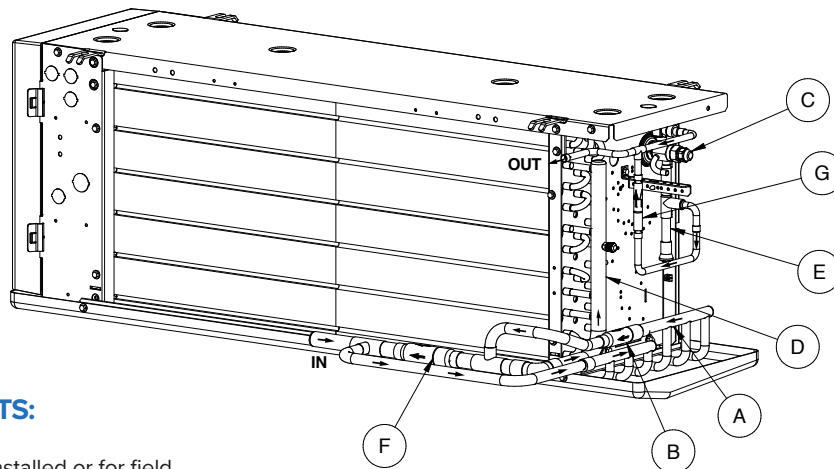
Reverse cycle defrost is a common method used in systems that include at least four unit coolers connected to a compressor rack. No more than 25% of the connected unit coolers are typically defrosted at the same time.

During reverse cycle, valving at the compressor rack diverts hot gas through the suction line to the defrosting unit cooler. See piping view in Figure 1. The suction line check valve directs the hot gas through the pan loop; heating the drain pan and preventing condensate from freezing during defrost. The hot gas exits the loop at the pan loop outlet header, passes through the drain pan check valve and enters the evaporator coil through the coil suction header. The hot refrigerant gas then flows through the defrosting coil, heating the finned surface and melting frost. As heat is transferred to the coil fins, hot refrigerant gas condenses to a liquid state. The refrigerant then exits the coil at the distributor side port, passes around the expansion valve through the bypass check valve and flows into the liquid refrigerant line. The liquid refrigerant then feeds other evaporators on the cooling cycle, evaporates, and returns to the compressor through their suction lines.

In some systems, electric drain pan heaters are used instead of a hot gas pan loop. Hot gas piping is simplified with the suction and drain pan check valves being eliminated. Electric drain pan heaters are energized during the defrost period, by a defrost control on the unit cooler or by a compressor rack controller.

REVERSE CYCLE DEFROST PIPING KEY COMPONENTS (FIG. 1)

- A. Hot gas drain pan loop
- B. Drain pan check valve
- C. Expansion valve
- D. Suction header
- E. Distributor
- F. Suction check valve
- G. Expansion valve bypass check valve



REVERSE CYCLE DEFROST PIPING KITS:

External check valve kit (available factory-installed or for field installation) includes suction check valve, drain pan check valve and piping to connect to suction header and hot gas drain pan loop. This kit is only necessary when the unit cooler is equipped with a hot gas drain pan loop.

Expansion valve bypass kit (available factory-installed or for field installation) includes expansion valve bypass check valve and piping to connect to the distributor side port and liquid line piping. The factory-installed version includes the expansion valve.

Use of external liquid/suction line heat exchanger with a reverse cycle system:

To increase the efficiency, higher performance and greater system protection, a heat exchanger may be beneficial to the system. In order to use a heat exchanger, the expansion valve bypass piping must be modified. See the piping view in Figure 2. The modification includes rerouting the pipe from the expansion valve bypass check valve to the inlet connection of the liquid line to the heat exchanger. A pipe needs to be routed from the liquid line outlet connection of the heat exchanger to the inlet connection of the thermostatic expansion valve.

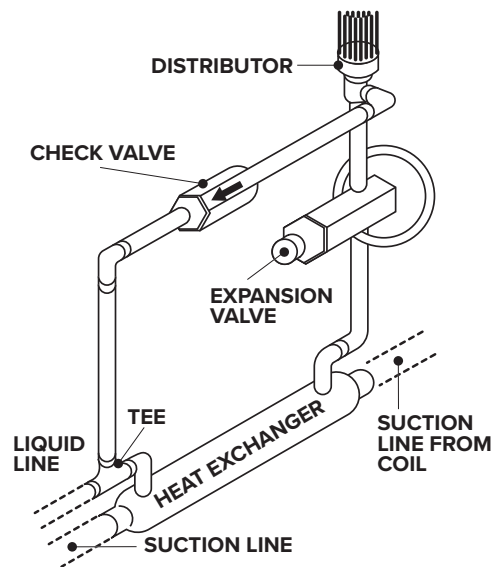


FIGURE 2. Typical Liquid Line Bypass Kit
(Shown assembled and modified for heat exchanger)

Three-pipe defrost unit cooler operation

Three-pipe defrost systems are connected to either a condensing unit or a compressor rack. No more than 33% of the connected unit coolers are typically defrosted at the same time.

During defrost, hot gas is directed through dedicated refrigerant piping (third pipe) to the defrosting unit cooler. See piping view in Figure 3. The hot gas enters the drain pan loop; heating the drain pan and preventing condensate from freezing during defrost. The hot gas exits the loop at the pan loop outlet header, passes through the drain pan check valve and enters the evaporator coil through the distributor side port connection. The hot refrigerant gas then flows through the defrosting coil, heating the finned surface and melting frost. As heat is transferred to the coil fins, hot refrigerant gas condenses to a liquid state. The refrigerant then exits the coil at the suction header.

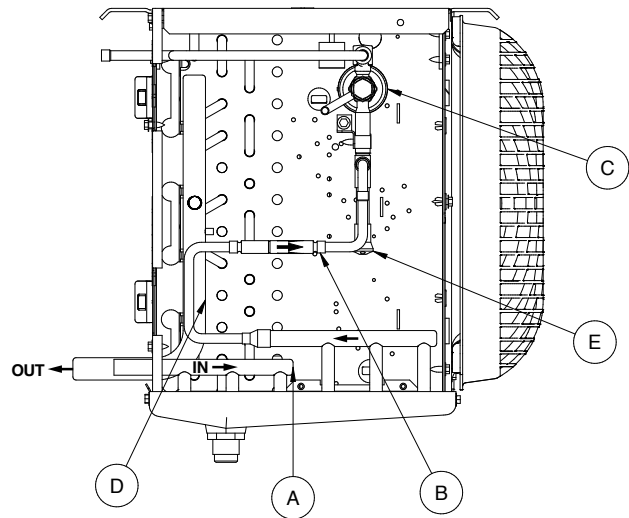
Three-pipe defrost unit cooler operation (cont.)

In some systems, electric drain pan heaters are used instead of a hot gas pan loop. Hot gas piping is simplified with the drain pan check valve being eliminated. Electric drain pan heaters are energized during the defrost period, by a defrost control on the unit cooler or by a compressor rack controller.

In order to provide sufficient re-evaporation of the liquid vapor mixture and sufficient heat for defrost, no more than one-third of the system should be defrosted at one time. Some means of control in the 3-pipe hot gas system should be supplied to regulate the large amount of liquid returning to the compressor, refrigerant slugging can otherwise damage the compressor.

REVERSE CYCLE THREE-PIPE DEFROST PIPING KEY COMPONENTS (FIG. 3)

- A. Hot gas drain pan loop
- B. Drain pan check valve
- C. Expansion valve
- D. Suction header
- E. Distributor



THREE-PIPE DEFROST PIPING KIT:

Three-pipe check valve kit (available factory-installed or for field installation) includes drain pan check valve and piping to connect the distributor side port to the hot gas drain pan loop. This kit is only necessary when the unit cooler is equipped with a hot gas drain pan loop.

Hot gas defrost controls:

Hot gas unit coolers are factory equipped with temperature control(s) that terminate the defrost cycle when the evaporator coil is clear of frost. After defrost, the control(s) keep the evaporator fans from re-energizing until the coil temperature is close to the freezing point.

STANDARD:

The standard control scheme includes an electromechanical defrost termination / fan delay control.

For reverse cycle defrost, the control sensing bulb is placed on the expansion valve bypass line, between the distributor side port and the expansion valve bypass check valve.

For three-pipe defrost, the control sensing bulb is placed on the suction header or suction header outlet connection.

OPTIONAL:

The optional control scheme includes an electromechanical defrost termination control and a separate bimetallic fan delay control. This scheme provides more options for the placement of the control sensing bulb as the defrost termination and fan delay sensing points are no longer combined.

The fan delay temperature is sensed on the evaporator coil endplate adjacent to the fins.

For reverse cycle defrost, the control sensing bulb is placed on the expansion valve bypass line or liquid line piping adjacent to the unit cooler.

For three-pipe defrost, the control sensing bulb is placed on the suction header or suction header outlet connection.

REPLACEMENT PARTS

Motor/Motor Mounts

Part #	Motor Type	Voltage	Motor Speeds	Motor Mount
25312501S / 25329001S	EC	115	1-SP / 2-SP	23108401*
25312601S / 25329101S	EC	208-230	2-SP	23108401*
25317701S	EC	208-230	1-SP	23108401
25309501S	PSC	115	1-SP	23108401
25309801S	PSC	208-230	1-SP	23108401
25309701S	PSC	460	1-SP	23106401

* = Consult factory when replacing motor mounts for motors 25329001S / 23529101S

Fan Blade

Part #	Description
5140C	Fan Blade 12" Std
5110E	Fan Blade 12" Reverse Air Flow

Fan Guard

Part #	Description
37001601	Fan Guard Wire Blue
37001801	Fan Guard Molded Blue

Cabinet Components

Part #	No. of Fans	Description	Defrost Type	Cabinet Aluminum	Application Notes
40594101	1	Drain Pan	Air/Hot Gas	Aluminum	Air, Hot Gas Models w/Drain Pan Loop
40595101	1	Drain Pan	Air/Hot Gas	White Painted Aluminum	Air, Hot Gas Models w/Drain Pan Loop
40596101	1	Drain Pan	Air/Hot Gas	Stainless Steel	Air Defrost Only
40594201	2	Drain Pan	Air/Hot Gas	Aluminum	Air, Hot Gas Models w/Drain Pan Loop
40595201	2	Drain Pan	Air/Hot Gas	White Painted Aluminum	Air, Hot Gas Models w/Drain Pan Loop
40596201	2	Drain Pan	Air/Hot Gas	Stainless Steel	Air Defrost Only
40594301	3	Drain Pan	Air/Hot Gas	Aluminum	Air, Hot Gas Models w/Drain Pan Loop
40595301	4	Drain Pan	Air/Hot Gas	White Painted Aluminum	Air, Hot Gas Models w/Drain Pan Loop
40596301	4	Drain Pan	Air/Hot Gas	Stainless Steel	Air Defrost Only
40594401	4	Drain Pan	Air/Hot Gas	Aluminum	Air, Hot Gas Models w/Drain Pan Loop
40595401	4	Drain Pan	Air/Hot Gas	White Painted Aluminum	Air, Hot Gas Models w/Drain Pan Loop
40596401	4	Drain Pan	Air/Hot Gas	Stainless Steel	Air Defrost Only
40594501	5	Drain Pan	Air/Hot Gas	Aluminum	Air, Hot Gas Models w/Drain Pan Loop
40595501	5	Drain Pan	Air/Hot Gas	White Painted Aluminum	Air, Hot Gas Models w/Drain Pan Loop
40596501	5	Drain Pan	Air/Hot Gas	Stainless Steel	Air Defrost Only
40594601	6	Drain Pan	Air/Hot Gas	Aluminum	Air, Hot Gas Models w/Drain Pan Loop
40595601	6	Drain Pan	Air/Hot Gas	White Painted Aluminum	Air, Hot Gas Models w/Drain Pan Loop
40596601	6	Drain Pan	Air/Hot Gas	Stainless Steel	Air Defrost Only

REPLACEMENT PARTS

Cabinet Components (cont.)

Part #	No. of Fans	Description	Defrost Type	Cabinet Aluminum	Application Notes
40594102	1	Drain Pan	Electric/Hot Gas	Aluminum	Elec, Hot Gas Models w/Drain Pan Heater
40595102	1	Drain Pan	Electric/Hot Gas	White Painted Aluminum	Elec, Hot Gas Models w/Drain Pan Heater
40594202	2	Drain Pan	Electric/Hot Gas	Aluminum	Elec, Hot Gas Models w/Drain Pan Heater
40595202	2	Drain Pan	Electric/Hot Gas	White Painted Aluminum	Elec, Hot Gas Models w/Drain Pan Heater
40594302	3	Drain Pan	Electric/Hot Gas	Aluminum	Elec, Hot Gas Models w/Drain Pan Heater
40595302	3	Drain Pan	Electric/Hot Gas	White Painted Aluminum	Elec, Hot Gas Models w/Drain Pan Heater
40594402	4	Drain Pan	Electric/Hot Gas	Aluminum	Elec, Hot Gas Models w/Drain Pan Heater
40595402	4	Drain Pan	Electric/Hot Gas	White Painted Aluminum	Elec, Hot Gas Models w/Drain Pan Heater
40594502	5	Drain Pan	Electric/Hot Gas	Aluminum	Elec, Hot Gas Models w/Drain Pan Heater
40595502	5	Drain Pan	Electric/Hot Gas	White Painted Aluminum	Elec, Hot Gas Models w/Drain Pan Heater
40594602	6	Drain Pan	Electric/Hot Gas	Aluminum	Elec, Hot Gas Models w/Drain Pan Heater
40595602	6	Drain Pan	Electric/Hot Gas	White Painted Aluminum	Elec, Hot Gas Models w/Drain Pan Heater
40593703	1	Insulated Outer Drain Pan Assy	All	Aluminum	Includes Outer Cover and Insulation
40593704	1	Insulated Outer Drain Pan Assy	All	White Painted Aluminum	Includes Outer Cover and Insulation
40593002	1	Insulated Outer Drain Pan Assy	All	Stainless Steel	Includes Outer Cover and Insulation
40593803	2	Insulated Outer Drain Pan Assy	All	Aluminum	Includes Outer Cover and Insulation
40593804	2	Insulated Outer Drain Pan Assy	All	White Painted Aluminum	Includes Outer Cover and Insulation
40593102	2	Insulated Outer Drain Pan Assy	All	Stainless Steel	Includes Outer Cover and Insulation
40591503	3	Insulated Outer Drain Pan Assy	All	Aluminum	Includes Outer Cover and Insulation
40591504	3	Insulated Outer Drain Pan Assy	All	White Painted Aluminum	Includes Outer Cover and Insulation
40593202	3	Insulated Outer Drain Pan Assy	All	Stainless Steel	Includes Outer Cover and Insulation
40591603	4	Insulated Outer Drain Pan Assy	All	Aluminum	Includes Outer Cover and Insulation
40591604	4	Insulated Outer Drain Pan Assy	All	White Painted Aluminum	Includes Outer Cover and Insulation
40593302	4	Insulated Outer Drain Pan Assy	All	Stainless Steel	Includes Outer Cover and Insulation
40591703	5	Insulated Outer Drain Pan Assy	All	Aluminum	Includes Outer Cover and Insulation
40591704	5	Insulated Outer Drain Pan Assy	All	White Painted Aluminum	Includes Outer Cover and Insulation
40593402	5	Insulated Outer Drain Pan Assy	All	Stainless Steel	Includes Outer Cover and Insulation
40591803	6	Insulated Outer Drain Pan Assy	All	Aluminum	Includes Outer Cover and Insulation

REPLACEMENT PARTS

Cabinet Components (cont.)

Part #	No. of Fans	Description	Defrost Type	Cabinet Aluminum	Application Notes
40591804	6	Insulated Outer Drain Pan Assy	All	White Painted Aluminum	Includes Outer Cover and Insulation
40593502	6	Insulated Outer Drain Pan Assy	All	Stainless Steel	Includes Outer Cover and Insulation
41032901	All	Access Panel RH (Elect) End	All	Aluminum/Stainless Steel	All w/Unpainted Cabinet
41032902	All	Access Panel RH (Elect) End	All	White Painted Aluminum	All w/White Cabinet
41032801	All	Access Panel LH (Refrig) End	All	Aluminum/Stainless Steel	Standard w/Unpainted Cabinet
41032802	All	Access Panel LH (Refrig) End	All	White Painted Aluminum	Standard w/White Cabinet
41032803	All	Access Panel LH (Refrig) End	Air/Electric	Aluminum/Stainless Steel	IntelliGen/QRC/Beacon II w/Unpainted Cabinet
41032804	All	Access Panel LH (Refrig) End	Air/Electric	White Painted Aluminum	IntelliGen/QRC/Beacon II w/White Cabinet
41038401	All	Access Panel LH (Refrig) End	Air/Electric	Aluminum	Glycol/CO ₂ Overfeed Only
41038402	All	Access Panel LH (Refrig) End	Air/Electric	White Painted Aluminum	Glycol/CO ₂ Overfeed Only
41038501	All	Access Panel LH (Refrig) End	Air/Electric	Stainless Steel	Glycol/CO ₂ Overfeed Only
41038701	All	Access Panel RH (Elect) End	Air/Electric	Aluminum	Glycol/CO ₂
41038702	All	Access Panel RH (Elect) End	Air/Electric	White Painted Aluminum	Glycol/CO ₂
41038901	All	Access Panel RH (Elect) End	Air/Electric	Stainless Steel	Glycol/CO ₂

Drain Pan Heaters

Part #	No. of Fans	Voltage	Wattage	Defrost Type	Application Notes
24753101	1	115	150	Hot Gas	Hot Gas Models w/Drain Pan Heater
24753102	2	115	300	Hot Gas	Hot Gas Models w/Drain Pan Heater
24753103	3	115	450	Hot Gas	Hot Gas Models w/Drain Pan Heater
24753104	4	115	600	Hot Gas	Hot Gas Models w/Drain Pan Heater
24753105	5	115	750	Hot Gas	Hot Gas Models w/Drain Pan Heater
24753106	6	115	900	Hot Gas	Hot Gas Models w/Drain Pan Heater
24752501	1	230	150	Electric /Hot Gas	Elec, Hot Gas Models w/Drain Pan Heater
24752502	2	230	300	Electric /Hot Gas	Elec, Hot Gas Models w/Drain Pan Heater
24752503	3	230	450	Electric /Hot Gas	Elec, Hot Gas Models w/Drain Pan Heater
24752504	4	230	600	Electric /Hot Gas	Elec, Hot Gas Models w/Drain Pan Heater
24752505	5	230	750	Electric /Hot Gas	Elec, Hot Gas Models w/Drain Pan Heater
24752506	6	230	900	Electric /Hot Gas	Elec, Hot Gas Models w/Drain Pan Heater
24753201	1	460	150	Hot Gas	Hot Gas Models w/Drain Pan Heater
24753202	2	460	300	Hot Gas	Hot Gas Models w/Drain Pan Heater
24753203	3	460	450	Hot Gas	Hot Gas Models w/Drain Pan Heater
24753204	4	460	600	Hot Gas	Hot Gas Models w/Drain Pan Heater
24753205	5	460	750	Hot Gas	Hot Gas Models w/Drain Pan Heater
24753206	6	460	900	Hot Gas	Hot Gas Models w/Drain Pan Heater

REPLACEMENT PARTS

Coil Defrost Heaters

Part #	No. of Fans	Voltage	Wattage	Defrost Type
24752001	1	230	300	Electric
24752002	2	230	600	Electric
24752003	3	230	900	Electric
24752004	4	230	1,200	Electric
24752005	5	230	1,500	Electric
24752006	6	230	1,800	Electric
24754101*	1	230	150	Electric
24754102*	2	230	300	Electric
24754103*	3	230	450	Electric
24754104*	4	230	600	Electric
24754105*	5	230	750	Electric
24754106*	6	230	900	Electric

* = One used per 460V unit only, top coil heater position

Electrical Components

Part #	Description	Defrost Type	Application Notes
22597101	Terminal Board	Air	All
22597701	Terminal Board	Electric/Hot Gas	All
5709L	Defrost Termination/Fan Delay Thermostat	Electric	Fixed Bi-Metallic Control
5708L	Heater Limit Thermostat	Electric	Fixed Bi-Metallic Control
4267W	Defrost Termination/Fan Delay Thermostat	Electric/Hot Gas	Adjustable Control
28913901	Room Thermostat	Air/Electric	Room Thermostat Mech
28963201	Room Thermostat	Air/Electric	Room Thermostat Elec

Drain Fitting

Part #	Description	Application Notes
26925101	Drain Fitting Kit	All

STANDARD NOZZLE SELECTION

Air Defrost

Medium Temperature (25°F SST)								
Model	No. of Fans	Distributor Tube (in.)		No. of Circuits	Nozzle Selections			
		OD	Length		R-404A/R-507A	R-448A/R-449A	R-407A/R-407F	R-407C
BEL0045*S6A^A	1	3/16	15	1	-	-	-	-
BEL0055*S6A^A	1	3/16	15	2	L-1/3	L-1/2	L-1/3	L-1/3
BEL0060*S6A^A	1	3/16	15	2	L-1/2	L-3/4	L-1/2	L-1/2
BEL0095*S6A^A	2	3/16	15	2	L-1/2	L-3/4	L-1/2	L-1/2
BEL0105*S6A^A	2	3/16	15	3	L-3/4	L-1	L-3/4	L-3/4
BEL0115*S6A^A	2	3/16	15	4	L-1	L-1-1/2	L-1	L-1
BEL0125*S6A^A	2	3/16	15	4	L-1	L-1-1/2	L-1	L-1
BEL0155*S6A^A	3	3/16	15	4	L-1	L-1-1/2	L-1	L-1
BEL0190*S6A^A	3	3/16	15	6	L-1-1/2	L-2	L-1-1/2	L-1-1/2
BEL0250*S6A^A	4	3/16	15	6	L-1-1/2	L-2	L-1-1/2	L-1-1/2
BEL0295*S6A^A	5	3/16	15	6	L-2	L-2-1/2	L-1-1/2	L-1-1/2
BEL0350*S6A^A	6	3/16	15	7	L-2	L-3	L-2	L-2
BEL0380*S6A^A	6	3/16	15	8	L-2-1/2	L-3	L-2-1/2	L-2-1/2

Notes:

Nozzles sized for 90-100°F liquid temperature at expansion valve.
 Contact Application Engineering for guidance if:
 - Liquid temperature is not 90-100°F
 - Evaporator TD is not 10°-15°F (room temperature – saturated suction temperature)
 Caution: Refrigeration system will not perform properly without correct nozzle

STANDARD NOZZLE SELECTION

Electric Defrost

Low Temperature (-20°F SST)								
Model	No. of Fans	Distributor Tube (in.)		No. of Circuits	Nozzle Selections			
		OD	Length		R-404A/R-507A	R-448A/R-449A	R-407A/R-407F	R-407C
BEL0040*S6E^A	1	3/16	15	2	L-1/2	L-3/4	L-1/2	-
BEL0045*S6E^A	1	3/16	15	2	L-3/4	L-3/4	L-1/2	-
BEL0065*S6E^A	2	3/16	15	3	L-3/4	L-1	L-3/4	-
BEL0080*S6E^A	2	3/16	15	3	L-1	L-1-1/2	L-1	-
BEL0100*S6E^A	2	3/16	15	6	L-1-1/2	L-1-1/2	L-1	-
BEL0130*S6E^A	3	3/16	15	6	L-1-1/2	L-2	L-1-1/2	-
BEL0155*S6E^A	3	3/16	15	8	L-2	L-2-1/2	L-2	-
BEL0170*S6E^A	4	3/16	15	6	L-2	L-2-1/2	L-2	-
BEL0205*S6E^A	4	3/16	15	8	L-2-1/2	L-3	L-2	-
BEL0240*S6E^A	5	3/16	15	8	L-2-1/2	L-4	L-2-1/2	-
BEL0255*S6E^A	6	3/16	15	9	L-3	L-4	L-3	-
BEL0310*S6E^A	6	3/16	15	12	L-4	L-5	L-3	-
BEL0045*S4E^A	1	3/16	15	2	L-1/2	L-3/4	L-1/2	-
BEL0070*S4E^A	2	3/16	15	3	L-3/4	L-1	L-3/4	-
BEL0090*S4E^A	2	3/16	15	6	L-1	L-1-1/2	L-1	-
BEL0135*S4E^A	3	3/16	15	6	L-1-1/2	L-2	L-1-1/2	-
BEL0180*S4E^A	4	3/16	15	8	L-2	L-2-1/2	L-2	-
BEL0220*S4E^A	5	3/16	15	8	L-2	L-3	L-2	-
BEL0275*S4E^A	6	3/16	15	12	L-3	L-4	L-3	-

Medium Temperature (25°F SST)								
Model	No. of Fans	Distributor Tube (in.)		No. of Circuits	Nozzle Selections			
		OD	Length		R-404A/R-507A	R-448A/R-449A	R-407A/R-407F	R-407C
BEL0040*S6E^A	1	3/16	15	2	L-1/4	L-1/3	L-1/4	L-1/4
BEL0045*S6E^A	1	3/16	15	2	L-1/3	L-1/2	L-1/3	L-1/3
BEL0065*S6E^A	2	3/16	15	3	L-1/2	L-3/4	L-1/2	L-1/2
BEL0080*S6E^A	2	3/16	15	3	L-3/4	L-3/4	L-1/2	L-1/2
BEL0100*S6E^A	2	3/16	15	6	L-3/4	L-1	L-3/4	L-3/4
BEL0130*S6E^A	3	3/16	15	6	L-1	L-1-1/2	L-1	L-1
BEL0155*S6E^A	3	3/16	15	8	L-1	L-1-1/2	L-1	L-1
BEL0170*S6E^A	4	3/16	15	6	L-1-1/2	L-1-1/2	L-1-1/2	L-1-1/2
BEL0205*S6E^A	4	3/16	15	8	L-1-1/2	L-2	L-1-1/2	L-1-1/2
BEL0240*S6E^A	5	3/16	15	8	L-1-1/2	L-2	L-1-1/2	L-1-1/2
BEL0255*S6E^A	6	3/16	15	9	L-2	L-2-1/2	L-2	L-2
BEL0310*S6E^A	6	3/16	15	12	L-2	L-3	L-2	L-2
BEL0045*S4E^A	1	3/16	15	2	L-1/3	L-1/2	L-1/4	L-1/4
BEL0070*S4E^A	2	3/16	15	3	L-1/2	L-3/4	L-1/2	L-1/2
BEL0090*S4E^A	2	3/16	15	6	L-3/4	L-3/4	L-3/4	L-3/4
BEL0135*S4E^A	3	3/16	15	6	L-3/4	L-1	L-3/4	L-3/4
BEL0180*S4E^A	4	3/16	15	8	L-1	L-1-1/2	L-1	L-1
BEL0220*S4E^A	5	3/16	15	8	L-1-1/2	L-2	L-1-1/2	L-1-1/2
BEL0275*S4E^A	6	3/16	15	12	L-2	L-2-1/2	L-2	L-2

Notes:
 Nozzles sized for 90-100°F liquid temperature at expansion valve.
 Contact Application Engineering for guidance if:
 - Liquid temperature is not 90-100°F
 - Evaporator TD is not 10°-15°F (room temperature – saturated suction temperature)
 Caution: Refrigeration system will not perform properly without correct nozzle

STANDARD NOZZLE SELECTION

Hot Gas Defrost

Low Temperature (-20°F SST)

Model	No. of Fans	Distributor Tube (in.)		No. of Circuits	Nozzle Selections			
		OD	Length		R-404A/R-507A	R-448A/R-449A	R-407A/R-407F	R-407C
BEL0040*S6H^A	1	3/16	15	2	L-1/2	L-3/4	L-1/2	-
BEL0045*S6H^A	1	3/16	15	2	L-3/4	L-3/4	L-1/2	-
BEL0065*S6H^A	2	3/16	15	3	L-3/4	L-1	L-3/4	-
BEL0080*S6H^A	2	3/16	15	3	L-1	L-1-1/2	L-1	-
BEL0100*S6H^A	2	3/16	15	6	L-1-1/2	L-1-1/2	L-1	-
BEL0130*S6H^A	3	3/16	15	6	L-1-1/2	L-2	L-1-1/2	-
BEL0155*S6H^A	3	3/16	15	8	L-2	L-2-1/2	L-2	-
BEL0170*S6H^A	4	3/16	15	6	L-2	L-2-1/2	L-2	-
BEL0205*S6H^A	4	3/16	15	8	L-2-1/2	L-3	L-2	-
BEL0240*S6H^A	5	3/16	15	8	L-2-1/2	L-4	L-2-1/2	-
BEL0255*S6H^A	6	3/16	15	9	L-3	L-4	L-3	-
BEL0310*S6H^A	6	3/16	15	12	L-4	L-5	L-3	-
BEL0045*S4H^A	1	3/16	15	2	L-1/2	L-3/4	L-1/2	-
BEL0070*S4H^A	2	3/16	15	3	L-3/4	L-1	L-3/4	-
BEL0090*S4H^A	2	3/16	15	6	L-1	L-1-1/2	L-1	-
BEL0135*S4H^A	3	3/16	15	6	L-1-1/2	L-2	L-1-1/2	-
BEL0180*S4H^A	4	3/16	15	8	L-2	L-2-1/2	L-2	-
BEL0220*S4H^A	5	3/16	15	8	L-2	L-3	L-2	-
BEL0275*S4H^A	6	3/16	15	12	L-3	L-4	L-3	-

Medium Temperature (25°F SST)

Model	No. of Fans	Distributor Tube (in.)		No. of Circuits	Nozzle Selections			
		OD	Length		R-404A/R-507A	R-448A/R-449A	R-407A/R-407F	R-407C
BEL0040*S6H^A	1	3/16	15	2	L-1/4	L-1/3	L-1/4	L-1/4
BEL0045*S6H^A	1	3/16	15	2	L-1/3	L-1/2	L-1/3	L-1/3
BEL0065*S6H^A	2	3/16	15	3	L-1/2	L-3/4	L-1/2	L-1/2
BEL0080*S6H^A	2	3/16	15	3	L-3/4	L-3/4	L-1/2	L-1/2
BEL0100*S6H^A	2	3/16	15	6	L-3/4	L-1	L-3/4	L-3/4
BEL0130*S6H^A	3	3/16	15	6	L-1	L-1-1/2	L-1	L-1
BEL0155*S6H^A	3	3/16	15	8	L-1	L-1-1/2	L-1	L-1
BEL0170*S6H^A	4	3/16	15	6	L-1-1/2	L-1-1/2	L-1-1/2	L-1-1/2
BEL0205*S6H^A	4	3/16	15	8	L-1-1/2	L-2	L-1-1/2	L-1-1/2
BEL0240*S6H^A	5	3/16	15	8	L-1-1/2	L-2	L-1-1/2	L-1-1/2
BEL0255*S6H^A	6	3/16	15	9	L-2	L-2-1/2	L-2	L-2
BEL0310*S6H^A	6	3/16	15	12	L-2	L-3	L-2	L-2
BEL0045*S4H^A	1	3/16	15	2	L-1/3	L-1/2	L-1/4	L-1/4
BEL0070*S4H^A	2	3/16	15	3	L-1/2	L-3/4	L-1/2	L-1/2
BEL0090*S4H^A	2	3/16	15	6	L-3/4	L-3/4	L-3/4	L-3/4
BEL0135*S4H^A	3	3/16	15	6	L-3/4	L-1	L-3/4	L-3/4
BEL0180*S4H^A	4	3/16	15	8	L-1	L-1-1/2	L-1	L-1
BEL0220*S4H^A	5	3/16	15	8	L-1-1/2	L-2	L-1-1/2	L-1-1/2
BEL0275*S4H^A	6	3/16	15	12	L-2	L-2-1/2	L-2	L-2

Notes:

Nozzles sized for 90-100°F liquid temperature at expansion valve.
 Contact Application Engineering for guidance if:
 - Liquid temperature is not 90-100°F
 - Evaporator TD is not 10°-15°F (room temperature – saturated suction temperature)
 Caution: Refrigeration system will not perform properly without correct nozzle



2175 West Park Place Blvd.

Stone Mountain, GA 30087

Phone: 800.537.7775 · Fax: 770.465.5900

heatcraftprd.com

Since product improvement is a continuing effort, we reserve the right to make changes in specifications without notice.

BN-LOP-0622 | Version 004

©2022 Heatcraft Refrigeration Products LLC

LOW PROFILE UNIT COOLERS

Technical Guide
Including models meeting DOE minimum AWEF

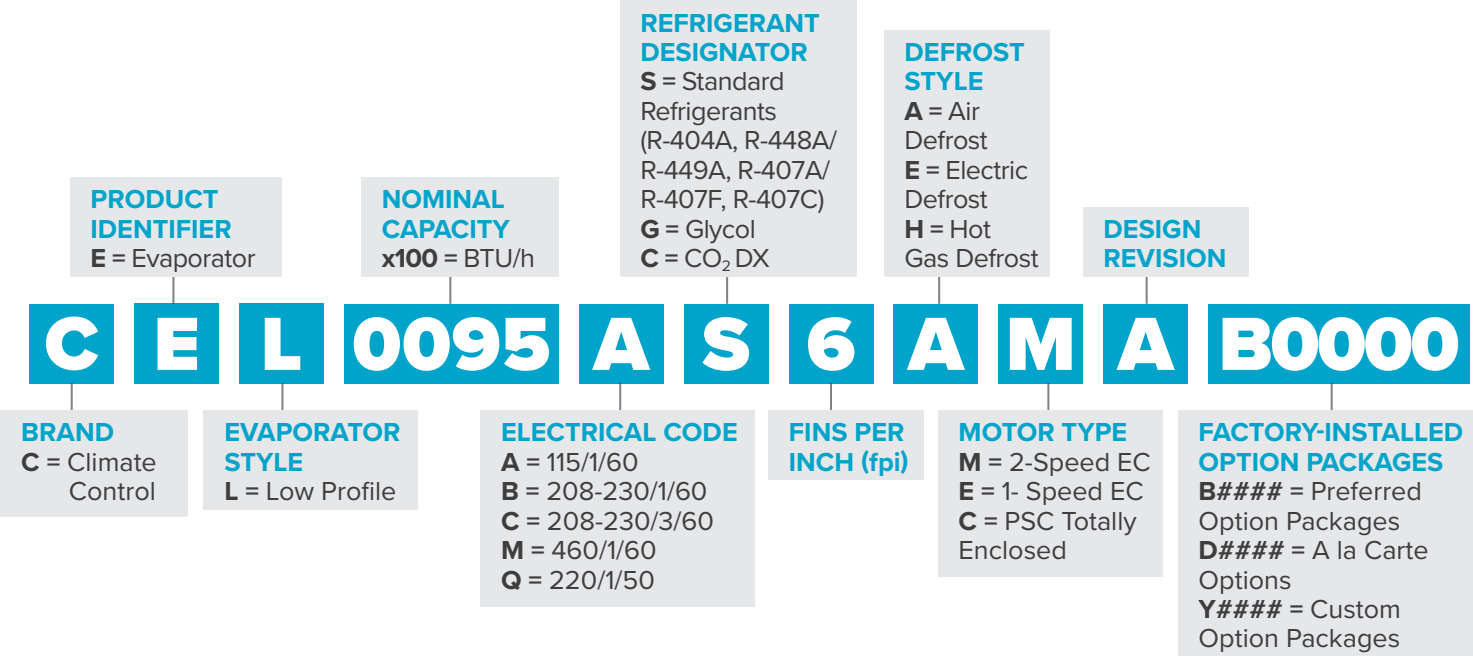


TABLE OF CONTENTS

3	Nomenclature
3	Preferred Option Packages
5	Features & Benefits
7	Air Defrost
7	Performance Data
7	Application Capacity: Air Defrost- 60 Hz
8	Application Capacity: Air Defrost- 60 Hz (CO ₂ DX)
9	Application Capacity: Air Defrost- 50 Hz (For PSC Motors) †
10	Application Capacity: Air Defrost- 50 Hz (CO ₂ DX)
11	Unit Specifications
14	Electric Defrost
14	Performance Data
14	Application Capacity: Low Temperature Electric Defrost- 60 Hz
16	Application Capacity: Low Temperature Electric Defrost- 60 Hz (CO ₂ DX)
17	Application Capacity: Low Temperature Electric Defrost- 50 Hz (For PSC Motors) †
19	Application Capacity: Low Temperature Electric Defrost- 50 Hz (CO ₂ DX)
20	Application Capacity: Medium Temperature Electric Defrost- 60 Hz
22	Application Capacity: Medium Temperature Electric Defrost- 60 Hz (CO ₂ DX)
23	Unit Specifications
	Hot Gas Defrost
27	Performance Data
27	Application Capacity: Low Temperature Hot Gas Defrost- 60 Hz
29	Application Capacity: Low Temperature Hot Gas Defrost- 50 Hz (For PSC Motors) †
31	Application Capacity: Medium Temperature Hot Gas Defrost- 60 Hz
33	Unit Specifications
39	Physical Data
42	Dimensional Drawings
	DOE Rated AWEF
43	AWEF
43	Air Defrost 2-Speed EC Motors
44	Electric Defrost 1-Speed EC Motors
45	Electric Defrost 2-Speed EC Motors
46	Hot Gas Defrost 1-Speed EC Motors
47	Hot Gas Defrost 2-Speed EC Motors
48	Hot Gas Defrost Reverse Cycle
48	Hot Gas Reverse Cycle Kits
48	Reverse Cycle Piping
51	Replacement Parts
51	Motor/Motor Mounts
51	Fan Blade/Fan Guard
51	Cabinet Components
53	Drain Pan Heaters
53	Coil Defrost Heaters
53	Electrical Components
53	Drain Fitting
55	Standard Nozzle Selection
55	Air Defrost
56	Electric Defrost
57	Hot Gas Defrost



NOMENCLATURE



PREFERRED OPTION PACKAGES

(HFC Refrigerants)

Package	Description (standard base model features + indicated options below)
B0000	Standard Base
B0100	Beacon II (R-404A/R-448A/R-449A)
B0101	Beacon II (R-407A/R-407C/R-407F)
B0200	intelliGen Refrigeration Controller (R-404A/R-448A/R-449A)
B0201	intelliGen Refrigeration Controller (R-407A/R-407C/R-407F)
B0300	Quick Response Controller (R-404A/R-448A/R-449A)
B0301	Quick Response Controller (R-407A/R-407C/R-407F)
B0403	Mounted Components (TXV, Solenoid Valve, Electronic T'Stat – R-404A)
B0404	Mounted Components (TXV, Solenoid Valve, Electronic T'Stat – R-407A/C/F)
B0405	Mounted Components (TXV, Solenoid Valve, Electronic T'Stat – R-448A/R-449A)

PREFERRED OPTION PACKAGES

(CO₂ DX)

Package	Description (standard base model features + indicated options below)
B0500 Standard Base	Danfoss EEV (120V) with 1/4" MPT Transducer Connection (Pressure Transducer not included)
B0501	Danfoss EEV (120V) with 1/4" MPT Transducer Connection (Pressure Transducer not included) + Filter Drier
B0502	Sporlan EEV (120V) with 1/4" MPT Transducer Connection (Pressure Transducer not included) + Filter Drier
B0503	Danfoss EEV (120V) with Danfoss Pressure Transducer
B0504	Danfoss EEV (120V) with Danfoss Pressure Transducer + Filter Drier
B0505	Danfoss EEV (120V) with CPC Pressure Transducer
B0506	Danfoss EEV (120V) with CPC Pressure Transducer + Filter Drier
B0507	Sporlan EEV (120V) with Microthermo Pressure Transducer + Filter Drier

FEATURES & BENEFITS

CABINET

- Cabinet design features hinged, removable front access panels on each side for easy access to electrical and refrigeration components.
- Molded fan guard and access panels are made of strong, durable, NSF and UL Sanitation rated lightweight and damage-resistant molded plastic material.
- Quick-removal fan guard/motor assembly for easier servicing of air mover parts.
- Sweat connections to reduce potential for leaks.
- Liquid line solenoid wire harness is factory-installed for quick installation.

COIL

- Internally enhanced tubing and fin design for higher efficiency.
- Coil heater slots have been enlarged for easier installation and replacement.
- Hot gas loop on bottom of coil for easier access is standard on hot gas defrost models.
- Fixed defrost termination for electric, adjustable defrost termination for hot gas.

CONTROLS OPTIONS

- **intelliGen™ Refrigeration Controller (iRC)**
 - Factory mounted, tested and calibrated with an electronic expansion valve, pressure transducer, temperature sensors, control board and User Interface. Standard features include Door Sensor, Product Load Input and Alarm Output.
 - Optional Field installable intelliGen™ Webserver Card (iWC) enables local and remote monitoring on any smart phone, tablet or PC.
 - Optional Field installable intelliGen™ Integration Card (iIC) enables connectivity to BACnet and Modbus.
- **Quick Response Controller** units include factory mounted electronic expansion valve, pressure transducer, temperature sensors and control board.
- **Beacon II™** units include factory mounted electronic expansion valve, pressure transducer, temperature sensors and control board.

MOTORS

- Motors plug into wiring harness for easier servicing.
- 2-Speed EC motors standard on Air Defrost models.
- 1-Speed EC motors standard on Electric Defrost & Hot Gas Defrost models.

DRAIN PAN

- Large diameter drain hole (3/4" ID) is located towards the back of the unit.
- Extended drain pan heaters for more uniform defrost throughout the drain pan and additional heat in end compartments.
- Hinged, removable drain pans allow for easy and safe access (3-6 fan units only).

OTHER OPTIONS

- Units available with factory installed mounted components: Expansion Valve, Mechanical Room Thermostat, Solenoid Valve with Dual Voltage Coil.
- Units available with mounted TXV and mounted TXV with solenoid valve.
 - Pre-assembled units come with mounted TXV, liquid line solenoid valve and room thermostat.
 - Available in a master liquid line configuration.
 - Pre-charged units come with mounted TXV, liquid line solenoid valve, room thermostat and quick connect fittings.
- Units available with stainless steel housing and drain pan.
- All units come standard with aluminum fin, copper tube coils. Units available with various coil material / coating options including polyester fin coating, black electrostatic fin coating, copper fins and Bronz-Glow coil coating. Please review our price book for availability.
- Units available with insulated drain pan.

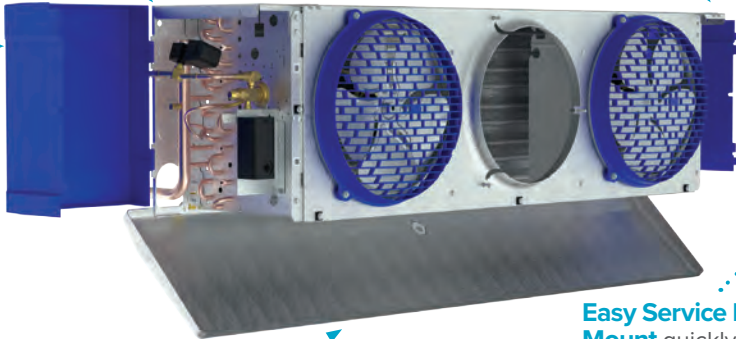
FEATURES & BENEFITS

OUTSTANDING FEATURES

Optional Factory Mounted Components
 Choose from Heatcraft's industry-leading IntelliGen™ Refrigeration Controller, Quick Response Controller, Beacon II Control or traditional mechanical components.

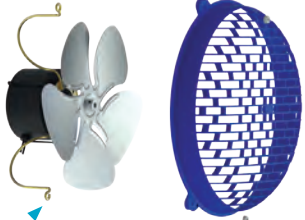
Composite Molded Access Panels have undergone extensive engineering and laboratory testing to ensure they are damage resistant from drops, dents, and bangs.

Hinged & Removeable Access Panels allow for easy access to both refrigeration and electrical end of Low Profile units.



Hinged Drain Pan improves access to service and clean the drain pan and coil. (3-6 fan models only)

Easy Service Motor Mount quickly and easily allows motor to be removed for service or replacement.



Re-Engineered Fan Guards have been redesigned for optimized air circulation and comply to new UL60335 safety standard.

Table 1: Capacity Correction Factors

Electric and Hot Gas Defrost Units				
Saturated Suction Temperature °F	+20	-10	-20	-30
Saturated Suction Temperature °C	-7	-23	-29	-34
Multiply Capacity By	1.15	1.04	1.00	0.90

PERFORMANCE DATA

Application Capacity: Air Defrost- 60 Hz

Please consult AWEF table on page 43 to confirm model meets DOE minimum AWEF

New Model	Legacy Model	R-404A/R-507A		R-448A/R-449A		Fan Data		
		Application Capacity ¹		Application Capacity ¹				
		10°F TD/25°F SST	6°C TD/-4°C SST	10°F TD/25°F SST	6°C TD/-4°C SST	No. of Fans	CFM	m ³ H
		BTUH	Watts	BTUH	Watts			
CEL0045*S6A^A	LSC040	4,000	1,200	4,600	1,300	1	653	1,109
CEL0055*S6A^A	LSC052	5,200	1,500	6,100	1,800	1	610	1,036
CEL0060*S6A^A	LSC065 LSC070	6,500	1,900	7,800	2,300	1	610	1,036
CEL0095*S6A^A	LSC070 LSC090	8,000	2,300	10,000	2,900	2	1,305	2,217
CEL0105*S6A^A	LSC090 LSC104	9,200	2,650	12,500	3,600	2	1,305	2,217
CEL0115*S6A^A	LSC120	11,700	3,370	14,500	4,180	2	1,220	2,073
CEL0125*S6A^A	LSC130	13,000	3,800	15,500	4,500	2	1,220	2,073
CEL0155*S6A^A	LSC140	14,000	4,100	16,800	4,900	3	1,958	3,327
CEL0190*S6A^A	LSC156 LSC180	18,000	5,300	21,200	6,200	3	1,830	3,109
CEL0250*S6A^A	LSC208	20,800	6,100	24,600	7,200	4	2,440	4,146
CEL0295*S6A^A	LSC260	26,000	7,600	30,700	9,000	5	3,050	5,182
CEL0350*S6A^A	LSC312	31,200	9,100	36,800	10,800	6	3,660	6,218
CEL0380*S6A^A	LSC370	37,000	10,800	44,400	13,000	6	3,660	6,218

New Model	Legacy Model	R-407A/R-407F		R-407C		Fan Data		
		Application Capacity ¹		Application Capacity ¹				
		10°F TD/25°F SST	6°C TD/-4°C SST	10°F TD/25°F SST	6°C TD/-4°C SST	No. of Fans	CFM	m ³ H
		BTUH	Watts	BTUH	Watts			
CEL0045*S6A^A	LSC040	4,600	1,300	4,600	1,300	1	653	1,109
CEL0055*S6A^A	LSC052	6,100	1,800	6,100	1,800	1	610	1,036
CEL0060*S6A^A	LSC065 LSC070	7,800	2,300	7,800	2,300	1	610	1,036
CEL0095*S6A^A	LSC070 LSC090	10,000	2,900	10,000	2,900	2	1,305	2,217
CEL0105*S6A^A	LSC090 LSC104	12,500	3,600	12,500	3,600	2	1,305	2,217
CEL0115*S6A^A	LSC120	14,500	4,180	14,500	4,180	2	1,220	2,073
CEL0125*S6A^A	LSC130	15,500	4,500	15,500	4,500	2	1,220	2,073
CEL0155*S6A^A	LSC140	16,800	4,900	16,800	4,900	3	1,958	3,327
CEL0190*S6A^A	LSC156 LSC180	21,200	6,200	21,200	6,200	3	1,830	3,109
CEL0250*S6A^A	LSC208	24,600	7,200	24,600	7,200	4	2,440	4,146
CEL0295*S6A^A	LSC260	30,700	9,000	30,700	9,000	5	3,050	5,182
CEL0350*S6A^A	LSC312	36,800	10,800	36,800	10,800	6	3,660	6,218
CEL0380*S6A^A	LSC370	44,400	13,000	44,400	13,000	6	3,660	6,218

Notes:

¹ = Capacities shown are Application Capacities reflecting nominal operation at 10°F TD. For models within the scope of the DOE AWEF (Annual Walk-in Energy Factor) standard, the Net Capacity is determined by the AHRI 1250 test method. DOE will publish this compliance data at www.regulations.doe.gov

* = Electrical Code Designator (see Nomenclature details)

^ = Motor Code Designator (see Nomenclature details)

Net Capacity is available upon request

PERFORMANCE DATA

Application Capacity: Air Defrost- 60 Hz

Please consult AWEF table on page 43 to confirm model meets DOE minimum AWEF

New Model	Legacy Model	CO ₂ DX		Fan Data		
		Application Capacity ¹				
		10°F TD/25°F SST	6°C TD/-4°C SST	No. of Fans	CFM	m ³ H
		BTUH	Watts			
CEL0045*C6A^A	N/A	4,600	1,348	1	653	1,109
CEL0055*C6A^A	N/A	6,100	1,788	1	610	1,036
CEL0060*C6A^A	N/A	7,800	2,286	1	610	1,036
CEL0095*C6A^A	N/A	10,000	2,931	2	1,305	2,217
CEL0105*C6A^A	N/A	12,500	3,663	2	1,305	2,217
CEL0115*C6A^A	N/A	14,500	4,250	2	1,220	2,073
CEL0125*C6A^A	N/A	15,500	4,543	2	1,220	2,073
CEL0155*C6A^A	N/A	16,800	4,924	3	1,958	3,327
CEL0190*C6A^A	N/A	21,200	6,213	3	1,830	3,109
CEL0250*C6A^A	N/A	24,600	7,210	4	2,440	4,146
CEL0295*C6A^A	N/A	30,700	8,997	5	3,050	5,182
CEL0350*C6A^A	N/A	36,800	10,785	6	3,660	6,218
CEL0380*C6A^A	N/A	44,400	13,012	6	3,660	6,218

Notes:

¹ = Capacities shown are Application Capacities reflecting nominal operation at 10°F TD. For models within the scope of the DOE AWEF (Annual Walk-in Energy Factor) standard, the Net Capacity is determined by the AHRI 1250 test method. DOE will publish this compliance data at www.regulations.doe.gov

* = Electrical Code Designator (see Nomenclature details)

^ = Motor Code Designator (see Nomenclature details)

Net Capacity is available upon request

PERFORMANCE DATA

Application Capacity: Air Defrost- 50 Hz (For PSC Motors)[†]

Please consult AWEF table on page 43 to confirm model meets DOE minimum AWEF

New Model	Legacy Model	R-404A/R-507A		R-448A/R-449A		Fan Data		
		Application Capacity ¹		Application Capacity ¹				
		10°F TD/25°F SST	6°C TD/-4°C SST	10°F TD/25°F SST	6°C TD/-4°C SST	No. of Fans	CFM	m ³ H
		BTUH	Watts	BTUH	Watts			
CEL0045*S6A^A	LSC040	3,800	1,140	4,370	1,235	1	588	999
CEL0055*S6A^A	LSC052	4,940	1,425	5,795	1,710	1	549	933
CEL0060*S6A^A	LSC065 LSC070	6,175	1,805	7,410	2,185	1	549	933
CEL0095*S6A^A	LSC070 LSC090	7,600	2,185	9,500	2,755	2	1,175	1,995
CEL0105*S6A^A	LSC090 LSC104	8,740	2,518	11,875	3,420	2	1,175	1,995
CEL0115*S6A^A	LSC120	11,115	3,202	13,775	3,971	2	1,098	1,866
CEL0125*S6A^A	LSC130	12,350	3,610	14,725	4,275	2	1,098	1,866
CEL0155*S6A^A	LSC140	13,300	3,895	15,960	4,655	3	1,762	2,994
CEL0190*S6A^A	LSC156 LSC180	17,100	5,035	20,140	5,890	3	1,647	2,798
CEL0250*S6A^A	LSC208	19,760	5,795	23,370	6,840	4	2,196	3,731
CEL0295*S6A^A	LSC260	24,700	7,220	29,165	8,550	5	2,745	4,664
CEL0350*S6A^A	LSC312	29,640	8,645	34,960	10,260	6	3,294	5,597
CEL0380*S6A^A	LSC370	35,150	10,260	42,180	12,350	6	3,294	5,597

New Model	Legacy Model	R-407A/R-407F		R-407C		Fan Data		
		Application Capacity ¹		Application Capacity ¹				
		10°F TD/25°F SST	6°C TD/-4°C SST	10°F TD/25°F SST	6°C TD/-4°C SST	No. of Fans	CFM	m ³ H
		BTUH	Watts	BTUH	Watts			
CEL0045*S6A^A	LSC040	4,370	1,235	4,370	1,235	1	588	999
CEL0055*S6A^A	LSC052	5,795	1,710	5,795	1,710	1	549	933
CEL0060*S6A^A	LSC065 LSC070	7,410	2,185	7,410	2,185	1	549	933
CEL0095*S6A^A	LSC070 LSC090	9,500	2,755	9,500	2,755	2	1,175	1,995
CEL0105*S6A^A	LSC090 LSC104	11,875	3,420	11,875	3,420	2	1,175	1,995
CEL0115*S6A^A	LSC120	13,775	3,971	13,775	3,971	2	1,098	1,866
CEL0125*S6A^A	LSC130	14,725	4,275	14,725	4,275	2	1,098	1,866
CEL0155*S6A^A	LSC140	15,960	4,655	15,960	4,655	3	1,762	2,994
CEL0190*S6A^A	LSC156 LSC180	20,140	5,890	20,140	5,890	3	1,647	2,798
CEL0250*S6A^A	LSC208	23,370	6,840	23,370	6,840	4	2,196	3,731
CEL0295*S6A^A	LSC260	29,165	8,550	29,165	8,550	5	2,745	4,664
CEL0350*S6A^A	LSC312	34,960	10,260	34,960	10,260	6	3,294	5,597
CEL0380*S6A^A	LSC370	42,180	12,350	42,180	12,350	6	3,294	5,597

Notes:

¹ = Capacities shown are Application Capacities reflecting nominal operation at 10°F TD. For models within the scope of the DOE AWEF (Annual Walk-in Energy Factor) standard, the Net Capacity is determined by the AHRI 1250 test method. DOE will publish this compliance data at www.regulations.doe.gov

* = Electrical Code Designator (see Nomenclature details)

^ = Motor Code Designator (see Nomenclature details)

Net Capacity is available upon request

[†] = For 1-speed and 2-speed EC motors, use 60 Hz capacity and airflow values. (units with EC motors operating at 50 Hz will not see a reduction in performance due to the electronic control of the motor)

PERFORMANCE DATA

Application Capacity: Air Defrost- 50 Hz (For PSC Motors)[†]

Please consult AWEF table on page 43 to confirm model meets DOE minimum AWEF

New Model	Legacy Model	CO ₂ DX		Fan Data		
		Application Capacity ¹				
		10°F TD/25°F SST	6°C TD/-4°C SST	No. of Fans	CFM	m ³ H
		BTUH	Watts			
CEL0045*C6A^A	N/A	4,370	1,281	1	588	999
CEL0055*C6A^A	N/A	5,795	1,698	1	549	933
CEL0060*C6A^A	N/A	7,410	2,172	1	549	933
CEL0095*C6A^A	N/A	9,500	2,784	2	1,175	1,996
CEL0105*C6A^A	N/A	11,875	3,480	2	1,175	1,996
CEL0115*C6A^A	N/A	13,775	4,037	2	1,098	1,866
CEL0125*C6A^A	N/A	14,725	4,315	2	1,098	1,866
CEL0155*C6A^A	N/A	15,960	4,677	3	1,762	2,994
CEL0190*C6A^A	N/A	20,140	5,902	3	1,647	2,798
CEL0250*C6A^A	N/A	23,370	6,849	4	2,196	3,731
CEL0295*C6A^A	N/A	29,165	8,547	5	2,745	4,664
CEL0350*C6A^A	N/A	34,960	10,246	6	3,294	5,597
CEL0380*C6A^A	N/A	42,180	12,362	6	3,294	5,597

Notes:

¹ = Capacities shown are Application Capacities reflecting nominal operation at 10°F TD. For models within the scope of the DOE AWEF (Annual Walk-in Energy Factor) standard, the Net Capacity is determined by the AHRI 1250 test method. DOE will publish this compliance data at www.regulations.doe.gov

* = Electrical Code Designator (see Nomenclature details)

^ = Motor Code Designator (see Nomenclature details)

Net Capacity is available upon request

[†] = For 1-speed and 2-speed EC motors, use 60 Hz capacity and airflow values. (units with EC motors operating at 50 Hz will not see a reduction in performance due to the electronic control of the motor)

SPECIFICATIONS

Air Defrost- 60 Hz

Please consult AWEF table on page 43 to confirm model meets DOE minimum AWEF

		2-Speed EC Motor (Totally Enclosed)							
		115/1/60				208-230/1/60			
New Model	HP	Amps	Watts	MCA	MOPD	Amps	Watts	MCA	MOPD
CEL0045*±6AMA	1/20	0.9	55	1.1	20	0.5	55	0.6	15
CEL0055*±6AMA	1/20	0.9	55	1.1	20	0.5	55	0.6	15
CEL0060*±6AMA	1/20	0.9	55	1.1	20	0.5	55	0.6	15
CEL0095*±6AMA	1/20	1.8	110	2.0	20	1.0	110	1.1	15
CEL0105*±6AMA	1/20	1.8	110	2.0	20	1.0	110	1.1	15
CEL0115*±6AMA	1/20	1.8	110	2.0	20	1.0	110	1.1	15
CEL0125*±6AMA	1/20	1.8	110	2.0	20	1.0	110	1.1	15
CEL0155*±6AMA	1/20	2.7	165	2.9	20	1.5	165	1.6	15
CEL0190*±6AMA	1/20	2.7	165	2.9	20	1.5	165	1.6	15
CEL0250*±6AMA	1/20	3.6	220	3.8	20	2.0	220	2.1	15
CEL0295*±6AMA	1/20	4.5	275	4.7	20	2.5	275	2.6	15
CEL0350*±6AMA	1/20	5.4	330	5.6	20	3.0	330	3.1	15
CEL0380*±6AMA	1/20	5.4	330	5.6	20	3.0	330	3.1	15

		1-Speed EC Motor (Totally Enclosed)							
		115/1/60				208-230/1/60			
New Model	HP	Amps	Watts	MCA	MOPD	Amps	Watts	MCA	MOPD
CEL0045*±6AEA	1/20	0.9	55	1.1	20	0.5	59	0.6	15
CEL0055*±6AEA	1/20	0.9	55	1.1	20	0.5	59	0.6	15
CEL0060*±6AEA	1/20	0.9	55	1.1	20	0.5	59	0.6	15
CEL0095*±6AEA	1/20	1.8	110	2.0	20	1.0	118	1.1	15
CEL0105*±6AEA	1/20	1.8	110	2.0	20	1.0	118	1.1	15
CEL0115*±6AEA	1/20	1.8	110	2.0	20	1.0	118	1.1	15
CEL0125*±6AEA	1/20	1.8	110	2.0	20	1.0	118	1.1	15
CEL0155*±6AEA	1/20	2.7	165	2.9	20	1.5	177	1.6	15
CEL0190*±6AEA	1/20	2.7	165	2.9	20	1.5	177	1.6	15
CEL0250*±6AEA	1/20	3.6	220	3.8	20	2.0	236	2.1	15
CEL0295*±6AEA	1/20	4.5	275	4.7	20	2.5	295	2.6	15
CEL0350*±6AEA	1/20	5.4	330	5.6	20	3.0	354	3.1	15
CEL0380*±6AEA	1/20	5.4	330	5.6	20	3.0	354	3.1	15

Notes:

* = Electrical Code Designator (see Nomenclature details)

± = Refrigerant Designator (see Nomenclature details)

SPECIFICATIONS

Air Defrost- 60 Hz

Please consult AWEF table on page 43 to confirm model meets DOE minimum AWEF

New Model	HP	PSC Motor (Totally Enclosed)											
		115/1/60				208-230/1/60				460/1/60			
		Amps	Watts	MCA	MOPD	Amps	Watts	MCA	MOPD	Amps	Watts	MCA	MOPD
CEL0045*±6ACA	1/20	1.0	82	1.3	20	0.5	91	0.6	15	0.4	117	0.5	15
CEL0055*±6ACA	1/20	1.0	82	1.3	20	0.5	91	0.6	15	0.4	117	0.5	15
CEL0060*±6ACA	1/20	1.0	82	1.3	20	0.5	91	0.6	15	0.4	117	0.5	15
CEL0095*±6ACA	1/20	2.0	164	2.3	20	1.0	182	1.1	15	0.8	234	0.9	15
CEL0105*±6ACA	1/20	2.0	164	2.3	20	1.0	182	1.1	15	0.8	234	0.9	15
CEL0115*±6ACA	1/20	2.0	164	2.3	20	1.0	182	1.1	15	0.8	234	0.9	15
CEL0125*±6ACA	1/20	2.0	164	2.3	20	1.0	182	1.1	15	0.8	234	0.9	15
CEL0155*±6ACA	1/20	3.0	246	3.3	20	1.5	273	1.6	15	1.2	351	1.3	15
CEL0190*±6ACA	1/20	3.0	246	3.3	20	1.5	273	1.6	15	1.2	351	1.3	15
CEL0250*±6ACA	1/20	4.0	328	4.3	20	2.0	364	2.1	15	1.6	468	1.7	15
CEL0295*±6ACA	1/20	5.0	410	5.3	20	2.5	455	2.6	15	2.0	585	2.1	15
CEL0350*±6ACA	1/20	6.0	492	6.3	20	3.0	546	3.1	15	2.4	702	2.5	15
CEL0380*±6ACA	1/20	6.0	492	6.3	20	3.0	546	3.1	15	2.4	702	2.5	15

Notes:

* = Electrical Code Designator (see Nomenclature details)

± = Refrigerant Designator (see Nomenclature details)

SPECIFICATIONS

Air Defrost- 50 Hz

Please consult AWEF table on page 43 to confirm model meets DOE minimum AWEF

New Model	HP	2-Speed EC Motor (Totally Enclosed)				1-Speed EC Motor (Totally Enclosed)				PSC Motor (Totally Enclosed)			
		220/1/50				220/1/50				220/1/50			
		Amps	Watts	MCA	MOPD	Amps	Watts	MCA	MOPD	Amps	Watts	MCA	MOPD
CEL0045*±6A^A	1/20	0.5	55	0.6	15	0.5	59	0.6	15	0.5	65	0.6	15
CEL0055*±6A^A	1/20	0.5	55	0.6	15	0.5	59	0.6	15	0.5	65	0.6	15
CEL0060*±6A^A	1/20	0.5	55	0.6	15	0.5	59	0.6	15	0.5	65	0.6	15
CEL0095*±6A^A	1/20	1.0	110	1.1	15	1.0	118	1.1	15	1.0	130	1.1	15
CEL0105*±6A^A	1/20	1.0	110	1.1	15	1.0	118	1.1	15	1.0	130	1.1	15
CEL0115*±6A^A	1/20	1.0	110	1.1	15	1.0	118	1.1	15	1.0	130	1.1	15
CEL0125*±6A^A	1/20	1.0	110	1.1	15	1.0	118	1.1	15	1.0	130	1.1	15
CEL0155*±6A^A	1/20	1.5	165	1.6	15	1.5	177	1.6	15	1.5	195	1.6	15
CEL0190*±6A^A	1/20	1.5	165	1.6	15	1.5	177	1.6	15	1.5	195	1.6	15
CEL0250*±6A^A	1/20	2.0	220	2.1	15	2.0	236	2.1	15	2.0	260	2.1	15
CEL0295*±6A^A	1/20	2.5	275	2.6	15	2.5	295	2.6	15	2.5	325	2.6	15
CEL0350*±6A^A	1/20	3.0	330	3.1	15	3.0	354	3.1	15	3.0	390	3.1	15
CEL0380*±6A^A	1/20	3.0	330	3.1	15	3.0	354	3.1	15	3.0	390	3.1	15

Notes:

* = Electrical Code Designator (see Nomenclature details)

^ = Motor Code Designator (see Nomenclature details)

± = Refrigerant Designator (see Nomenclature details)

PERFORMANCE DATA

Application Capacity: Low Temperature Electric Defrost- 60 Hz

Please consult AWEF table on pages 44 & 45 to confirm model meets DOE minimum AWEF

Please refer to Table 1: Capacity Correction Factors (page 6) if using Saturated Suction Temperatures different than listed in the information below

FPI	New Model	Legacy Model	R-404A/R-507A		R-448A/R-449A		Fan Data		
			Application Capacity ¹		Application Capacity ¹				
			10°F TD/-20°F SST	6°C TD/-29°C SST	10°F TD/-20°F SST	6°C TD/-29°C SST	No. of Fans	CFM	m ³ H
			BTUH	Watts	BTUH	Watts			
6	CEL0040*S6E^A	LSF035 LSF040	3,500	1,000	3,900	1,000	1	685	1,164
6	CEL0045*S6E^A	LSF040 LSF047	4,700	1,400	5,300	1,600	1	641	1,088
6	CEL0065*S6E^A	LSF065	6,500	1,900	7,200	2,100	2	1,371	2,329
6	CEL0080*S6E^A	LSF075	7,500	2,200	8,400	2,500	2	1,371	2,329
6	CEL0100*S6E^A	LSF090	9,000	2,600	9,900	2,900	2	1,281	2,176
6	CEL0130*S6E^A	LSF120	12,000	3,500	13,500	4,000	3	2,056	3,493
6	CEL0155*S6E^A	LSF140	14,000	4,100	16,000	4,700	3	1,922	3,265
6	CEL0170*S6E^A	LSF160	16,000	4,700	17,900	5,200	4	2,741	4,658
6	CEL0205*S6E^A	LSF180	18,000	5,300	20,100	5,900	4	2,562	4,353
6	CEL0240*S6E^A	LSF200	20,000	5,900	22,800	6,600	5	3,203	5,441
6	CEL0255*S6E^A	LSF240	24,000	7,000	26,900	7,900	6	4,112	6,986
6	CEL0310*S6E^A	LSF280	28,000	8,200	31,400	9,200	6	3,843	6,529
4	CEL0045*S4E^A	LFF041	4,100	1,200	4,500	1,300	1	667	1,132
4	CEL0070*S4E^A	LFF068	6,800	2,000	7,400	2,200	2	1,425	2,422
4	CEL0090*S4E^A	LFF080	8,000	2,300	8,800	2,600	2	1,332	2,263
4	CEL0135*S4E^A	LFF102	10,200	3,000	12,800	3,700	3	1,998	3,395
4	CEL0180*S4E^A	LFF136	13,600	4,000	17,300	5,000	4	2,664	4,527
4	CEL0220*S4E^A	LFF170	17,000	5,000	19,500	5,600	5	3,331	5,659
4	CEL0275*S4E^A	LFF204 LFF235	23,500	6,900	25,900	7,600	6	3,997	6,790

Notes:
¹ = Capacities shown are Application Capacities reflecting nominal operation at 10°F TD. For models within the scope of the DOE AWEF (Annual Walk-in Energy Factor) standard, the Net Capacity is determined by the AHRI 1250 test method. DOE will publish this compliance data at www.regulations.doe.gov
 * = Electrical Code Designator (see Nomenclature details)
 ^ = Motor Code Designator (see Nomenclature details)
 Net Capacity is available upon request

PERFORMANCE DATA

Application Capacity: Low Temperature Electric Defrost- 60 Hz

Please consult AWEF table on pages 44 & 45 to confirm model meets DOE minimum AWEF

Please refer to Table 1: Capacity Correction Factors (page 6) if using Saturated Suction Temperatures different than listed in the information below

FPI	New Model	Legacy Model	R-407A/R-407F		R-407C		Fan Data		
			Application Capacity ¹		Application Capacity ¹				
			10°F TD/-20°F SST	6°C TD/-29°C SST	10°F TD/-20°F SST	6°C TD/-29°C SST	No. of Fans	CFM	m ³ H
			BTUH	Watts	BTUH	Watts			
6	CEL0040*S6E^A	LSF035 LSF040	3,900	1,000	-	-	1	685	1,164
6	CEL0045*S6E^A	LSF040 LSF047	5,300	1,600	-	-	1	641	1,088
6	CEL0065*S6E^A	LSF065	7,200	2,100	-	-	2	1,371	2,329
6	CEL0080*S6E^A	LSF075	8,400	2,500	-	-	2	1,371	2,329
6	CEL0100*S6E^A	LSF090	9,900	2,900	-	-	2	1,281	2,176
6	CEL0130*S6E^A	LSF120	13,500	4,000	-	-	3	2,056	3,493
6	CEL0155*S6E^A	LSF140	16,000	4,700	-	-	3	1,922	3,265
6	CEL0170*S6E^A	LSF160	17,900	5,200	-	-	4	2,741	4,658
6	CEL0205*S6E^A	LSF180	20,100	5,900	-	-	4	2,562	4,353
6	CEL0240*S6E^A	LSF200	22,400	6,500	-	-	5	3,203	5,441
6	CEL0255*S6E^A	LSF240	26,900	7,900	-	-	6	4,112	6,986
6	CEL0310*S6E^A	LSF280	31,400	9,200	-	-	6	3,843	6,529
4	CEL0045*S4E^A	LFF041	4,500	1,300	-	-	1	667	1,132
4	CEL0070*S4E^A	LFF068	7,400	2,200	-	-	2	1,425	2,422
4	CEL0090*S4E^A	LFF080	8,800	2,600	-	-	2	1,332	2,263
4	CEL0135*S4E^A	LFF102	12,100	3,500	-	-	3	1,998	3,395
4	CEL0180*S4E^A	LFF136	16,300	4,700	-	-	4	2,664	4,527
4	CEL0220*S4E^A	LFF170	19,600	5,600	-	-	5	3,331	5,659
4	CEL0275*S4E^A	LFF204 LFF235	25,900	7,600	-	-	6	3,997	6,790

Notes:

¹ = Capacities shown are Application Capacities reflecting nominal operation at 10°F TD. For models within the scope of the DOE AWEF (Annual Walk-in Energy Factor) standard, the Net Capacity is determined by the AHRI 1250 test method. DOE will publish this compliance data at www.regulations.doe.gov

* = Electrical Code Designator (see Nomenclature details)

^ = Motor Code Designator (see Nomenclature details)

Net Capacity is available upon request

PERFORMANCE DATA

Application Capacity: Low Temperature Electric Defrost- 60 Hz

Please consult AWEF table on pages 44 & 45 to confirm model meets DOE minimum AWEF

Please refer to Table 1: Capacity Correction Factors (page 6) if using Saturated Suction Temperatures different than listed in the information below

FPI	New Model	Legacy Model	CO ₂ DX		Fan Data		
			Application Capacity ¹				
			10°F TD/-20°F SST	6°C TD/-29°C SST	No. of Fans	CFM	m ³ H
			BTUH	Watts			
6	CEL0040*C6E^A	N/A	3,900	1,143	1	685	1,164
6	CEL0045*C6E^A	N/A	5,300	1,553	1	641	1,088
6	CEL0065*C6E^A	N/A	7,200	2,110	2	1,371	2,329
6	CEL0080*C6E^A	N/A	8,400	2,462	2	1,371	2,329
6	CEL0100*C6E^A	N/A	9,900	2,901	2	1,281	2,176
6	CEL0130*C6E^A	N/A	13,500	3,956	3	2,056	3,493
6	CEL0155*C6E^A	N/A	16,000	4,689	3	1,922	3,265
6	CEL0170*C6E^A	N/A	17,900	5,246	4	2,741	4,657
6	CEL0205*C6E^A	N/A	20,100	5,891	4	2,562	4,353
6	CEL0240*C6E^A	N/A	22,400	6,565	5	3,203	5,441
6	CEL0255*C6E^A	N/A	26,900	7,884	6	4,112	6,986
6	CEL0310*C6E^A	N/A	31,400	9,202	6	3,843	6,529
4	CEL0045*C4E^A	N/A	4,500	1,319	1	667	1,132
4	CEL0070*C4E^A	N/A	7,400	2,169	2	1,425	2,422
4	CEL0090*C4E^A	N/A	8,800	2,579	2	1,332	2,263
4	CEL0135*C4E^A	N/A	12,100	3,546	3	1,998	3,395
4	CEL0180*C4E^A	N/A	16,300	4,777	4	2,664	4,527
4	CEL0220*C4E^A	N/A	19,600	5,744	5	3,331	5,659
4	CEL0275*C4E^A	N/A	25,900	7,591	6	3,997	6,790

Notes:
¹ = Capacities shown are Application Capacities reflecting nominal operation at 10°F TD. For models within the scope of the DOE AWEF (Annual Walk-in Energy Factor) standard, the Net Capacity is determined by the AHRI 1250 test method. DOE will publish this compliance data at www.regulations.doe.gov
 * = Electrical Code Designator (see Nomenclature details)
 ^ = Motor Code Designator (see Nomenclature details)
 Net Capacity is available upon request

PERFORMANCE DATA

Application Capacity: Low Temperature Electric Defrost- 50 Hz (For PSC Motors)[†]

Please consult AWEF table on pages 44 & 45 to confirm model meets DOE minimum AWEF

Please refer to Table 1: Capacity Correction Factors (page 6) if using Saturated Suction Temperatures different than listed in the information below

FPI	New Model	Legacy Model	R-404A/R-507A		R-448A/R-449A		Fan Data		
			Application Capacity ¹		Application Capacity ¹				
			10°F TD/-20°F SST	6°C TD/-29°C SST	10°F TD/-20°F SST	6°C TD/-29°C SST	No. of Fans	CFM	m ³ H
			BTUH	Watts	BTUH	Watts			
6	CEL0040*S6E^A	LSF035 LSF040	3,325	950	3,705	950	1	617	1,048
6	CEL0045*S6E^A	LSF040 LSF047	4,465	1,330	5,035	1,520	1	576	979
6	CEL0065*S6E^A	LSF065	6,175	1,805	6,840	1,995	2	1,234	2,096
6	CEL0080*S6E^A	LSF075	7,125	2,090	7,980	2,375	2	1,234	2,096
6	CEL0100*S6E^A	LSF090	8,550	2,470	9,405	2,755	2	1,153	1,959
6	CEL0130*S6E^A	LSF120	11,400	3,325	12,825	3,800	3	1,850	3,144
6	CEL0155*S6E^A	LSF140	13,300	3,895	15,200	4,465	3	1,729	2,938
6	CEL0170*S6E^A	LSF160	15,200	4,465	17,005	4,940	4	2,467	4,192
6	CEL0205*S6E^A	LSF180	17,100	5,035	19,095	5,605	4	2,306	3,918
6	CEL0240*S6E^A	LSF200	19,000	5,605	21,660	6,270	5	2,882	4,897
6	CEL0255*S6E^A	LSF240	22,800	6,650	25,555	7,505	6	3,701	6,288
6	CEL0310*S6E^A	LSF280	26,600	7,790	29,830	8,740	6	2,459	5,876
4	CEL0045*S4E^A	LFF041	3,895	1,140	4,275	1,235	1	600	1,019
4	CEL0070*S4E^A	LFF068	6,460	1,900	7,030	2,090	2	1,283	2,180
4	CEL0090*S4E^A	LFF080	7,600	2,185	8,360	2,470	2	1,199	2,037
4	CEL0135*S4E^A	LFF102	9,690	2,850	12,160	3,515	3	1,799	3,056
4	CEL0180*S4E^A	LFF136	12,920	3,800	16,435	4,750	4	2,398	4,074
4	CEL0220*S4E^A	LFF170	16,150	4,750	18,525	5,320	5	2,998	5,093
4	CEL0275*S4E^A	LFF204 LFF235	22,325	6,555	24,605	7,220	6	3,597	6,111

Notes:

¹ = Capacities shown are Application Capacities reflecting nominal operation at 10°F TD. For models within the scope of the DOE AWEF (Annual Walk-in Energy Factor) standard, the Net Capacity is determined by the AHRI 1250 test method. DOE will publish this compliance data at www.regulations.doe.gov

* = Electrical Code Designator (see Nomenclature details)

^ = Motor Code Designator (see Nomenclature details)

Net Capacity is available upon request

[†] = For 1-speed and 2-speed EC motors, use 60 Hz capacity and airflow values. (units with EC motors operating at 50 Hz will not see a reduction in performance due to the electronic control of the motor)

PERFORMANCE DATA

Application Capacity: Low Temperature Electric Defrost- 50 Hz (For PSC Motors) †

Please consult AWEF table on pages 44 & 45 to confirm model meets DOE minimum AWEF

Please refer to Table 1: Capacity Correction Factors (page 6) if using Saturated Suction Temperatures different than listed in the information below

FPI	New Model	Legacy Model	R-407A/R-407F		R-407C		Fan Data		
			Application Capacity ¹		Application Capacity ¹				
			10°F TD/-20°F SST	6°C TD/-29°C SST	10°F TD/-20°F SST	6°C TD/-29°C SST	No. of Fans	CFM	m ³ H
			BTUH	Watts	BTUH	Watts			
6	CEL0040*S6E^A	N/A	3,705	950	-	-	1	617	1,048
6	CEL0045*S6E^A	N/A	5,035	1,520	-	-	1	576	979
6	CEL0065*S6E^A	N/A	6,840	1,995	-	-	2	1,234	2,096
6	CEL0080*S6E^A	N/A	7,980	2,375	-	-	2	1,234	2,096
6	CEL0100*S6E^A	N/A	9,405	2,755	-	-	2	1,153	1,959
6	CEL0130*S6E^A	N/A	12,825	3,800	-	-	3	1,850	3,144
6	CEL0155*S6E^A	N/A	15,200	4,465	-	-	3	1,729	2,938
6	CEL0170*S6E^A	N/A	17,005	4,940	-	-	4	2,467	4,192
6	CEL0205*S6E^A	N/A	19,095	5,605	-	-	4	2,306	3,918
6	CEL0240*S6E^A	N/A	21,280	6,175	-	-	5	2,882	4,897
6	CEL0255*S6E^A	N/A	25,555	7,505	-	-	6	3,701	6,288
6	CEL0310*S6E^A	N/A	29,830	8,740	-	-	6	2,459	5,876
4	CEL0045*S4E^A	N/A	4,275	1,235	-	-	1	600	1,019
4	CEL0070*S4E^A	N/A	7,030	2,090	-	-	2	1,283	2,180
4	CEL0090*S4E^A	N/A	8,360	2,470	-	-	2	1,199	2,037
4	CEL0135*S4E^A	N/A	11,495	3,325	-	-	3	1,799	3,056
4	CEL0180*S4E^A	N/A	15,485	4,465	-	-	4	2,398	4,074
4	CEL0220*S4E^A	N/A	18,620	5,320	-	-	5	2,998	5,093
4	CEL0275*S4E^A	N/A	24,605	7,220	-	-	6	3,597	6,111

Notes:

¹ = Capacities shown are Application Capacities reflecting nominal operation at 10°F TD. For models within the scope of the DOE AWEF (Annual Walk-in Energy Factor) standard, the Net Capacity is determined by the AHRI 1250 test method. DOE will publish this compliance data at www.regulations.doe.gov

* = Electrical Code Designator (see Nomenclature details)

^ = Motor Code Designator (see Nomenclature details)

Net Capacity is available upon request

† = For 1-speed and 2-speed EC motors, use 60 Hz capacity and airflow values. (units with EC motors operating at 50 Hz will not see a reduction in performance due to the electronic control of the motor)

PERFORMANCE DATA

Application Capacity: Low Temperature Electric Defrost- 50 Hz (For PSC Motors) †

Please consult AWEF table on pages 44 & 45 to confirm model meets DOE minimum AWEF

Please refer to Table 1: Capacity Correction Factors (page 6) if using Saturated Suction Temperatures different than listed in the information below

FPI	New Model	Legacy Model	CO ₂ DX		Fan Data		
			Application Capacity ¹				
			10°F TD/-20°F SST	6°C TD/-29°C SST	No. of Fans	CFM	m ³ H
			BTUH	Watts			
6	CEL0040*C6E^A	N/A	3,705	1,086	1	617	1,048
6	CEL0045*C6E^A	N/A	5,035	1,476	1	576	979
6	CEL0065*C6E^A	N/A	6,840	2,005	2	1,234	2,096
6	CEL0080*C6E^A	N/A	7,980	2,339	2	1,234	2,096
6	CEL0100*C6E^A	N/A	9,405	2,756	2	1,153	1,959
6	CEL0130*C6E^A	N/A	12,825	3,759	3	1,850	3,144
6	CEL0155*C6E^A	N/A	15,200	4,455	3	1,729	2,938
6	CEL0170*C6E^A	N/A	17,005	4,984	4	2,467	4,192
6	CEL0205*C6E^A	N/A	19,095	5,596	4	2,306	3,918
6	CEL0240*C6E^A	N/A	21,280	6,237	5	2,882	4,897
6	CEL0255*C6E^A	N/A	25,555	7,489	6	3,701	6,288
6	CEL0310*C6E^A	N/A	29,830	8,742	6	2,459	5,876
4	CEL0045*C4E^A	N/A	4,275	1,253	1	600	1,019
4	CEL0070*C4E^A	N/A	7,030	2,060	2	1,283	2,180
4	CEL0090*C4E^A	N/A	8,360	2,450	2	1,199	2,037
4	CEL0135*C4E^A	N/A	11,495	3,369	3	1,799	3,056
4	CEL0180*C4E^A	N/A	15,485	4,538	4	2,398	4,074
4	CEL0220*C4E^A	N/A	18,620	5,457	5	2,998	5,093
4	CEL0275*C4E^A	N/A	24,605	7,211	6	3,597	6,111

Notes:

¹ = Capacities shown are Application Capacities reflecting nominal operation at 10°F TD. For models within the scope of the DOE AWEF (Annual Walk-in Energy Factor) standard, the Net Capacity is determined by the AHRI 1250 test method. DOE will publish this compliance data at www.regulations.doe.gov

* = Electrical Code Designator (see Nomenclature details)

^ = Motor Code Designator (see Nomenclature details)

Net Capacity is available upon request

† = For 1-speed and 2-speed EC motors, use 60 Hz capacity and airflow values. (units with EC motors operating at 50 Hz will not see a reduction in performance due to the electronic control of the motor)

PERFORMANCE DATA

Application Capacity: Medium Temperature Electric Defrost- 60 Hz

Please consult AWEF table on pages 44 & 45 to confirm model meets DOE minimum AWEF

Please refer to Table 1: Capacity Correction Factors (page 6) if using Saturated Suction Temperatures different than listed in the information below

FPI	New Model	Legacy Model	R-404A/R-507A		R-448A/R-449A		Fan Data		
			Application Capacity ¹		Application Capacity ¹				
			10°F TD/25°F SST	6°C TD/-4°F SST	10°F TD/25°F SST	6°C TD/-4°F SST	No. of Fans	CFM	m ³ H
			BTUH	Watts	BTUH	Watts			
6	CEL0040*S6E^A	LSF035 LSF040	4,000	1,200	4,500	1,300	1	685	1,164
6	CEL0045*S6E^A	LSF040 LSF047	5,400	1,550	6,100	1,750	1	641	1,088
6	CEL0065*S6E^A	LSF065	7,450	2,150	8,300	2,400	2	1,371	2,329
6	CEL0080*S6E^A	LSF075	8,650	2,500	9,650	2,800	2	1,371	2,329
6	CEL0100*S6E^A	LSF090	10,350	3,000	11,400	3,300	2	1,281	2,176
6	CEL0130*S6E^A	LSF120	13,800	4,000	15,500	4,500	3	2,056	3,493
6	CEL0155*S6E^A	LSF140	16,100	4,650	18,400	5,300	3	1,922	3,265
6	CEL0170*S6E^A	LSF160	18,400	5,300	20,600	5,950	4	2,741	4,658
6	CEL0205*S6E^A	LSF180	20,700	6,000	23,100	6,650	4	2,562	4,353
6	CEL0240*S6E^A	LSF200	23,000	6,650	25,750	7,450	5	3,203	5,441
6	CEL0255*S6E^A	LSF240	27,600	7,950	30,950	8,950	6	4,112	6,986
6	CEL0310*S6E^A	LSF280	32,200	9,300	36,100	10,400	6	3,843	6,529
4	CEL0045*S4E^A	LFF041	4,700	1,400	5,200	1,500	1	667	1,132
4	CEL0070*S4E^A	LFF068	7,800	2,250	8,500	2,450	2	1,425	2,422
4	CEL0090*S4E^A	LFF080	9,200	2,650	10,100	2,900	2	1,332	2,263
4	CEL0135*S4E^A	LFF102	11,750	3,400	13,050	3,800	3	1,998	3,395
4	CEL0180*S4E^A	LFF136	15,650	4,500	17,650	5,100	4	2,664	4,527
4	CEL0220*S4E^A	LFF170	19,550	5,650	21,850	6,300	5	3,331	5,659
4	CEL0275*S4E^A	LFF204 LFF235	27,000	7,800	29,800	8,600	6	3,997	6,790

Notes:

¹ = Capacities shown are Application Capacities reflecting nominal operation at 10°F TD. For models within the scope of the DOE AWEF (Annual Walk-in Energy Factor) standard, the Net Capacity is determined by the AHRI 1250 test method. DOE will publish this compliance data at www.regulations.doe.gov

* = Electrical Code Designator (see Nomenclature details)

^ = Motor Code Designator (see Nomenclature details)

Net Capacity is available upon request

PERFORMANCE DATA

Application Capacity: Medium Temperature Electric Defrost- 60 Hz

Please consult AWEF table on pages 44 & 45 to confirm model meets DOE minimum AWEF

Please refer to Table 1: Capacity Correction Factors (page 6) if using Saturated Suction Temperatures different than listed in the information below

FPI	New Model	Legacy Model	R-407A/R-407F		R-407C		Fan Data		
			Application Capacity ¹		Application Capacity ¹				
			10°F TD/25°F SST	6°C TD/-4°F SST	10°F TD/25°F SST	6°C TD/-4°F SST	No. of Fans	CFM	m ³ H
			BTUH	Watts	BTUH	Watts			
6	CEL0040*S6E^A	LSF035 LSF040	4,500	1,300	-	-	1	685	1,164
6	CEL0045*S6E^A	LSF040 LSF047	6,100	1,750	-	-	1	641	1,088
6	CEL0065*S6E^A	LSF065	8,300	2,400	-	-	2	1,371	2,329
6	CEL0080*S6E^A	LSF075	9,650	2,800	-	-	2	1,371	2,329
6	CEL0100*S6E^A	LSF090	11,400	3,300	-	-	2	1,281	2,176
6	CEL0130*S6E^A	LSF120	15,500	4,500	-	-	3	2,056	3,493
6	CEL0155*S6E^A	LSF140	18,400	5,300	-	-	3	1,922	3,265
6	CEL0170*S6E^A	LSF160	20,600	5,950	-	-	4	2,741	4,658
6	CEL0205*S6E^A	LSF180	23,100	6,650	-	-	4	2,562	4,353
6	CEL0240*S6E^A	LSF200	25,750	7,450	-	-	5	3,203	5,441
6	CEL0255*S6E^A	LSF240	30,950	8,950	-	-	6	4,112	6,986
6	CEL0310*S6E^A	LSF280	36,100	10,400	-	-	6	3,843	6,529
4	CEL0045*S4E^A	LFF041	5,200	1,500	-	-	1	667	1,132
4	CEL0070*S4E^A	LFF068	8,500	2,450	-	-	2	1,425	2,422
4	CEL0090*S4E^A	LFF080	10,100	2,900	-	-	2	1,332	2,263
4	CEL0135*S4E^A	LFF102	13,050	3,800	-	-	3	1,998	3,395
4	CEL0180*S4E^A	LFF136	17,650	5,100	-	-	4	2,664	4,527
4	CEL0220*S4E^A	LFF170	21,850	6,300	-	-	5	3,331	5,659
4	CEL0275*S4E^A	LFF204 LFF235	29,800	8,600	-	-	6	3,997	6,790

Notes:

¹ = Capacities shown are Application Capacities reflecting nominal operation at 10°F TD. For models within the scope of the DOE AWEF (Annual Walk-in Energy Factor) standard, the Net Capacity is determined by the AHRI 1250 test method. DOE will publish this compliance data at www.regulations.doe.gov

* = Electrical Code Designator (see Nomenclature details)

^ = Motor Code Designator (see Nomenclature details)

Net Capacity is available upon request

PERFORMANCE DATA

Application Capacity: Medium Temperature Electric Defrost- 60 Hz

Please consult AWEF table on pages 44 & 45 to confirm model meets DOE minimum AWEF

Please refer to Table 1: Capacity Correction Factors (page 6) if using Saturated Suction Temperatures different than listed in the information below

		CO ₂ DX					
		Legacy Model	Application Capacity ¹		Fan Data		
			10°F TD/-20°F SST	6°C TD/-29°C SST			
FPI	New Model		BTUH	Watts	No. of Fans	CFM	m ³ H
6	CEL0040*C6E^A	N/A	4,500	1,319	1	685	1,164
6	CEL0045*C6E^A	N/A	6,100	1,788	1	641	1,089
6	CEL0065*C6E^A	N/A	8,300	2,432	2	1,371	2,329
6	CEL0080*C6E^A	N/A	9,650	2,828	2	1,371	2,329
6	CEL0100*C6E^A	N/A	11,400	3,341	2	1,281	2,176
6	CEL0130*C6E^A	N/A	15,500	4,543	3	2,056	3,493
6	CEL0155*C6E^A	N/A	18,400	5,393	3	1,922	3,265
6	CEL0170*C6E^A	N/A	20,600	6,037	4	2,741	4,657
6	CEL0205*C6E^A	N/A	23,100	6,770	4	2,562	4,353
6	CEL0240*C6E^A	N/A	25,750	7,547	5	3,203	5,442
6	CEL0255*C6E^A	N/A	30,950	9,071	6	4,112	6,986
6	CEL0310*C6E^A	N/A	36,100	10,580	6	3,843	6,529
4	CEL0045*C4E^A	N/A	5,200	1,524	1	641	1,089
4	CEL0070*C4E^A	N/A	8,500	2,491	2	1,425	2,421
4	CEL0090*C4E^A	N/A	10,100	2,960	2	1,332	2,263
4	CEL0135*C4E^A	N/A	13,050	3,825	3	1,998	3,395
4	CEL0180*C4E^A	N/A	17,650	5,173	4	2,664	4,526
4	CEL0220*C4E^A	N/A	21,850	6,404	5	3,331	5,659
4	CEL0275*C4E^A	N/A	29,800	8,734	6	3,997	6,791

Notes:
¹ = Capacities shown are Application Capacities reflecting nominal operation at 10°F TD. For models within the scope of the DOE AWEF (Annual Walk-in Energy Factor) standard, the Net Capacity is determined by the AHRI 1250 test method. DOE will publish this compliance data at www.regulations.doe.gov
 * = Electrical Code Designator (see Nomenclature details)
 ^ = Motor Code Designator (see Nomenclature details)
 Net Capacity is available upon request

SPECIFICATIONS

Electric Defrost- 60 Hz

Please consult AWEF table on pages 44 & 45 to confirm model meets DOE minimum AWEF

FPI	New Model	HP	2-Speed EC Motor (Totally Enclosed)				Defrost Heaters-230V			Defrost Heaters-460V	
			208-230/1/60				Watts	230/1/60	230/3/60	Watts	460/1/60
			Amps	Watts	MCA	MOPD					
6	CEL0040*±6EMA	1/20	0.5	55	0.6	15	1,050	4.6	2.8	900	2.0
6	CEL0045*±6EMA	1/20	0.5	55	0.6	15	1,050	4.6	2.8	900	2.0
6	CEL0065*±6EMA	1/20	1.0	110	1.1	15	2,100	9.1	5.7	1,800	3.9
6	CEL0080*±6EMA	1/20	1.0	110	1.1	15	2,100	9.1	5.7	1,800	3.9
6	CEL0100*±6EMA	1/20	1.0	110	1.1	15	2,100	9.1	5.7	1,800	3.9
6	CEL0130*±6EMA	1/20	1.5	165	1.6	15	3,150	13.7	8.5	2,700	5.9
6	CEL0155*±6EMA	1/20	1.5	165	1.6	15	3,150	13.7	8.5	2,700	5.9
6	CEL0170*±6EMA	1/20	2.0	220	2.1	15	4,200	18.3	11.4	3,600	7.8
6	CEL0205*±6EMA	1/20	2.0	220	2.1	15	4,200	18.3	11.4	3,600	7.8
6	CEL0240*±6EMA	1/20	2.5	275	2.6	15	5,250	22.8	14.2	4,500	9.8
6	CEL0255*±6EMA	1/20	3.0	330	3.1	15	6,300	27.4	17.1	5,400	11.7
6	CEL0310*±6EMA	1/20	3.0	330	3.1	15	6,300	27.4	17.1	5,400	11.7
4	CEL0045*±4EMA	1/20	0.5	55	0.6	15	1,050	4.6	2.8	900	2.0
4	CEL0070*±4EMA	1/20	1.0	110	1.1	15	2,100	9.1	5.7	1,800	3.9
4	CEL0090*±4EMA	1/20	1.0	110	1.1	15	2,100	9.1	5.7	1,800	3.9
4	CEL0135*±4EMA	1/20	1.5	165	1.6	15	3,150	13.7	8.5	2,700	5.9
4	CEL0180*±4EMA	1/20	2.0	220	2.1	15	4,200	18.3	11.4	3,600	7.8
4	CEL0220*±4EMA	1/20	2.5	275	2.6	15	5,250	22.8	14.2	4,500	9.8
4	CEL0275*±4EMA	1/20	3.0	330	3.1	15	6,300	27.4	17.1	5,400	11.7

FPI	New Model	HP	1-Speed EC Motor (Totally Enclosed)				Defrost Heaters-230V			Defrost Heaters-460V	
			208-230/1/60				Watts	230/1/60	230/3/60	Watts	460/1/60
			Amps	Watts	MCA	MOPD					
6	CEL0040*±6EEA	1/20	0.5	59	0.6	15	1,050	4.6	2.8	900	2.0
6	CEL0045*±6EEA	1/20	0.5	59	0.6	15	1,050	4.6	2.8	900	2.0
6	CEL0065*±6EEA	1/20	1.0	118	1.1	15	2,100	9.1	5.7	1,800	3.9
6	CEL0080*±6EEA	1/20	1.0	118	1.1	15	2,100	9.1	5.7	1,800	3.9
6	CEL0100*±6EEA	1/20	1.0	118	1.1	15	2,100	9.1	5.7	1,800	3.9
6	CEL0130*±6EEA	1/20	1.5	177	1.6	15	3,150	13.7	8.5	2,700	5.9
6	CEL0155*±6EEA	1/20	1.5	177	1.6	15	3,150	13.7	8.5	2,700	5.9
6	CEL0170*±6EEA	1/20	2.0	236	2.1	15	4,200	18.3	11.4	3,600	7.8
6	CEL0205*±6EEA	1/20	2.0	236	2.1	15	4,200	18.3	11.4	3,600	7.8
6	CEL0240*±6EEA	1/20	2.5	295	2.6	15	5,250	22.8	14.2	4,500	9.8
6	CEL0255*±6EEA	1/20	3.0	354	3.1	15	6,300	27.4	17.1	5,400	11.7
6	CEL0310*±6EEA	1/20	3.0	354	3.1	15	6,300	27.4	17.1	5,400	11.7
4	CEL0045*±4EEA	1/20	0.5	59	0.6	15	1,050	4.6	2.8	900	2.0
4	CEL0070*±4EEA	1/20	1.0	118	1.1	15	2,100	9.1	5.7	1,800	3.9
4	CEL0090*±4EEA	1/20	1.0	118	1.1	15	2,100	9.1	5.7	1,800	3.9
4	CEL0135*±4EEA	1/20	1.5	177	1.6	15	3,150	13.7	8.5	2,700	5.9
4	CEL0180*±4EEA	1/20	2.0	236	2.1	15	4,200	18.3	11.4	3,600	7.8
4	CEL0220*±4EEA	1/20	2.5	295	2.6	15	5,250	22.8	14.2	4,500	9.8
4	CEL0275*±4EEA	1/20	3.0	354	3.1	15	6,300	27.4	17.1	5,400	11.7

Notes:

* = Electrical Code Designator (see Nomenclature details)
 ± = Refrigerant Designator (see Nomenclature details)

SPECIFICATIONS

Electric Defrost- 60 Hz

Please consult AWEF table on pages 44 & 45 to confirm model meets DOE minimum AWEF

FPI	New Model	HP	PSC Motor (Totally Enclosed)				Defrost Heaters-230V			Defrost Heaters-460V	
			208-230/1/60				Watts	230/1/60	230/3/60	Watts	460/1/60
			Amps	Watts	MCA	MOPD					
6	CEL0040*±6ECA	1/20	0.5	91	0.6	15	1,050	4.6	2.8	900	2.0
6	CEL0045*±6ECA	1/20	0.5	91	0.6	15	1,050	4.6	2.8	900	2.0
6	CEL0065*±6ECA	1/20	1.0	182	1.1	15	2,100	9.1	5.7	1,800	3.9
6	CEL0080*±6ECA	1/20	1.0	182	1.1	15	2,100	9.1	5.7	1,800	3.9
6	CEL0100*±6ECA	1/20	1.0	182	1.1	15	2,100	9.1	5.7	1,800	3.9
6	CEL0130*±6ECA	1/20	1.5	273	1.6	15	3,150	13.7	8.5	2,700	5.9
6	CEL0155*±6ECA	1/20	1.5	273	1.6	15	3,150	13.7	8.5	2,700	5.9
6	CEL0170*±6ECA	1/20	2.0	364	2.1	15	4,200	18.3	11.4	3,600	7.8
6	CEL0205*±6ECA	1/20	2.0	364	2.1	15	4,200	18.3	11.4	3,600	7.8
6	CEL0240*±6ECA	1/20	2.5	455	2.6	15	5,250	22.8	14.2	4,500	9.8
6	CEL0255*±6ECA	1/20	3.0	546	3.1	15	6,300	27.4	17.1	5,400	11.7
6	CEL0310*±6ECA	1/20	3.0	546	3.1	15	6,300	27.4	17.1	5,400	11.7
4	CEL0045*±4ECA	1/20	0.5	91	0.6	15	1,050	4.6	2.8	900	2.0
4	CEL0070*±4ECA	1/20	1.0	182	1.1	15	2,100	9.1	5.7	1,800	3.9
4	CEL0090*±4ECA	1/20	1.0	182	1.1	15	2,100	9.1	5.7	1,800	3.9
4	CEL0135*±4ECA	1/20	1.5	273	1.6	15	3,150	13.7	8.5	2,700	5.9
4	CEL0180*±4ECA	1/20	2.0	364	2.1	15	4,200	18.3	11.4	3,600	7.8
4	CEL0220*±4ECA	1/20	2.5	455	2.6	15	5,250	22.8	14.2	4,500	9.8
4	CEL0275*±4ECA	1/20	3.0	546	3.1	15	6,300	27.4	17.1	5,400	11.7

FPI	New Model	HP	PSC Motor (Totally Enclosed)				Defrost Heaters-230V			Defrost Heaters-460V	
			460/1/60				Watts	230/1/60	230/3/60	Watts	460/1/60
			Amps	Watts	MCA	MOPD					
6	CEL0040*±6ECA	1/20	0.4	117	0.5	15	1,050	4.6	2.8	900	2.0
6	CEL0045*±6ECA	1/20	0.4	117	0.5	15	1,050	4.6	2.8	900	2.0
6	CEL0065*±6ECA	1/20	0.8	234	0.9	15	2,100	9.1	5.7	1,800	3.9
6	CEL0080*±6ECA	1/20	0.8	234	0.9	15	2,100	9.1	5.7	1,800	3.9
6	CEL0100*±6ECA	1/20	0.8	234	0.9	15	2,100	9.1	5.7	1,800	3.9
6	CEL0130*±6ECA	1/20	1.2	351	1.3	15	3,150	13.7	8.5	2,700	5.9
6	CEL0155*±6ECA	1/20	1.2	351	1.3	15	3,150	13.7	8.5	2,700	5.9
6	CEL0170*±6ECA	1/20	1.6	468	1.7	15	4,200	18.3	11.4	3,600	7.8
6	CEL0205*±6ECA	1/20	1.6	468	1.7	15	4,200	18.3	11.4	3,600	7.8
6	CEL0240*±6ECA	1/20	2.0	585	2.1	15	5,250	22.8	14.2	4,500	9.8
6	CEL0255*±6ECA	1/20	2.4	702	2.5	15	6,300	27.4	17.1	5,400	11.7
6	CEL0310*±6ECA	1/20	2.4	702	2.5	15	6,300	27.4	17.1	5,400	11.7
4	CEL0045*±4ECA	1/20	0.4	117	0.5	15	1,050	4.6	2.8	900	2.0
4	CEL0070*±4ECA	1/20	0.8	234	0.9	15	2,100	9.1	5.7	1,800	3.9
4	CEL0090*±4ECA	1/20	0.8	234	0.9	15	2,100	9.1	5.7	1,800	3.9
4	CEL0135*±4ECA	1/20	1.2	351	1.3	15	3,150	13.7	8.5	2,700	5.9
4	CEL0180*±4ECA	1/20	1.6	468	1.7	15	4,200	18.3	11.4	3,600	7.8
4	CEL0220*±4ECA	1/20	2.0	585	2.1	15	5,250	22.8	14.2	4,500	9.8
4	CEL0275*±4ECA	1/20	2.4	702	2.5	15	6,300	27.4	17.1	5,400	11.7

Notes:
 * = Electrical Code Designator (see Nomenclature details)
 ± = Refrigerant Designator (see Nomenclature details)

SPECIFICATIONS

Electric Defrost- 50 Hz

Please consult AWEF table on pages 44 & 45 to confirm model meets DOE minimum AWEF

FPI	New Model	HP	2-Speed EC Motor (Totally Enclosed)				Defrost Heaters	
			220/1/50				Watts	220/1/50 Total Amps
			Amps	Watts	MCA	MOPD		
6	CEL0040*±6EMA	1/20	0.5	55	0.6	15	960	4.4
6	CEL0045*±6EMA	1/20	0.5	55	0.6	15	960	4.4
6	CEL0065*±6EMA	1/20	1.0	110	1.1	15	1,920	8.7
6	CEL0080*±6EMA	1/20	1.0	110	1.1	15	1,920	8.7
6	CEL0100*±6EMA	1/20	1.0	110	1.1	15	1,920	8.7
6	CEL0130*±6EMA	1/20	1.5	165	1.6	15	2,880	13.1
6	CEL0155*±6EMA	1/20	1.5	165	1.6	15	2,880	13.1
6	CEL0170*±6EMA	1/20	2.0	220	2.1	15	3,845	17.5
6	CEL0205*±6EMA	1/20	2.0	220	2.1	15	3,845	17.5
6	CEL0240*±6EMA	1/20	2.5	275	2.6	15	4,805	21.8
6	CEL0255*±6EMA	1/20	3.0	330	3.1	15	5,765	26.2
6	CEL0310*±6EMA	1/20	3.0	330	3.1	15	5,765	26.2
4	CEL0045*±4EMA	1/20	0.5	55	0.6	15	960	4.4
4	CEL0070*±4EMA	1/20	1.0	110	1.1	15	1,920	8.7
4	CEL0090*±4EMA	1/20	1.0	110	1.1	15	1,920	8.7
4	CEL0135*±4EMA	1/20	1.5	165	1.6	15	2,880	13.1
4	CEL0180*±4EMA	1/20	2.0	220	2.1	15	3,845	17.5
4	CEL0220*±4EMA	1/20	2.5	275	2.6	15	4,805	21.8
4	CEL0275*±4EMA	1/20	3.0	330	3.1	15	5,765	26.2

FPI	New Model	HP	1-Speed EC Motor (Totally Enclosed)				Defrost Heaters	
			220/1/50				Watts	220/1/50 Total Amps
			Amps	Watts	MCA	MOPD		
6	CEL0040*±6EEA	1/20	0.5	59	0.6	15	960	4.4
6	CEL0045*±6EEA	1/20	0.5	59	0.6	15	960	4.4
6	CEL0065*±6EEA	1/20	1.0	118	1.1	15	1,920	8.7
6	CEL0080*±6EEA	1/20	1.0	118	1.1	15	1,920	8.7
6	CEL0100*±6EEA	1/20	1.0	118	1.1	15	1,920	8.7
6	CEL0130*±6EEA	1/20	1.5	177	1.6	15	2,880	13.1
6	CEL0155*±6EEA	1/20	1.5	177	1.6	15	2,880	13.1
6	CEL0170*±6EEA	1/20	2.0	236	2.1	15	3,845	17.5
6	CEL0205*±6EEA	1/20	2.0	236	2.1	15	3,845	17.5
6	CEL0240*±6EEA	1/20	2.5	295	2.6	15	4,805	21.8
6	CEL0255*±6EEA	1/20	3.0	354	3.1	15	5,765	26.2
6	CEL0310*±6EEA	1/20	3.0	354	3.1	15	5,765	26.2
4	CEL0045*±4EEA	1/20	0.5	59	0.6	15	960	4.4
4	CEL0070*±4EEA	1/20	1.0	118	1.1	15	1,920	8.7
4	CEL0090*±4EEA	1/20	1.0	118	1.1	15	1,920	8.7
4	CEL0135*±4EEA	1/20	1.5	177	1.6	15	2,880	13.1
4	CEL0180*±4EEA	1/20	2.0	236	2.1	15	3,845	17.5
4	CEL0220*±4EEA	1/20	2.5	295	2.6	15	4,805	21.8
4	CEL0275*±4EEA	1/20	3.0	354	3.1	15	5,765	26.2

Notes:

* = Electrical Code Designator (see Nomenclature details)

± = Refrigerant Designator (see Nomenclature details)

SPECIFICATIONS

Electric Defrost- 50 Hz

Please consult AWEF table on pages 44 & 45 to confirm model meets DOE minimum AWEF

FPI	New Model	HP	PSC Motor (Totally Enclosed)				Defrost Heaters	
			220/1/50				Watts	220/1/50 Total Amps
			Amps	Watts	MCA	MOPD		
6	CEL0040*±6ECA	1/20	0.5	65	0.6	15	960	4.4
6	CEL0045*±6ECA	1/20	0.5	65	0.6	15	960	4.4
6	CEL0065*±6ECA	1/20	1.0	130	1.1	15	1,920	8.7
6	CEL0080*±6ECA	1/20	1.0	130	1.1	15	1,920	8.7
6	CEL0100*±6ECA	1/20	1.0	130	1.1	15	1,920	8.7
6	CEL0130*±6ECA	1/20	1.5	195	1.6	15	2,880	13.1
6	CEL0155*±6ECA	1/20	1.5	195	1.6	15	2,880	13.1
6	CEL0170*±6ECA	1/20	2.0	260	2.1	15	3,845	17.5
6	CEL0205*±6ECA	1/20	2.0	260	2.1	15	3,845	17.5
6	CEL0240*±6ECA	1/20	2.5	325	2.6	15	4,805	21.8
6	CEL0255*±6ECA	1/20	3.0	390	3.1	15	5,765	26.2
6	CEL0310*±6ECA	1/20	3.0	390	3.1	15	5,765	26.2
4	CEL0045*±4ECA	1/20	0.5	65	0.6	15	960	4.4
4	CEL0070*±4ECA	1/20	1.0	130	1.1	15	1,920	8.7
4	CEL0090*±4ECA	1/20	1.0	130	1.1	15	1,920	8.7
4	CEL0135*±4ECA	1/20	1.5	195	1.6	15	2,880	13.1
4	CEL0180*±4ECA	1/20	2.0	260	2.1	15	3,845	17.5
4	CEL0220*±4ECA	1/20	2.5	325	2.6	15	4,805	21.8
4	CEL0275*±4ECA	1/20	3.0	390	3.1	15	5,765	26.2

Notes:

* = Electrical Code Designator (see Nomenclature details)

± = Refrigerant Designator (see Nomenclature details)

PERFORMANCE DATA

Application Capacity: Low Temperature Hot Gas Defrost- 60 Hz

Please consult AWEF table on pages 46 & 47 to confirm model meets DOE minimum AWEF

Please refer to Table 1: Capacity Correction Factors (page 6) if using Saturated Suction Temperatures different than listed in the information below

FPI	New Model	Legacy Model	R-404A/R-507A		R-448A/R-449A		Fan Data		
			Application Capacity ¹		Application Capacity ¹				
			10°F TD/-20°F SST	6°C TD/-29°C SST	10°F TD/-20°F SST	6°C TD/-29°C SST	No. of Fans	CFM	m ³ H
			BTUH	Watts	BTUH	Watts			
6	CEL0040*S6H^A	LSH035 LSH040	3,500	1,000	3,900	1,000	1	685	1,164
6	CEL0045*S6H^A	LSH040 LSH047	4,700	1,400	5,300	1,600	1	641	1,088
6	CEL0065*S6H^A	LSH065	6,500	1,900	7,200	2,100	2	1,371	2,329
6	CEL0080*S6H^A	LSH075	7,500	2,200	8,400	2,500	2	1,371	2,329
6	CEL0100*S6H^A	LSH090	9,000	2,600	9,900	2,900	2	1,281	2,176
6	CEL0130*S6H^A	LSH120	12,000	3,500	13,500	4,000	3	2,056	3,493
6	CEL0155*S6H^A	LSH140	14,000	4,100	16,000	4,700	3	1,922	3,265
6	CEL0170*S6H^A	LSH160	16,000	4,700	17,900	5,200	4	2,741	4,658
6	CEL0205*S6H^A	LSH180	18,000	5,300	20,100	5,900	4	2,562	4,353
6	CEL0240*S6H^A	LSH200	20,000	5,900	22,800	6,600	5	3,203	5,441
6	CEL0255*S6H^A	LSH240	24,000	7,000	26,900	7,900	6	4,112	6,986
6	CEL0310*S6H^A	LSH280	28,000	8,200	31,400	9,200	6	3,843	6,529
4	CEL0045*S4H^A	LSH041	4,100	1,200	4,500	1,300	1	667	1,132
4	CEL0070*S4H^A	LSH068	6,800	2,000	7,400	2,200	2	1,425	2,422
4	CEL0090*S4H^A	LSH080	8,000	2,300	8,800	2,600	2	1,332	2,263
4	CEL0135*S4H^A	LSH102	10,200	3,000	12,800	3,700	3	1,998	3,395
4	CEL0180*S4H^A	LSH136	13,600	4,000	17,300	5,000	4	2,664	4,527
4	CEL0220*S4H^A	LSH170	17,000	5,000	19,500	5,600	5	3,331	5,659
4	CEL0275*S4H^A	LSH204 LSH235	23,500	6,900	25,900	7,600	6	3,997	6,790

Notes:

¹ = Capacities shown are Application Capacities reflecting nominal operation at 10°F TD. For models within the scope of the DOE AWEF (Annual Walk-in Energy Factor) standard, the Net Capacity is determined by the AHRI 1250 test method. DOE will publish this compliance data at www.regulations.doe.gov

* = Electrical Code Designator (see Nomenclature details)

^ = Motor Code Designator (see Nomenclature details)

Net Capacity is available upon request

PERFORMANCE DATA

Application Capacity: Low Temperature Hot Gas Defrost- 60 Hz

Please consult AWEF table on pages 46 & 47 to confirm model meets DOE minimum AWEF

Please refer to Table 1: Capacity Correction Factors (page 6) if using Saturated Suction Temperatures different than listed in the information below

FPI	New Model	Legacy Model	R-407A/R-407F		R-407C		Fan Data		
			Application Capacity ¹		Application Capacity ¹				
			10°F TD/-20°F SST	6°C TD/-29°C SST	10°F TD/-20°F SST	6°C TD/-29°C SST	No. of Fans	CFM	m ³ H
			BTUH	Watts	BTUH	Watts			
6	CEL0040*S6H^A	LSH035 LSH040	3,900	1,000	-	-	1	685	1,164
6	CEL0045*S6H^A	LSH040 LSH047	5,300	1,600	-	-	1	641	1,088
6	CEL0065*S6H^A	LSH065	7,200	2,100	-	-	2	1,371	2,329
6	CEL0080*S6H^A	LSH075	8,400	2,500	-	-	2	1,371	2,329
6	CEL0100*S6H^A	LSH090	9,900	2,900	-	-	2	1,281	2,176
6	CEL0130*S6H^A	LSH120	13,500	4,000	-	-	3	2,056	3,493
6	CEL0155*S6H^A	LSH140	16,000	4,700	-	-	3	1,922	3,265
6	CEL0170*S6H^A	LSH160	17,900	5,200	-	-	4	2,741	4,658
6	CEL0205*S6H^A	LSH180	20,100	5,900	-	-	4	2,562	4,353
6	CEL0240*S6H^A	LSH200	22,400	6,500	-	-	5	3,203	5,441
6	CEL0255*S6H^A	LSH240	26,900	7,900	-	-	6	4,112	6,986
6	CEL0310*S6H^A	LSH280	31,400	9,200	-	-	6	3,843	6,529
4	CEL0045*S4H^A	LSH041	4,500	1,300	-	-	1	667	1,132
4	CEL0070*S4H^A	LSH068	7,400	2,200	-	-	2	1,425	2,422
4	CEL0090*S4H^A	LSH080	8,800	2,600	-	-	2	1,332	2,263
4	CEL0135*S4H^A	LSH102	12,100	3,500	-	-	3	1,998	3,395
4	CEL0180*S4H^A	LSH136	16,300	4,700	-	-	4	2,664	4,527
4	CEL0220*S4H^A	LSH170	19,600	5,500	-	-	5	3,331	5,659
4	CEL0275*S4H^A	LSH204 LSH235	25,900	7,600	-	-	6	3,997	6,790

Notes:
¹ = Capacities shown are Application Capacities reflecting nominal operation at 10°F TD. For models within the scope of the DOE AWEF (Annual Walk-in Energy Factor) standard, the Net Capacity is determined by the AHRI 1250 test method. DOE will publish this compliance data at www.regulations.doe.gov
 * = Electrical Code Designator (see Nomenclature details)
 ^ = Motor Code Designator (see Nomenclature details)
 Net Capacity is available upon request

PERFORMANCE DATA

Application Capacity: Low Temperature Hot Gas Defrost- 50 Hz (For PSC Motors)[†]

Please consult AWEF table on pages 46 & 47 to confirm model meets DOE minimum AWEF

Please refer to Table 1: Capacity Correction Factors (page 6) if using Saturated Suction Temperatures different than listed in the information below

FPI	New Model	Legacy Model	R-404A/R-507A		R-448A/R-449A		Fan Data		
			Application Capacity ¹		Application Capacity ¹				
			10°F TD/-20°F SST	6°C TD/-29°C SST	10°F TD/-20°F SST	6°C TD/-29°C SST	No. of Fans	CFM	m ³ H
			BTUH	Watts	BTUH	Watts			
6	CEL0040*S6H^A	LSH035 LSH040	3,325	950	3,705	950	1	617	1,048
6	CEL0045*S6H^A	LSH040 LSH047	4,465	1,330	5,035	1,520	1	576	979
6	CEL0065*S6H^A	LSH065	6,175	1,805	6,840	1,995	2	1,234	2,096
6	CEL0080*S6H^A	LSH075	7,125	2,090	7,980	2,375	2	1,234	2,096
6	CEL0100*S6H^A	LSH090	8,550	2,470	9,405	2,755	2	1,153	1,959
6	CEL0130*S6H^A	LSH120	11,400	3,325	12,825	3,800	3	1,850	3,144
6	CEL0155*S6H^A	LSH140	13,300	3,895	15,200	4,465	3	1,729	2,938
6	CEL0170*S6H^A	LSH160	15,200	4,465	17,005	4,940	4	2,467	4,192
6	CEL0205*S6H^A	LSH180	17,100	5,035	19,095	5,605	4	2,306	3,918
6	CEL0240*S6H^A	LSH200	19,000	5,605	21,660	6,270	5	2,882	4,897
6	CEL0255*S6H^A	LSH240	22,800	6,650	25,555	7,505	6	3,701	6,288
6	CEL0310*S6H^A	LSH280	26,600	7,790	29,830	8,740	6	2,459	5,876
4	CEL0045*S4H^A	LSH041	3,895	1,140	4,275	1,235	1	600	1,019
4	CEL0070*S4H^A	LSH068	6,460	1,900	7,030	2,090	2	1,283	2,180
4	CEL0090*S4H^A	LSH080	7,600	2,185	8,360	2,470	2	1,199	2,037
4	CEL0135*S4H^A	LSH102	9,690	2,850	12,160	3,515	3	1,799	3,056
4	CEL0180*S4H^A	LSH136	12,920	3,800	16,435	4,750	4	2,398	4,074
4	CEL0220*S4H^A	LSH170	16,150	4,750	18,525	5,320	5	2,998	5,093
4	CEL0275*S4H^A	LSH204 LSH235	22,325	6,555	24,605	7,220	6	3,597	6,111

Notes:

¹ = Capacities shown are Application Capacities reflecting nominal operation at 10°F TD. For models within the scope of the DOE AWEF (Annual Walk-in Energy Factor) standard, the Net Capacity is determined by the AHRI 1250 test method. DOE will publish this compliance data at www.regulations.doe.gov

* = Electrical Code Designator (see Nomenclature details)

^ = Motor Code Designator (see Nomenclature details)

Net Capacity is available upon request

[†] = For 1-speed and 2-speed EC motors, use 60 Hz capacity and airflow values. (units with EC motors operating at 50 Hz will not see a reduction in performance due to the electronic control of the motor)

PERFORMANCE DATA

Application Capacity: Low Temperature Hot Gas Defrost- 50 Hz (For PSC Motors)[†]

Please consult AWEF table on pages 46 & 47 to confirm model meets DOE minimum AWEF

Please refer to Table 1: Capacity Correction Factors (page 6) if using Saturated Suction Temperatures different than listed in the information below

FPI	New Model	Legacy Model	R-407A/R-407F		R-407C		Fan Data		
			Application Capacity ¹		Application Capacity ¹				
			10°F TD/-20°F SST	6°C TD/-29°C SST	10°F TD/-20°F SST	6°C TD/-29°C SST	No. of Fans	CFM	m ³ H
			BTUH	Watts	BTUH	Watts			
6	CEL0040*S6H^A	LSH035 LSH040	3,705	950	-	-	1	617	1,048
6	CEL0045*S6H^A	LSH040 LSH047	5,035	1,520	-	-	1	576	979
6	CEL0065*S6H^A	LSH065	6,840	1,995	-	-	2	1,234	2,096
6	CEL0080*S6H^A	LSH075	7,980	2,375	-	-	2	1,234	2,096
6	CEL0100*S6H^A	LSH090	9,405	2,755	-	-	2	1,153	1,959
6	CEL0130*S6H^A	LSH120	12,825	3,800	-	-	3	1,850	3,144
6	CEL0155*S6H^A	LSH140	15,200	4,465	-	-	3	1,729	2,938
6	CEL0170*S6H^A	LSH160	17,005	4,940	-	-	4	2,467	4,192
6	CEL0205*S6H^A	LSH180	19,095	5,605	-	-	4	2,306	3,918
6	CEL0240*S6H^A	LSH200	21,280	6,175	-	-	5	2,882	4,897
6	CEL0255*S6H^A	LSH240	25,555	7,505	-	-	6	3,701	6,288
6	CEL0310*S6H^A	LSH280	29,830	8,740	-	-	6	2,459	5,876
4	CEL0045*S4H^A	LSH041	4,275	1,235	-	-	1	600	1,019
4	CEL0070*S4H^A	LSH068	7,030	2,090	-	-	2	1,283	2,180
4	CEL0090*S4H^A	LSH080	8,360	2,470	-	-	2	1,199	2,037
4	CEL0135*S4H^A	LSH102	11,495	3,325	-	-	3	1,799	3,056
4	CEL0180*S4H^A	LSH136	15,485	4,465	-	-	4	2,398	4,074
4	CEL0220*S4H^A	LSH170	18,620	5,225	-	-	5	2,998	5,093
4	CEL0275*S4H^A	LSH204 LSH235	24,605	7,220	-	-	6	3,597	6,111

Notes:

¹ = Capacities shown are Application Capacities reflecting nominal operation at 10°F TD. For models within the scope of the DOE AWEF (Annual Walk-in Energy Factor) standard, the Net Capacity is determined by the AHRI 1250 test method. DOE will publish this compliance data at www.regulations.doe.gov

* = Electrical Code Designator (see Nomenclature details)

^ = Motor Code Designator (see Nomenclature details)

Net Capacity is available upon request

[†] = For 1-speed and 2-speed EC motors, use 60 Hz capacity and airflow values. (units with EC motors operating at 50 Hz will not see a reduction in performance due to the electronic control of the motor)

PERFORMANCE DATA

Application Capacity: Medium Temperature Hot Gas Defrost- 60 Hz

Please consult AWEF table on pages 46 & 47 to confirm model meets DOE minimum AWEF

Please refer to Table 1: Capacity Correction Factors (page 6) if using Saturated Suction Temperatures different than listed in the information below

FPI	New Model	Legacy Model	R-404A/R-507A		R-448A/R-449A		Fan Data		
			Application Capacity ¹		Application Capacity ¹				
			10°F TD/25°F SST	6°C TD/-4°F SST	10°F TD/25°F SST	6°C TD/-4°F SST	No. of Fans	CFM	m ³ H
			BTUH	Watts	BTUH	Watts			
6	CEL0040*S6H^A	LSH035 LSH040	4,000	1,200	4,500	1,300	1	685	1,164
6	CEL0045*S6H^A	LSH040 LSH047	5,400	1,550	6,100	1,750	1	641	1,088
6	CEL0065*S6H^A	LSH065	7,450	2,150	8,300	2,400	2	1,371	2,329
6	CEL0080*S6H^A	LSH075	8,650	2,500	9,650	2,800	2	1,371	2,329
6	CEL0100*S6H^A	LSH090	10,350	3,000	11,400	3,300	2	1,281	2,176
6	CEL0130*S6H^A	LSH120	13,800	4,000	15,500	4,500	3	2,056	3,493
6	CEL0155*S6H^A	LSH140	16,100	4,650	18,400	5,300	3	1,922	3,265
6	CEL0170*S6H^A	LSH160	18,400	5,300	20,600	5,950	4	2,741	4,658
6	CEL0205*S6H^A	LSH180	20,700	6,000	23,100	6,650	4	2,562	4,353
6	CEL0240*S6H^A	LSH200	23,000	6,650	25,750	7,450	5	3,203	5,441
6	CEL0255*S6H^A	LSH240	27,600	7,950	30,950	8,950	6	4,112	6,986
6	CEL0310*S6H^A	LSH280	32,200	9,300	36,100	10,400	6	3,843	6,529
4	CEL0045*S4H^A	LSH041	4,700	1,400	5,200	1,500	1	667	1,132
4	CEL0070*S4H^A	LSH068	7,800	2,250	8,500	2,450	2	1,425	2,422
4	CEL0090*S4H^A	LSH080	9,200	2,650	10,100	2,900	2	1,332	2,263
4	CEL0135*S4H^A	LSH102	11,750	3,400	13,050	3,800	3	1,998	3,395
4	CEL0180*S4H^A	LSH136	15,650	4,500	17,650	5,100	4	2,664	4,527
4	CEL0220*S4H^A	LSH170	19,550	5,650	21,850	6,300	5	3,331	5,659
4	CEL0275*S4H^A	LSH204 LSH235	27,000	7,800	29,800	8,600	6	3,997	6,790

Notes:

¹ = Capacities shown are Application Capacities reflecting nominal operation at 10°F TD. For models within the scope of the DOE AWEF (Annual Walk-in Energy Factor) standard, the Net Capacity is determined by the AHRI 1250 test method. DOE will publish this compliance data at www.regulations.doe.gov

* = Electrical Code Designator (see Nomenclature details)

^ = Motor Code Designator (see Nomenclature details)

Net Capacity is available upon request

PERFORMANCE DATA

Application Capacity: Medium Temperature Hot Gas Defrost- 60 Hz

Please consult AWEF table on pages 46 & 47 to confirm model meets DOE minimum AWEF

Please refer to Table 1: Capacity Correction Factors (page 6) if using Saturated Suction Temperatures different than listed in the information below

FPI	New Model	Legacy Model	R-407A/R-407F		R-407C		Fan Data		
			Application Capacity ¹		Application Capacity ¹				
			10°F TD/25°F SST	6°C TD/-4°F SST	10°F TD/25°F SST	6°C TD/-4°F SST	No. of Fans	CFM	m ³ H
			BTUH	Watts	BTUH	Watts			
6	CEL0040*S6H^A	LSH035 LSH040	4,500	1,300	-	-	1	685	1,164
6	CEL0045*S6H^A	LSH040 LSH047	6,100	1,750	-	-	1	641	1,088
6	CEL0065*S6H^A	LSH065	8,300	2,400	-	-	2	1,371	2,329
6	CEL0080*S6H^A	LSH075	9,650	2,800	-	-	2	1,371	2,329
6	CEL0100*S6H^A	LSH090	11,400	3,300	-	-	2	1,281	2,176
6	CEL0130*S6H^A	LSH120	15,500	4,500	-	-	3	2,056	3,493
6	CEL0155*S6H^A	LSH140	18,400	5,300	-	-	3	1,922	3,265
6	CEL0170*S6H^A	LSH160	20,600	5,950	-	-	4	2,741	4,658
6	CEL0205*S6H^A	LSH180	23,100	6,650	-	-	4	2,562	4,353
6	CEL0240*S6H^A	LSH200	25,750	7,450	-	-	5	3,203	5,441
6	CEL0255*S6H^A	LSH240	30,950	8,950	-	-	6	4,112	6,986
6	CEL0310*S6H^A	LSH280	36,100	10,400	-	-	6	3,843	6,529
4	CEL0045*S4H^A	LSH041	5,200	1,500	-	-	1	667	1,132
4	CEL0070*S4H^A	LSH068	8,500	2,450	-	-	2	1,425	2,422
4	CEL0090*S4H^A	LSH080	10,100	2,900	-	-	2	1,332	2,263
4	CEL0135*S4H^A	LSH102	13,050	3,800	-	-	3	1,998	3,395
4	CEL0180*S4H^A	LSH136	17,650	5,100	-	-	4	2,664	4,527
4	CEL0220*S4H^A	LSH170	21,850	6,300	-	-	5	3,331	5,659
4	CEL0275*S4H^A	LSH204 LSH235	29,800	8,600	-	-	6	3,997	6,790

Notes:
¹ = Capacities shown are Application Capacities reflecting nominal operation at 10°F TD. For models within the scope of the DOE AWEF (Annual Walk-in Energy Factor) standard, the Net Capacity is determined by the AHRI 1250 test method. DOE will publish this compliance data at www.regulations.doe.gov
 * = Electrical Code Designator (see Nomenclature details)
 ^ = Motor Code Designator (see Nomenclature details)
 Net Capacity is available upon request

SPECIFICATIONS

Hot Gas Defrost- 60 Hz

Please consult AWEF table on pages 46 & 47 to confirm model meets DOE minimum AWEF

FPI	New Model	HP	2-Speed EC Motor (Totally Enclosed)				Drain Pan Heaters			
			115/1/60				Watts	115/1/60	230/1/60	460/1/60
			Amps	Watts	MCA	MOPD		Total Amps		
6	CEL0040*S6HMA	1/20	0.9	55	1.1	20	150	1.3	0.7	0.3
6	CEL0045*S6HMA	1/20	0.9	55	1.1	20	150	1.3	0.7	0.3
6	CEL0065*S6HMA	1/20	1.8	110	2.0	20	300	2.6	1.3	0.7
6	CEL0080*S6HMA	1/20	1.8	110	2.0	20	300	2.6	1.3	0.7
6	CEL0100*S6HMA	1/20	1.8	110	2.0	20	300	2.6	1.3	0.7
6	CEL0130*S6HMA	1/20	2.7	165	2.9	20	450	3.9	2.0	1.0
6	CEL0155*S6HMA	1/20	2.7	165	2.9	20	450	3.9	2.0	1.0
6	CEL0170*S6HMA	1/20	3.6	220	3.8	20	600	5.2	2.6	1.3
6	CEL0205*S6HMA	1/20	3.6	220	3.8	20	600	5.2	2.6	1.3
6	CEL0240*S6HMA	1/20	4.5	275	4.7	20	750	6.5	3.3	1.6
6	CEL0255*S6HMA	1/20	5.4	330	5.6	20	900	7.8	3.9	2.0
6	CEL0310*S6HMA	1/20	5.4	330	5.6	20	900	7.8	3.9	2.0
4	CEL0045*S4HMA	1/20	0.9	55	1.1	20	150	1.3	0.7	0.3
4	CEL0070*S4HMA	1/20	1.8	110	2.0	20	300	2.6	1.3	0.7
4	CEL0090*S4HMA	1/20	1.8	110	2.0	20	300	2.6	1.3	0.7
4	CEL0135*S4HMA	1/20	2.7	165	2.9	20	450	3.9	2.0	1.0
4	CEL0180*S4HMA	1/20	3.6	220	3.8	20	600	5.2	2.6	1.3
4	CEL0220*S4HMA	1/20	4.5	275	4.7	20	750	6.5	3.3	1.6
4	CEL0275*S4HMA	1/20	5.4	330	5.6	20	900	7.8	3.9	2.0

FPI	New Model	HP	2-Speed EC Motor (Totally Enclosed)				Drain Pan Heaters			
			208-230/1/60				Watts	115/1/60	230/1/60	460/1/60
			Amps	Watts	MCA	MOPD		Total Amps		
6	CEL0040*S6HMA	1/20	0.5	55	0.6	15	150	1.3	0.7	0.3
6	CEL0045*S6HMA	1/20	0.5	55	0.6	15	150	1.3	0.7	0.3
6	CEL0065*S6HMA	1/20	1.0	110	1.1	15	300	2.6	1.3	0.7
6	CEL0080*S6HMA	1/20	1.0	110	1.1	15	300	2.6	1.3	0.7
6	CEL0100*S6HMA	1/20	1.0	110	1.1	15	300	2.6	1.3	0.7
6	CEL0130*S6HMA	1/20	1.4	165	1.6	15	450	3.9	2.0	1.0
6	CEL0155*S6HMA	1/20	1.4	165	1.6	15	450	3.9	2.0	1.0
6	CEL0170*S6HMA	1/20	1.9	220	2.1	15	600	5.2	2.6	1.3
6	CEL0205*S6HMA	1/20	1.9	220	2.1	15	600	5.2	2.6	1.3
6	CEL0240*S6HMA	1/20	2.4	275	2.6	15	750	6.5	3.3	1.6
6	CEL0255*S6HMA	1/20	2.9	330	3.1	15	900	7.8	3.9	2.0
6	CEL0310*S6HMA	1/20	2.9	330	3.1	15	900	7.8	3.9	2.0
4	CEL0045*S4HMA	1/20	0.5	55	0.6	15	150	1.3	0.7	0.3
4	CEL0070*S4HMA	1/20	1.0	110	1.1	15	300	2.6	1.3	0.7
4	CEL0090*S4HMA	1/20	1.0	110	1.1	15	300	2.6	1.3	0.7
4	CEL0135*S4HMA	1/20	1.4	165	1.6	15	450	3.9	2.0	1.0
4	CEL0180*S4HMA	1/20	1.9	220	2.1	15	600	5.2	2.6	1.3
4	CEL0220*S4HMA	1/20	2.4	275	2.6	15	750	6.5	3.3	1.6
4	CEL0275*S4HMA	1/20	2.9	330	3.1	15	900	7.8	3.9	2.0

Notes:

* = Electrical Code Designator (see Nomenclature details)

SPECIFICATIONS

Hot Gas Defrost- 60 Hz

Please consult AWEF table on pages 46 & 47 to confirm model meets DOE minimum AWEF

FPI	New Model	HP	1-Speed EC Motor (Totally Enclosed)				Drain Pan Heaters			
			115/1/60				Watts	115/1/60	230/1/60	460/1/60
			Amps	Watts	MCA	MOPD		Total Amps		
6	CEL0040*S6HEA	1/20	0.9	55	1.1	20	150	1.3	0.7	0.3
6	CEL0045*S6HEA	1/20	0.9	55	1.1	20	150	1.3	0.7	0.3
6	CEL0065*S6HEA	1/20	1.8	110	2.0	20	300	2.6	1.3	0.7
6	CEL0080*S6HEA	1/20	1.8	110	2.0	20	300	2.6	1.3	0.7
6	CEL0100*S6HEA	1/20	1.8	110	2.0	20	300	2.6	1.3	0.7
6	CEL0130*S6HEA	1/20	2.7	165	2.9	20	450	3.9	2.0	1.0
6	CEL0155*S6HEA	1/20	2.7	165	2.9	20	450	3.9	2.0	1.0
6	CEL0170*S6HEA	1/20	3.6	220	3.8	20	600	5.2	2.6	1.3
6	CEL0205*S6HEA	1/20	3.6	220	3.8	20	600	5.2	2.6	1.3
6	CEL0240*S6HEA	1/20	4.5	270	4.7	20	750	6.5	3.3	1.6
6	CEL0255*S6HEA	1/20	5.4	330	5.6	20	900	7.8	3.9	2.0
6	CEL0310*S6HEA	1/20	5.4	330	5.6	20	900	7.8	3.9	2.0
4	CEL0045*S4HEA	1/20	0.9	55	1.1	20	150	1.3	0.7	0.3
4	CEL0070*S4HEA	1/20	1.8	110	2.0	20	300	2.6	1.3	0.7
4	CEL0090*S4HEA	1/20	1.8	110	2.0	20	300	2.6	1.3	0.7
4	CEL0135*S4HEA	1/20	2.7	165	2.9	20	450	3.9	2.0	1.0
4	CEL0180*S4HEA	1/20	3.6	220	3.8	20	600	5.2	2.6	1.3
4	CEL0220*S4HEA	1/20	4.5	275	4.7	20	750	6.5	3.3	1.6
4	CEL0275*S4HEA	1/20	5.4	330	5.6	20	900	7.8	3.9	2.0

FPI	New Model	HP	1-Speed EC Motor (Totally Enclosed)				Drain Pan Heaters			
			208-230/1/60				Watts	115/1/60	230/1/60	460/1/60
			Amps	Watts	MCA	MOPD		Total Amps		
6	CEL0040*S6HEA	1/20	0.5	59	0.6	15	150	1.3	0.7	0.3
6	CEL0045*S6HEA	1/20	0.5	59	0.6	15	150	1.3	0.7	0.3
6	CEL0065*S6HEA	1/20	1.0	118	1.1	15	300	2.6	1.3	0.7
6	CEL0080*S6HEA	1/20	1.0	118	1.1	15	300	2.6	1.3	0.7
6	CEL0100*S6HEA	1/20	1.0	118	1.1	15	300	2.6	1.3	0.7
6	CEL0130*S6HEA	1/20	1.5	177	1.6	15	450	3.9	2.0	1.0
6	CEL0155*S6HEA	1/20	1.5	177	1.6	15	450	3.9	2.0	1.0
6	CEL0170*S6HEA	1/20	2.0	236	2.1	15	600	5.2	2.6	1.3
6	CEL0205*S6HEA	1/20	2.0	236	2.1	15	600	5.2	2.6	1.3
6	CEL0240*S6HEA	1/20	2.5	295	2.6	15	750	6.5	3.3	1.6
6	CEL0255*S6HEA	1/20	3.0	354	3.1	15	900	7.8	3.9	2.0
6	CEL0310*S6HEA	1/20	3.0	354	3.1	15	900	7.8	3.9	2.0
4	CEL0045*S4HEA	1/20	0.5	59	0.6	15	150	1.3	0.7	0.3
4	CEL0070*S4HEA	1/20	1.0	118	1.1	15	300	2.6	1.3	0.7
4	CEL0090*S4HEA	1/20	1.0	118	1.1	15	300	2.6	1.3	0.7
4	CEL0135*S4HEA	1/20	1.5	177	1.6	15	450	3.9	2.0	1.0
4	CEL0180*S4HEA	1/20	2.0	236	2.1	15	600	5.2	2.6	1.3
4	CEL0220*S4HEA	1/20	2.5	295	2.6	15	750	6.5	3.3	1.6
4	CEL0275*S4HEA	1/20	3.0	354	3.1	15	900	7.8	3.9	2.0

Notes:

* = Electrical Code Designator (see Nomenclature details)

SPECIFICATIONS

Hot Gas Defrost- 60 Hz

Please consult AWEF table on pages 46 & 47 to confirm model meets DOE minimum AWEF

FPI	New Model	HP	PSC Motor (Totally Enclosed)				Drain Pan Heaters			
			115/1/60				Watts	115/1/60	230/1/60	460/1/60
			Amps	Watts	MCA	MOPD		Total Amps		
6	CEL0040*S6HCA	1/20	1.0	82	1.3	20	150	1.3	0.7	0.3
6	CEL0045*S6HCA	1/20	1.0	82	1.3	20	150	1.3	0.7	0.3
6	CEL0065*S6HCA	1/20	2.0	164	2.3	20	300	2.6	1.3	0.7
6	CEL0080*S6HCA	1/20	2.0	164	2.3	20	300	2.6	1.3	0.7
6	CEL0100*S6HCA	1/20	2.0	164	2.3	20	300	2.6	1.3	0.7
6	CEL0130*S6HCA	1/20	3.0	246	3.3	20	450	3.9	2.0	1.0
6	CEL0155*S6HCA	1/20	3.0	246	3.3	20	450	3.9	2.0	1.0
6	CEL0170*S6HCA	1/20	4.0	328	4.3	20	600	5.2	2.6	1.3
6	CEL0205*S6HCA	1/20	4.0	328	4.3	20	600	5.2	2.6	1.3
6	CEL0240*S6HCA	1/20	5.0	410	5.3	20	750	6.5	3.3	1.6
6	CEL0255*S6HCA	1/20	6.0	492	6.3	20	900	7.8	3.9	2.0
6	CEL0310*S6HCA	1/20	6.0	492	6.3	20	900	7.8	3.9	2.0
4	CEL0045*S4HCA	1/20	1.0	82	1.3	20	150	1.3	0.7	0.3
4	CEL0070*S4HCA	1/20	2.0	164	2.3	20	300	2.6	1.3	0.7
4	CEL0090*S4HCA	1/20	2.0	164	2.3	20	300	2.6	1.3	0.7
4	CEL0135*S4HCA	1/20	3.0	246	3.3	20	450	3.9	2.0	1.0
4	CEL0180*S4HCA	1/20	4.0	328	4.3	20	600	5.2	2.6	1.3
4	CEL0220*S4HCA	1/20	5.0	410	5.3	20	750	6.5	3.3	1.6
4	CEL0275*S4HCA	1/20	6.0	492	6.3	20	900	7.8	3.9	2.0

FPI	New Model	HP	PSC Motor (Totally Enclosed)				Drain Pan Heaters			
			208-230/1/60				Watts	115/1/60	230/1/60	460/1/60
			Amps	Watts	MCA	MOPD		Total Amps		
6	CEL0040*S6HCA	1/20	0.5	91	0.6	15	150	1.3	0.7	0.3
6	CEL0045*S6HCA	1/20	0.5	91	0.6	15	150	1.3	0.7	0.3
6	CEL0065*S6HCA	1/20	1.0	182	1.1	15	300	2.6	1.3	0.7
6	CEL0080*S6HCA	1/20	1.0	182	1.1	15	300	2.6	1.3	0.7
6	CEL0100*S6HCA	1/20	1.0	182	1.1	15	300	2.6	1.3	0.7
6	CEL0130*S6HCA	1/20	1.5	273	1.6	15	450	3.9	2.0	1.0
6	CEL0155*S6HCA	1/20	1.5	273	1.6	15	450	3.9	2.0	1.0
6	CEL0170*S6HCA	1/20	2.0	364	2.1	15	600	5.2	2.6	1.3
6	CEL0205*S6HCA	1/20	2.0	364	2.1	15	600	5.2	2.6	1.3
6	CEL0240*S6HCA	1/20	2.5	455	2.6	15	750	6.5	3.3	1.6
6	CEL0255*S6HCA	1/20	3.0	546	3.1	15	900	7.8	3.9	2.0
6	CEL0310*S6HCA	1/20	3.0	546	3.1	15	900	7.8	3.9	2.0
4	CEL0045*S4HCA	1/20	0.5	91	0.6	15	150	1.3	0.7	0.3
4	CEL0070*S4HCA	1/20	1.0	182	1.1	15	300	2.6	1.3	0.7
4	CEL0090*S4HCA	1/20	1.0	182	1.1	15	300	2.6	1.3	0.7
4	CEL0135*S4HCA	1/20	1.5	273	1.6	15	450	3.9	2.0	1.0
4	CEL0180*S4HCA	1/20	2.0	364	2.1	15	600	5.2	2.6	1.3
4	CEL0220*S4HCA	1/20	2.5	455	2.6	15	750	6.5	3.3	1.6
4	CEL0275*S4HCA	1/20	3.0	546	3.1	15	900	7.8	3.9	2.0

Notes:

* = Electrical Code Designator (see Nomenclature details)

SPECIFICATIONS

Hot Gas Defrost- 60 Hz

Please consult AWEF table on pages 46 & 47 to confirm model meets DOE minimum AWEF

FPI	New Model	HP	PSC Motor (Totally Enclosed)				Drain Pan Heaters			
			460/1/60				Watts	115/1/60	230/1/60	460/1/60
			Amps	Watts	MCA	MOPD		Total Amps		
6	CEL0040*S6HCA	1/20	0.4	117	0.5	15	150	1.3	0.7	0.3
6	CEL0045*S6HCA	1/20	0.4	117	0.5	15	150	1.3	0.7	0.3
6	CEL0065*S6HCA	1/20	0.8	234	0.9	15	300	2.6	1.3	0.7
6	CEL0080*S6HCA	1/20	0.8	234	0.9	15	300	2.6	1.3	0.7
6	CEL0100*S6HCA	1/20	0.8	234	0.9	15	300	2.6	1.3	0.7
6	CEL0130*S6HCA	1/20	1.2	351	1.3	15	450	3.9	2.0	1.0
6	CEL0155*S6HCA	1/20	1.2	351	1.3	15	450	3.9	2.0	1.0
6	CEL0170*S6HCA	1/20	1.6	468	1.7	15	600	5.2	2.6	1.3
6	CEL0205*S6HCA	1/20	1.6	468	1.7	15	600	5.2	2.6	1.3
6	CEL0240*S6HCA	1/20	2.0	585	2.1	15	750	6.5	3.3	1.6
6	CEL0255*S6HCA	1/20	2.4	702	2.5	15	900	7.8	3.9	2.0
6	CEL0310*S6HCA	1/20	2.4	702	2.5	15	900	7.8	3.9	2.0
4	CEL0045*S4HCA	1/20	0.4	117	0.5	15	150	1.3	0.7	0.3
4	CEL0070*S4HCA	1/20	0.8	234	0.9	15	300	2.6	1.3	0.7
4	CEL0090*S4HCA	1/20	0.8	234	0.9	15	300	2.6	1.3	0.7
4	CEL0135*S4HCA	1/20	1.2	351	1.3	15	450	3.9	2.0	1.0
4	CEL0180*S4HCA	1/20	1.6	468	1.7	15	600	5.2	2.6	1.3
4	CEL0220*S4HCA	1/20	2.0	585	2.1	15	750	6.5	3.3	1.6
4	CEL0275*S4HCA	1/20	2.4	702	2.5	15	900	7.8	3.9	2.0

Notes:

* = Electrical Code Designator (see Nomenclature details)

SPECIFICATIONS

Hot Gas Defrost- 50 Hz

Please consult AWEF table on pages 46 & 47 to confirm model meets DOE minimum AWEF

FPI	New Model	HP	2-Speed EC Motor (Totally Enclosed)				Drain Pan Heaters	
			220/1/50				Watts	220/1/50
			Amps	Watts	MCA	MOPD		Total Amps
6	CEL0040*S6HMA	1/20	0.5	55	0.6	15	135	0.6
6	CEL0045*S6HMA	1/20	0.5	55	0.6	15	135	0.6
6	CEL0065*S6HMA	1/20	1.0	110	1.1	15	275	1.2
6	CEL0080*S6HMA	1/20	1.0	110	1.1	15	275	1.2
6	CEL0100*S6HMA	1/20	1.0	110	1.1	15	275	1.2
6	CEL0130*S6HMA	1/20	1.5	165	1.6	15	410	1.9
6	CEL0155*S6HMA	1/20	1.5	165	1.6	15	410	1.9
6	CEL0170*S6HMA	1/20	2.0	220	2.1	15	550	2.5
6	CEL0205*S6HMA	1/20	2.0	220	2.1	15	550	2.5
6	CEL0240*S6HMA	1/20	2.5	275	2.6	15	690	3.1
6	CEL0255*S6HMA	1/20	3.0	330	3.1	15	825	3.7
6	CEL0310*S6HMA	1/20	3.0	330	3.1	15	825	3.7
4	CEL0045*S4HMA	1/20	0.5	55	0.6	15	135	0.6
4	CEL0070*S4HMA	1/20	1.0	110	1.1	15	275	1.2
4	CEL0090*S4HMA	1/20	1.0	110	1.1	15	275	1.2
4	CEL0135*S4HMA	1/20	1.5	165	1.6	15	410	1.9
4	CEL0180*S4HMA	1/20	2.0	220	2.1	15	550	2.5
4	CEL0220*S4HMA	1/20	2.5	275	2.6	15	690	3.1
4	CEL0275*S4HMA	1/20	3.0	330	3.1	15	825	3.7

FPI	New Model	HP	1-Speed EC Motor (Totally Enclosed)				Drain Pan Heaters	
			220/1/50				Watts	220/1/50
			Amps	Watts	MCA	MOPD		Total Amps
6	CEL0040*S6HEA	1/20	0.5	59	0.6	15	135	0.6
6	CEL0045*S6HEA	1/20	0.5	59	0.6	15	135	0.6
6	CEL0065*S6HEA	1/20	1.0	118	1.1	15	275	1.2
6	CEL0080*S6HEA	1/20	1.0	118	1.1	15	275	1.2
6	CEL0100*S6HEA	1/20	1.0	118	1.1	15	275	1.2
6	CEL0130*S6HEA	1/20	1.5	177	1.6	15	410	1.9
6	CEL0155*S6HEA	1/20	1.5	177	1.6	15	410	1.9
6	CEL0170*S6HEA	1/20	2.0	236	2.1	15	550	2.5
6	CEL0205*S6HEA	1/20	2.0	236	2.1	15	550	2.5
6	CEL0240*S6HEA	1/20	2.5	295	2.6	15	690	3.1
6	CEL0255*S6HEA	1/20	3.0	354	3.1	15	825	3.7
6	CEL0310*S6HEA	1/20	3.0	354	3.1	15	825	3.7
4	CEL0045*S4HEA	1/20	0.5	59	0.6	15	135	0.6
4	CEL0070*S4HEA	1/20	1.0	118	1.1	15	275	1.2
4	CEL0090*S4HEA	1/20	1.0	118	1.1	15	275	1.2
4	CEL0135*S4HEA	1/20	1.5	177	1.6	15	410	1.9
4	CEL0180*S4HEA	1/20	2.0	236	2.1	15	550	2.5
4	CEL0220*S4HEA	1/20	2.5	295	2.6	15	690	3.1
4	CEL0275*S4HEA	1/20	3.0	354	3.1	15	825	3.7

Notes:

* = Electrical Code Designator (see Nomenclature details)

SPECIFICATIONS

Hot Gas Defrost- 50 Hz

Please consult AWEF table on pages 46 & 47 to confirm model meets DOE minimum AWEF

FPI	New Model	HP	PSC Motor (Totally Enclosed)				Drain Pan Heaters	
			220/1/50				Watts	220/1/50
			Amps	Watts	MCA	MOPD		Total Amps
6	CEL0040*S6HCA	1/20	0.5	65	0.6	15	135	0.6
6	CEL0045*S6HCA	1/20	0.5	65	0.6	15	135	0.6
6	CEL0065*S6HCA	1/20	1.0	130	1.1	15	275	1.2
6	CEL0080*S6HCA	1/20	1.0	130	1.1	15	275	1.2
6	CEL0100*S6HCA	1/20	1.0	130	1.1	15	275	1.2
6	CEL0130*S6HCA	1/20	1.5	195	1.6	15	410	1.9
6	CEL0155*S6HCA	1/20	1.5	195	1.6	15	410	1.9
6	CEL0170*S6HCA	1/20	2.0	260	2.1	15	550	2.5
6	CEL0205*S6HCA	1/20	2.0	260	2.1	15	550	2.5
6	CEL0240*S6HCA	1/20	2.5	325	2.6	15	690	3.1
6	CEL0255*S6HCA	1/20	3.0	390	3.1	15	825	3.7
6	CEL0310*S6HCA	1/20	3.0	390	3.1	15	825	3.7
4	CEL0045*S4HCA	1/20	0.5	65	0.6	15	135	0.6
4	CEL0070*S4HCA	1/20	1.0	130	1.1	15	275	1.2
4	CEL0090*S4HCA	1/20	1.0	130	1.1	15	275	1.2
4	CEL0135*S4HCA	1/20	1.5	195	1.6	15	410	1.9
4	CEL0180*S4HCA	1/20	2.0	260	2.1	15	550	2.5
4	CEL0220*S4HCA	1/20	2.5	325	2.6	15	690	3.1
4	CEL0275*S4HCA	1/20	3.0	390	3.1	15	825	3.7

Notes:

* = Electrical Code Designator (see Nomenclature details)

PHYSICAL DATA

Air Defrost (R-404A/R-507A, R-448A/R-449A, R-407A/R-407F, R-407C)

Model	No. of Fans	Coil Inlet OD	Suction OD	Equalizer OD	Drain MPT	Approx. Net Weight	
						lb	kg
CEL0045*S6A^A	1	1/2	1/2	1/4	3/4	33	15
CEL0055*S6A^A	1	1/2	5/8	1/4	3/4	36	16
CEL0060*S6A^A	1	1/2	5/8	1/4	3/4	36	16
CEL0095*S6A^A	2	1/2	5/8	1/4	3/4	51	23
CEL0105*S6A^A	2	1/2	5/8	1/4	3/4	52	24
CEL0115*S6A^A	2	1/2	5/8	1/4	3/4	56	26
CEL0125*S6A^A	2	1/2	7/8	1/4	3/4	56	26
CEL0155*S6A^A	3	1/2	7/8	1/4	3/4	67	30
CEL0190*S6A^A	3	1/2	7/8	1/4	3/4	73	33
CEL0250*S6A^A	4	1/2	7/8	1/4	3/4	94	43
CEL0295*S6A^A	5	1/2	7/8	1/4	3/4	115	52
CEL0350*S6A^A	6	1/2	1-1/8	1/4	3/4	133	60
CEL0380*S6A^A	6	1/2	1-1/8	1/4	3/4	137	62

Air Defrost (CO₂DX)

Model	No. of Fans	Coil Inlet ²	Suction OD ²	Drain MPT	Approx. Net Weight	
					lb	kg
CEL0045*C6A^A	1	3/8	3/8	3/4	33	15
CEL0055*C6A^A	1	3/8	3/8	3/4	36	16
CEL0060*C6A^A	1	3/8	3/8	3/4	36	16
CEL0095*C6A^A	2	3/8	3/8	3/4	51	23
CEL0105*C6A^A	2	3/8	3/8	3/4	52	24
CEL0115*C6A^A	2	3/8	3/8	3/4	56	26
CEL0125*C6A^A	2	3/8	3/8	3/4	56	26
CEL0155*C6A^A	3	3/8	3/8	3/4	67	30
CEL0190*C6A^A	3	3/8	3/8	3/4	73	33
CEL0250*C6A^A	4	3/8	1/2	3/4	94	43
CEL0295*C6A^A	5	3/8	1/2	3/4	115	52
CEL0350*C6A^A	6	3/8	1/2	3/4	133	60
CEL0380*C6A^A	6	1/2	5/8	3/4	137	62

Notes:

* = Electrical Code Designator (see Nomenclature details)

^ = Motor Code Designator (see Nomenclature details)

² = Connection sizes may vary, if TD is lesser or greater than 10°F

PHYSICAL DATA

Electric Defrost (R-404A/R-507A, R-448A/R-449A, R-407A/R-407F, R-407C)

FPI	Model	No. of Fans	Coil Inlet OD	Suction OD	Equalizer OD	Drain MPT	Approx. Net Weight	
							lb	kg
6	CEL0040*S6E^A	1	1/2	5/8	1/4	3/4	36	16
6	CEL0045*S6E^A	1	1/2	5/8	1/4	3/4	38	17
6	CEL0065*S6E^A	2	1/2	5/8	1/4	3/4	54	24
6	CEL0080*S6E^A	2	1/2	5/8	1/4	3/4	54	24
6	CEL0100*S6E^A	2	1/2	7/8	1/4	3/4	59	27
6	CEL0130*S6E^A	3	1/2	7/8	1/4	3/4	71	32
6	CEL0155*S6E^A	3	1/2	1-1/8	1/4	3/4	78	35
6	CEL0170*S6E^A	4	1/2	7/8	1/4	3/4	91	41
6	CEL0205*S6E^A	4	1/2	1-1/8	1/4	3/4	100	45
6	CEL0240*S6E^A	5	1/2	1-1/8	1/4	3/4	120	54
6	CEL0255*S6E^A	6	1/2	1-1/8	1/4	3/4	134	61
6	CEL0310*S6E^A	6	1/2	1-1/8	1/4	3/4	146	66
4	CEL0045*S4E^A	1	1/2	5/8	1/4	3/4	38	17
4	CEL0070*S4E^A	2	1/2	5/8	1/4	3/4	53	24
4	CEL0090*S4E^A	2	1/2	7/8	1/4	3/4	59	27
4	CEL0135*S4E^A	3	1/2	7/8	1/4	3/4	77	35
4	CEL0180*S4E^A	4	1/2	1-1/8	1/4	3/4	100	45
4	CEL0220*S4E^A	5	1/2	1-1/8	1/4	3/4	119	54
4	CEL0275*S4E^A	6	1/2	1-1/8	1/4	3/4	142	64

Electric Defrost (CO₂DX)

FPI	Model	No. of Fans	Coil Inlet ²	Suction OD ²	Drain MPT	Approx. Net Weight	
						lb	kg
6	CEL0040*C6E^A	1	3/8	3/8	3/4	36	16
6	CEL0045*C6E^A	1	3/8	3/8	3/4	38	17
6	CEL0065*C6E^A	2	3/8	3/8	3/4	54	24
6	CEL0080*C6E^A	2	3/8	1/2	3/4	54	24
6	CEL0100*C6E^A	2	3/8	1/2	3/4	59	27
6	CEL0130*C6E^A	3	3/8	1/2	3/4	71	32
6	CEL0155*C6E^A	3	3/8	1/2	3/4	78	35
6	CEL0170*C6E^A	4	3/8	1/2	3/4	91	41
6	CEL0205*C6E^A	4	3/8	1/2	3/4	100	45
6	CEL0240*C6E^A	5	3/8	5/8	3/4	120	54
6	CEL0255*C6E^A	6	3/8	5/8	3/4	134	61
6	CEL0310*C6E^A	6	3/8	5/8	3/4	146	66
4	CEL0045*C4E^A	1	3/8	3/8	3/4	38	17
4	CEL0070*C4E^A	2	3/8	3/8	3/4	53	24
4	CEL0090*C4E^A	2	3/8	1/2	3/4	59	27
4	CEL0135*C4E^A	3	3/8	1/2	3/4	77	35
4	CEL0180*C4E^A	4	3/8	1/2	3/4	100	45
4	CEL0220*C4E^A	5	3/8	1/2	3/4	119	54
4	CEL0275*C4E^A	6	3/8	5/8	3/4	142	64

Notes:

* = Electrical Code Designator (see Nomenclature details)

^ = Motor Code Designator (see Nomenclature details)

² = Connection sizes may vary, if TD is lesser or greater than 10°F

PHYSICAL DATA

Hot Gas Defrost

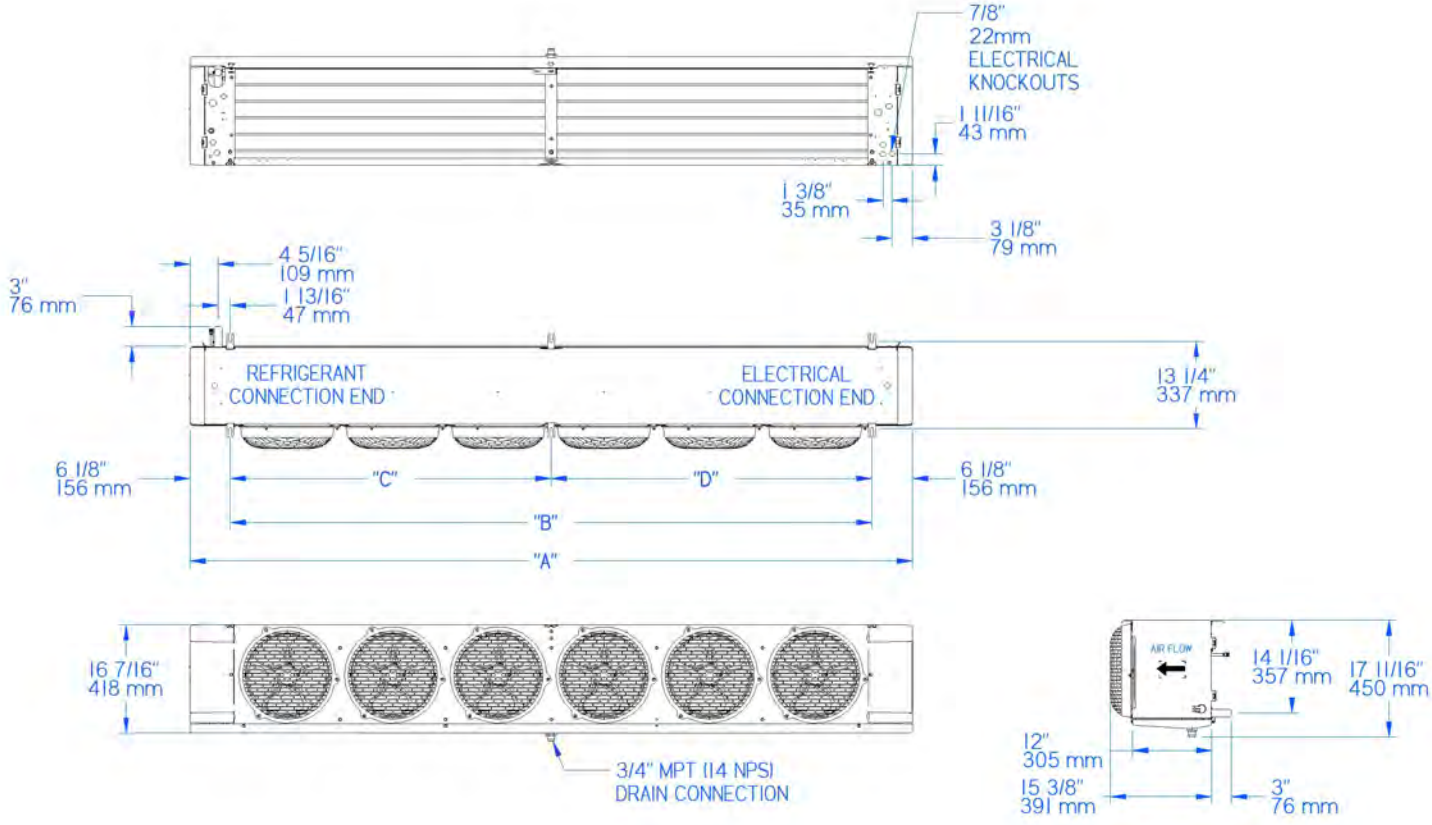
FPI	Model	No. of Fans	Coil Inlet OD	Suction OD	Equalizer OD	Drain MPT	Side Port OD	Hot Gas Pan Connection OD	Approx. Net Weight	
									lb	kg
6	CEL0040*S6H^A	1	1/2	5/8	1/4	3/4	1/2	5/8	38	17
6	CEL0045*S6H^A	1	1/2	5/8	1/4	3/4	1/2	5/8	40	18
6	CEL0065*S6H^A	2	1/2	5/8	1/4	3/4	1/2	5/8	56	25
6	CEL0080*S6H^A	2	1/2	5/8	1/4	3/4	1/2	5/8	56	25
6	CEL0100*S6H^A	2	1/2	7/8	1/4	3/4	1/2	5/8	61	27
6	CEL0130*S6H^A	3	1/2	7/8	1/4	3/4	1/2	5/8	73	33
6	CEL0155*S6H^A	3	1/2	1-1/8	1/4	3/4	1/2	5/8	80	36
6	CEL0170*S6H^A	4	1/2	7/8	1/4	3/4	1/2	5/8	93	42
6	CEL0205*S6H^A	4	1/2	1-1/8	1/4	3/4	1/2	5/8	102	46
6	CEL0240*S6H^A	5	1/2	1-1/8	1/4	3/4	1/2	5/8	122	55
6	CEL0255*S6H^A	6	1/2	1-1/8	1/4	3/4	1/2	5/8	136	62
6	CEL0310*S6H^A	6	1/2	1-1/8	1/4	3/4	1/2	5/8	148	67
4	CEL0045*S4H^A	1	1/2	5/8	1/4	3/4	1/2	5/8	40	18
4	CEL0070*S4H^A	2	1/2	5/8	1/4	3/4	1/2	5/8	55	25
4	CEL0090*S4H^A	2	1/2	7/8	1/4	3/4	1/2	5/8	61	28
4	CEL0135*S4H^A	3	1/2	7/8	1/4	3/4	1/2	5/8	79	36
4	CEL0180*S4H^A	4	1/2	1-1/8	1/4	3/4	1/2	5/8	102	46
4	CEL0220*S4H^A	5	1/2	1-1/8	1/4	3/4	1/2	5/8	121	55
4	CEL0275*S4H^A	6	1/2	1-1/8	1/4	3/4	1/2	5/8	144	65

Notes:

* = Electrical Code Designator (see Nomenclature details)

^ = Motor Code Designator (see Nomenclature details)

DIMENSIONAL DRAWINGS



No. of Fans	A		B		C		D	
	in.	mm	in.	mm	in.	mm	in.	mm
1	29.5	749	17.25	438	-	-	-	-
2	45.5	1,156	33.25	845	-	-	-	-
3	61.5	1,562	49.25	1,251	-	-	-	-
4	77.5	1,969	65.25	1,657	-	-	-	-
5	93.5	2,375	81.25	2,064	48.63	1,235	32.63	829
6	109.5	2,781	97.25	2,470	48.63	1,235	48.63	1,235

Note:
Hanger brackets will accept 3/8" / 9.5 mm hanger rods

DOE Rated AWEF

AWEF DATA

Air Defrost/2-Speed EC Motors

FPI	Model	Cooler				
		R-404A/ R-507A	R-448A/ R-449A	R-407A/ R-407F	R-407C	CO ₂ DX
		AWEF	AWEF	AWEF	AWEF	AWEF
6	CEL0045*±6AMA	9.00	9.00	9.00	9.00	9.00
6	CEL0055*±6AMA	9.00	9.00	9.00	9.00	9.00
6	CEL0060*±6AMA	9.00	9.00	9.00	9.00	9.00
6	CEL0095*±6AMA	9.00	9.00	9.00	9.00	9.00
6	CEL0105*±6AMA	9.00	9.00	9.00	9.00	9.00
6	CEL0115*±6AMA	9.00	9.00	9.00	9.00	9.00
6	CEL0125*±6AMA	9.00	9.00	9.00	9.00	9.00
6	CEL0155*±6AMA	9.00	9.00	9.00	9.00	9.00
6	CEL0190*±6AMA	9.00	9.00	9.00	9.00	9.00
6	CEL0250*±6AMA	9.00	9.00	9.00	9.00	9.00
6	CEL0295*±6AMA	9.00	9.00	9.00	9.00	9.00
6	CEL0350*±6AMA	9.00	9.00	9.00	9.00	9.00
6	CEL0380*±6AMA	9.00	9.00	9.00	9.00	9.00

Notes:

* = Electrical Code Designator (see Nomenclature details)

^ = Motor Code Designator (see Nomenclature details)

² = Connection sizes may vary, if TD is lesser or greater than 10°F

DOE Rated AWEF

 **AWEF DATA**

Electric Defrost/1-Speed EC Motors

FPI	Model	Freezer				
		R-404A/ R-507A	R-448A/ R-449A	R-407A/ R-407F	R-407C	CO ₂ DX
		AWEF	AWEF	AWEF	AWEF	AWEF
6	CEL0040*±6EEA	3.96	3.96	3.96	-	3.96
6	CEL0045*±6EEA	3.96	3.96	3.96	-	3.96
6	CEL0065*±6EEA	4.00	4.03	4.02	-	4.00
6	CEL0080*±6EEA	4.03	4.03	4.03	-	4.03
6	CEL0100*±6EEA	4.00	4.06	4.06	-	4.00
6	CEL0130*±6EEA	4.09	4.09	4.09	-	4.09
6	CEL0155*±6EEA	4.10	4.10	4.10	-	4.10
6	CEL0170*±6EEA	4.14	4.14	4.14	-	4.14
6	CEL0205*±6EEA	4.15	4.15	4.15	-	4.15
6	CEL0240*±6EEA	4.15	4.15	4.15	-	4.15
6	CEL0255*±6EEA	4.15	4.15	4.15	-	4.15
6	CEL0310*±6EEA	4.15	4.15	4.15	-	4.15
4	CEL0045*±4EEA	3.96	3.96	3.96	-	3.96
4	CEL0070*±4EEA	3.99	3.99	3.99	-	-
4	CEL0090*±4EEA	4.02	4.02	4.02	-	4.02
4	CEL0135*±4EEA	4.07	4.07	4.07	-	4.07
4	CEL0180*±4EEA	4.12	4.12	4.12	-	4.12
4	CEL0220*±4EEA	4.15	4.15	4.15	-	4.15
4	CEL0275*±4EEA	4.15	4.15	4.15	-	4.15

DOE Rated AWEF

AWEF DATA

Electric Defrost/2-Speed EC Motors

FPI	Model	Cooler				
		R-404A/ R-507A	R-448A/ R-449A	R-407A/ R-407F	R-407C	CO ₂ DX
		AWEF	AWEF	AWEF	AWEF	AWEF
6	CEL0040*±6EMA	9.00	9.00	9.00	-	9.00
6	CEL0045*±6EMA	9.00	9.00	9.00	-	9.00
6	CEL0065*±6EMA	9.00	9.00	9.00	-	9.00
6	CEL0080*±6EMA	9.00	9.00	9.00	-	9.00
6	CEL0100*±6EMA	9.00	9.00	9.00	-	9.00
6	CEL0130*±6EMA	9.00	9.00	9.00	-	9.00
6	CEL0155*±6EMA	9.00	9.00	9.00	-	9.00
6	CEL0170*±6EMA	9.00	9.00	9.00	-	9.00
6	CEL0205*±6EMA	9.00	9.00	9.00	-	9.00
6	CEL0240*±6EMA	9.00	9.00	9.00	-	9.00
6	CEL0255*±6EMA	9.00	9.00	9.00	-	9.00
6	CEL0310*±6EMA	9.00	9.00	9.00	-	9.00
4	CEL0045*±4EMA	9.00	9.00	9.00	-	9.00
4	CEL0070*±4EMA	9.00	9.00	9.00	-	-
4	CEL0090*±4EMA	9.00	9.00	9.00	-	9.00
4	CEL0135*±4EMA	9.00	9.00	9.00	-	9.00
4	CEL0180*±4EMA	9.00	9.00	9.00	-	9.00
4	CEL0220*±4EMA	9.00	9.00	9.00	-	9.00
4	CEL0275*±4EMA	9.00	9.00	9.00	-	9.00

FPI	Model	Freezer				
		R-404A/ R-507A	R-448A/ R-449A	R-407A/ R-407F	R-407C	CO ₂ DX
		AWEF	AWEF	AWEF	AWEF	AWEF
6	CEL0040*±6EMA	3.96	3.96	3.96	-	3.96
6	CEL0045*±6EMA	3.96	3.96	3.96	-	3.96
6	CEL0065*±6EMA	4.00	4.03	4.02	-	4.00
6	CEL0080*±6EMA	4.00	4.00	4.00	-	4.00
6	CEL0100*±6EMA	4.03	4.03	4.03	-	4.03
6	CEL0130*±6EMA	4.06	4.06	4.06	-	4.06
6	CEL0155*±6EMA	4.09	4.09	4.09	-	4.09
6	CEL0170*±6EMA	4.10	4.10	4.10	-	4.10
6	CEL0205*±6EMA	4.14	4.14	4.14	-	4.14
6	CEL0240*±6EMA	4.15	4.15	4.15	-	4.15
6	CEL0255*±6EMA	4.15	4.15	4.15	-	4.15
6	CEL0310*±6EMA	4.15	4.15	4.15	-	4.15
4	CEL0045*±4EMA	3.96	3.96	3.96	-	3.96
4	CEL0070*±4EMA	3.99	3.99	3.99	-	-
4	CEL0090*±4EMA	4.02	4.02	4.02	-	4.02
4	CEL0135*±4EMA	4.07	4.07	4.07	-	4.07
4	CEL0180*±4EMA	4.12	4.12	4.12	-	4.12
4	CEL0220*±4EMA	4.15	4.15	4.15	-	4.15
4	CEL0275*±4EMA	4.15	4.15	4.15	-	4.15

DOE Rated AWEF

AWEF DATA

Hot Gas Defrost/1-Speed EC Motors

FPI	Model	Freezer			
		R-404A/ R-507A	R-448A/ R-449A	R-407A/ R-407F	R-407C
		AWEF	AWEF	AWEF	AWEF
6	CEL0040*S6HEA	3.96	3.96	3.96	-
6	CEL0045*S6HEA	3.96	3.96	3.96	-
6	CEL0065*S6HEA	4.00	4.03	4.02	-
6	CEL0080*S6HEA	4.03	4.03	4.03	-
6	CEL0100*S6HEA	4.06	4.06	4.06	-
6	CEL0130*S6HEA	4.09	4.09	4.09	-
6	CEL0155*S6HEA	4.10	4.10	4.10	-
6	CEL0170*S6HEA	4.14	4.14	4.14	-
6	CEL0205*S6HEA	4.15	4.15	4.15	-
6	CEL0240*S6HEA	4.15	4.15	4.15	-
6	CEL0255*S6HEA	4.15	4.15	4.15	-
6	CEL0310*S6HEA	4.15	4.15	4.15	-
4	CEL0045*S4HEA	3.96	3.96	3.96	-
4	CEL0070*S4HEA	3.99	3.99	3.99	-
4	CEL0090*S4HEA	4.02	4.02	4.02	-
4	CEL0135*S4HEA	4.07	4.07	4.07	-
4	CEL0180*S4HEA	4.12	4.12	4.12	-
4	CEL0220*S4HEA	4.15	4.15	4.15	-
4	CEL0275*S4HEA	4.15	4.15	4.15	-

DOE Rated AWEF

AWEF DATA

Hot Gas Defrost/Dual-Rated 2-Speed EC Motors

FPI	Model	Cooler			
		R-404A/ R-507A	R-448A/ R-449A	R-407A/ R-407F	R-407C
		AWEF	AWEF	AWEF	AWEF
6	CEL0040*S6HMA	9.00	9.00	9.00	-
6	CEL0045*S6HMA	9.00	9.00	9.00	-
6	CEL0065*S6HMA	9.00	9.00	9.00	-
6	CEL0080*S6HMA	9.00	9.00	9.00	-
6	CEL0100*S6HMA	9.00	9.00	9.00	-
6	CEL0130*S6HMA	9.00	9.00	9.00	-
6	CEL0155*S6HMA	9.00	9.00	9.00	-
6	CEL0170*S6HMA	9.00	9.00	9.00	-
6	CEL0205*S6HMA	9.00	9.00	9.00	-
6	CEL0240*S6HMA	9.00	9.00	9.00	-
6	CEL0255*S6HMA	9.00	9.00	9.00	-
6	CEL0310*S6HMA	9.00	9.00	9.00	-
4	CEL0045*S4HMA	9.00	9.00	9.00	-
4	CEL0070*S4HMA	9.00	9.00	9.00	-
4	CEL0090*S4HMA	9.00	9.00	9.00	-
4	CEL0135*S4HMA	9.00	9.00	9.00	-
4	CEL0180*S4HMA	9.00	9.00	9.00	-
4	CEL0220*S4HMA	9.00	9.00	9.00	-
4	CEL0275*S4HMA	9.00	9.00	9.00	-

FPI	Model	Freezer			
		R-404A/ R-507A	R-448A/ R-449A	R-407A/ R-407F	R-407C
		AWEF	AWEF	AWEF	AWEF
6	CEL0040*S6HMA	3.96	3.96	3.96	-
6	CEL0045*S6HMA	3.96	3.96	3.96	-
6	CEL0065*S6HMA	4.00	4.03	4.02	-
6	CEL0080*S6HMA	4.00	4.00	4.00	-
6	CEL0100*S6HMA	4.03	4.03	4.03	-
6	CEL0130*S6HMA	4.06	4.06	4.06	-
6	CEL0155*S6HMA	4.09	4.09	4.09	-
6	CEL0170*S6HMA	4.10	4.10	4.10	-
6	CEL0205*S6HMA	4.14	4.14	4.14	-
6	CEL0240*S6HMA	4.15	4.15	4.15	-
6	CEL0255*S6HMA	4.15	4.15	4.15	-
6	CEL0310*S6HMA	4.15	4.15	4.15	-
4	CEL0045*S4HMA	3.96	3.96	3.96	-
4	CEL0070*S4HMA	3.99	3.99	3.99	-
4	CEL0090*S4HMA	4.02	4.02	4.02	-
4	CEL0135*S4HMA	4.07	4.07	4.07	-
4	CEL0180*S4HMA	4.12	4.12	4.12	-
4	CEL0220*S4HMA	4.15	4.15	4.15	-
4	CEL0275*S4HMA	4.15	4.15	4.15	-

HOT GAS REVERSE CYCLE KITS

Shipped Loose Accessories

FPI	Model	TXV Bypass and Liquid Line Piping Kit (Reverse Cycle)	TXV Liquid Line Piping Kit (Three Pipe or Rev Cycle w/o TXV Bypass)	Suction/Drain Pan Check Valve Piping Kit (Reverse Cycle)	Drain Pan Check Valve Piping Kit (Three Pipe)
		For TXV's SBF/SQE/BBI/EG	For TXV's SBF/SQE/BBI/EG		
6	CEL0040*S6H^A	50756301	50756302	50692204	50692302
6	CEL0045*S6H^A	50756301	50756302	50692204	50692302
6	CEL0065*S6H^A	50756301	50756302	50692204	50692302
6	CEL0080*S6H^A	50756301	50756302	50692204	50692302
6	CEL0100*S6H^A	50756301	50756302	50692225	50692302
6	CEL0130*S6H^A	50756301	50756302	50692225	50692302
6	CEL0155*S6H^A	50756301	50756302	50692206	50692302
6	CEL0170*S6H^A	50756301	50756302	50692205	50692302
6	CEL0205*S6H^A	50756301	50756302	50692206	50692302
6	CEL0240*S6H^A	50756301	50756302	50692206	50692302
6	CEL0255*S6H^A	50756301	50756302	50692206	50692302
6	CEL0310*S6H^A	50756301	50756302	50692206	50692302
4	CEL0045*S4H^A	50756301	50756302	50692204	50692302
4	CEL0070*S4H^A	50756301	50756302	50692204	50692302
4	CEL0090*S4H^A	50756301	50756302	50692205	50692302
4	CEL0135*S4H^A	50756301	50756302	50692205	50692302
4	CEL0180*S4H^A	50756301	50756302	50692206	50692302
4	CEL0220*S4H^A	50756301	50756302	50692206	50692302
4	CEL0275*S4H^A	50756301	50756302	50692206	50692302

REVERSE CYCLE PIPING

Reverse cycle defrost unit cooler operation

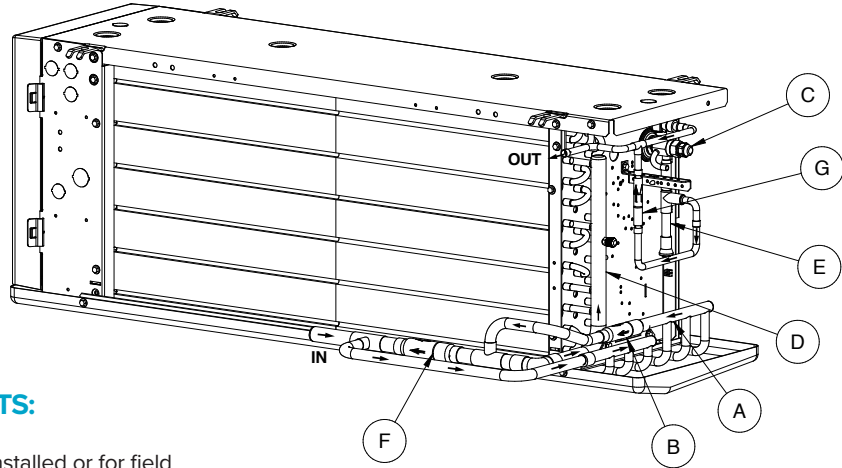
Reverse cycle defrost is a common method used in systems that include at least four unit coolers connected to a compressor rack. No more than 25% of the connected unit coolers are typically defrosted at the same time.

During reverse cycle, valving at the compressor rack diverts hot gas through the suction line to the defrosting unit cooler. See piping view in Figure 1. The suction line check valve directs the hot gas through the pan loop; heating the drain pan and preventing condensate from freezing during defrost. The hot gas exits the loop at the pan loop outlet header, passes through the drain pan check valve and enters the evaporator coil through the coil suction header. The hot refrigerant gas then flows through the defrosting coil, heating the finned surface and melting frost. As heat is transferred to the coil fins, hot refrigerant gas condenses to a liquid state. The refrigerant then exits the coil at the distributor side port, passes around the expansion valve through the bypass check valve and flows into the liquid refrigerant line. The liquid refrigerant then feeds other evaporators on the cooling cycle, evaporates, and returns to the compressor through their suction lines.

In some systems, electric drain pan heaters are used instead of a hot gas pan loop. Hot gas piping is simplified with the suction and drain pan check valves being eliminated. Electric drain pan heaters are energized during the defrost period, by a defrost control on the unit cooler or by a compressor rack controller.

REVERSE CYCLE DEFROST PIPING KEY COMPONENTS (FIG. 1)

- A. Hot gas drain pan loop
- B. Drain pan check valve
- C. Expansion valve
- D. Suction header
- E. Distributor
- F. Suction check valve
- G. Expansion valve bypass check valve



REVERSE CYCLE DEFROST PIPING KITS:

External check valve kit (available factory-installed or for field installation) includes suction check valve, drain pan check valve and piping to connect to suction header and hot gas drain pan loop. This kit is only necessary when the unit cooler is equipped with a hot gas drain pan loop.

Expansion valve bypass kit (available factory-installed or for field installation) includes expansion valve bypass check valve and piping to connect to the distributor side port and liquid line piping. The factory-installed version includes the expansion valve.

Use of external liquid/suction line heat exchanger with a reverse cycle system:

To increase the efficiency, higher performance and greater system protection, a heat exchanger may be beneficial to the system. In order to use a heat exchanger, the expansion valve bypass piping must be modified. See the piping view in Figure 2. The modification includes rerouting the pipe from the expansion valve bypass check valve to the inlet connection of the liquid line to the heat exchanger. A pipe needs to be routed from the liquid line outlet connection of the heat exchanger to the inlet connection of the thermostatic expansion valve.

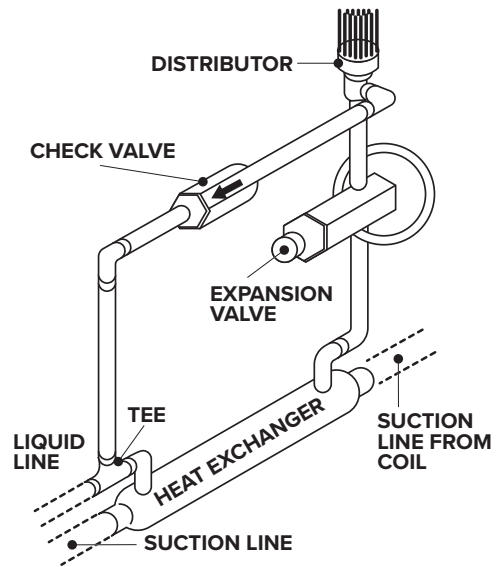


FIGURE 2. Typical Liquid Line Bypass Kit
(Shown assembled and modified for heat exchanger)

Three-pipe defrost unit cooler operation

Three-pipe defrost systems are connected to either a condensing unit or a compressor rack. No more than 33% of the connected unit coolers are typically defrosted at the same time.

During defrost, hot gas is directed through dedicated refrigerant piping (third pipe) to the defrosting unit cooler. See piping view in Figure 3. The hot gas enters the drain pan loop; heating the drain pan and preventing condensate from freezing during defrost. The hot gas exits the loop at the pan loop outlet header, passes through the drain pan check valve and enters the evaporator coil through the distributor side port connection. The hot refrigerant gas then flows through the defrosting coil, heating the finned surface and melting frost. As heat is transferred to the coil fins, hot refrigerant gas condenses to a liquid state. The refrigerant then exits the coil at the suction header.

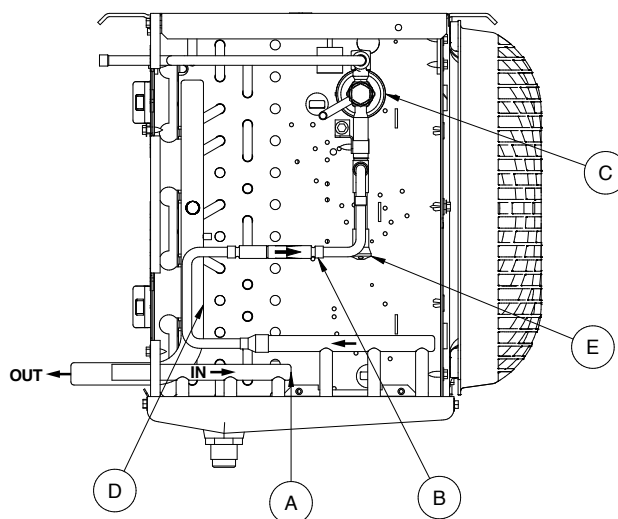
Three-pipe defrost unit cooler operation (cont.)

In some systems, electric drain pan heaters are used instead of a hot gas pan loop. Hot gas piping is simplified with the drain pan check valve being eliminated. Electric drain pan heaters are energized during the defrost period, by a defrost control on the unit cooler or by a compressor rack controller.

In order to provide sufficient re-evaporation of the liquid vapor mixture and sufficient heat for defrost, no more than one-third of the system should be defrosted at one time. Some means of control in the 3-pipe hot gas system should be supplied to regulate the large amount of liquid returning to the compressor, refrigerant slugging can otherwise damage the compressor.

REVERSE CYCLE THREE-PIPE DEFROST PIPING KEY COMPONENTS (FIG. 3)

- A. Hot gas drain pan loop
- B. Drain pan check valve
- C. Expansion valve
- D. Suction header
- E. Distributor



THREE-PIPE DEFROST PIPING KIT:

Three-pipe check valve kit (available factory-installed or for field installation) includes drain pan check valve and piping to connect the distributor side port to the hot gas drain pan loop. This kit is only necessary when the unit cooler is equipped with a hot gas drain pan loop.

Hot gas defrost controls:

Hot gas unit coolers are factory equipped with temperature control(s) that terminate the defrost cycle when the evaporator coil is clear of frost. After defrost, the control(s) keep the evaporator fans from re-energizing until the coil temperature is close to the freezing point.

STANDARD:

The standard control scheme includes an electromechanical defrost termination / fan delay control.

For reverse cycle defrost, the control sensing bulb is placed on the expansion valve bypass line, between the distributor side port and the expansion valve bypass check valve.

For three-pipe defrost, the control sensing bulb is placed on the suction header or suction header outlet connection.

OPTIONAL:

The optional control scheme includes an electromechanical defrost termination control and a separate bimetallic fan delay control. This scheme provides more options for the placement of the control sensing bulb as the defrost termination and fan delay sensing points are no longer combined.

The fan delay temperature is sensed on the evaporator coil endplate adjacent to the fins.

For reverse cycle defrost, the control sensing bulb is placed on the expansion valve bypass line or liquid line piping adjacent to the unit cooler.

For three-pipe defrost, the control sensing bulb is placed on the suction header or suction header outlet connection.

REPLACEMENT PARTS

Motor/Motor Mounts

Part #	Motor Type	Voltage	Motor Speeds	Motor Mount
25312501S / 25329001S	EC	115	1-SP / 2-SP	23108401*
25312601S / 25329101S	EC	208-230	2-SP	23108401*
25317701S	EC	208-230	1-SP	23108401
25309501S	PSC	115	1-SP	23108401
25309801S	PSC	208-230	1-SP	23108401
25309701S	PSC	460	1-SP	23106401

* = Consult factory when replacing motor mounts for motors 25329001S / 23529101S

Fan Blade

Part #	Description
5140C	Fan Blade 12" Std
5110E	Fan Blade 12" Reverse Air Flow

Fan Guard

Part #	Description
37001601	Fan Guard Wire Blue
37001801	Fan Guard Molded Blue

Cabinet Components

Part #	No. of Fans	Description	Defrost Type	Cabinet Aluminum	Application Notes
40594101	1	Drain Pan	Air/Hot Gas	Aluminum	Air, Hot Gas Models w/Drain Pan Loop
40595101	1	Drain Pan	Air/Hot Gas	White Painted Aluminum	Air, Hot Gas Models w/Drain Pan Loop
40596101	1	Drain Pan	Air/Hot Gas	Stainless Steel	Air Defrost Only
40594201	2	Drain Pan	Air/Hot Gas	Aluminum	Air, Hot Gas Models w/Drain Pan Loop
40595201	2	Drain Pan	Air/Hot Gas	White Painted Aluminum	Air, Hot Gas Models w/Drain Pan Loop
40596201	2	Drain Pan	Air/Hot Gas	Stainless Steel	Air Defrost Only
40594301	3	Drain Pan	Air/Hot Gas	Aluminum	Air, Hot Gas Models w/Drain Pan Loop
40595301	4	Drain Pan	Air/Hot Gas	White Painted Aluminum	Air, Hot Gas Models w/Drain Pan Loop
40596301	4	Drain Pan	Air/Hot Gas	Stainless Steel	Air Defrost Only
40594401	4	Drain Pan	Air/Hot Gas	Aluminum	Air, Hot Gas Models w/Drain Pan Loop
40595401	4	Drain Pan	Air/Hot Gas	White Painted Aluminum	Air, Hot Gas Models w/Drain Pan Loop
40596401	4	Drain Pan	Air/Hot Gas	Stainless Steel	Air Defrost Only
40594501	5	Drain Pan	Air/Hot Gas	Aluminum	Air, Hot Gas Models w/Drain Pan Loop
40595501	5	Drain Pan	Air/Hot Gas	White Painted Aluminum	Air, Hot Gas Models w/Drain Pan Loop
40596501	5	Drain Pan	Air/Hot Gas	Stainless Steel	Air Defrost Only
40594601	6	Drain Pan	Air/Hot Gas	Aluminum	Air, Hot Gas Models w/Drain Pan Loop
40595601	6	Drain Pan	Air/Hot Gas	White Painted Aluminum	Air, Hot Gas Models w/Drain Pan Loop
40596601	6	Drain Pan	Air/Hot Gas	Stainless Steel	Air Defrost Only

REPLACEMENT PARTS

Cabinet Components (cont.)

Part #	No. of Fans	Description	Defrost Type	Cabinet Aluminum	Application Notes
40594102	1	Drain Pan	Electric/Hot Gas	Aluminum	Elec, Hot Gas Models w/Drain Pan Heater
40595102	1	Drain Pan	Electric/Hot Gas	White Painted Aluminum	Elec, Hot Gas Models w/Drain Pan Heater
40594202	2	Drain Pan	Electric/Hot Gas	Aluminum	Elec, Hot Gas Models w/Drain Pan Heater
40595202	2	Drain Pan	Electric/Hot Gas	White Painted Aluminum	Elec, Hot Gas Models w/Drain Pan Heater
40594302	3	Drain Pan	Electric/Hot Gas	Aluminum	Elec, Hot Gas Models w/Drain Pan Heater
40595302	3	Drain Pan	Electric/Hot Gas	White Painted Aluminum	Elec, Hot Gas Models w/Drain Pan Heater
40594402	4	Drain Pan	Electric/Hot Gas	Aluminum	Elec, Hot Gas Models w/Drain Pan Heater
40595402	4	Drain Pan	Electric/Hot Gas	White Painted Aluminum	Elec, Hot Gas Models w/Drain Pan Heater
40594502	5	Drain Pan	Electric/Hot Gas	Aluminum	Elec, Hot Gas Models w/Drain Pan Heater
40595502	5	Drain Pan	Electric/Hot Gas	White Painted Aluminum	Elec, Hot Gas Models w/Drain Pan Heater
40594602	6	Drain Pan	Electric/Hot Gas	Aluminum	Elec, Hot Gas Models w/Drain Pan Heater
40595602	6	Drain Pan	Electric/Hot Gas	White Painted Aluminum	Elec, Hot Gas Models w/Drain Pan Heater
40593703	1	Insulated Outer Drain Pan Assy	All	Aluminum	Includes Outer Cover and Insulation
40593704	1	Insulated Outer Drain Pan Assy	All	White Painted Aluminum	Includes Outer Cover and Insulation
40593002	1	Insulated Outer Drain Pan Assy	All	Stainless Steel	Includes Outer Cover and Insulation
40593803	2	Insulated Outer Drain Pan Assy	All	Aluminum	Includes Outer Cover and Insulation
40593804	2	Insulated Outer Drain Pan Assy	All	White Painted Aluminum	Includes Outer Cover and Insulation
40593102	2	Insulated Outer Drain Pan Assy	All	Stainless Steel	Includes Outer Cover and Insulation
40591503	3	Insulated Outer Drain Pan Assy	All	Aluminum	Includes Outer Cover and Insulation
40591504	3	Insulated Outer Drain Pan Assy	All	White Painted Aluminum	Includes Outer Cover and Insulation
40593202	3	Insulated Outer Drain Pan Assy	All	Stainless Steel	Includes Outer Cover and Insulation
40591603	4	Insulated Outer Drain Pan Assy	All	Aluminum	Includes Outer Cover and Insulation
40591604	4	Insulated Outer Drain Pan Assy	All	White Painted Aluminum	Includes Outer Cover and Insulation
40593302	4	Insulated Outer Drain Pan Assy	All	Stainless Steel	Includes Outer Cover and Insulation
40591703	5	Insulated Outer Drain Pan Assy	All	Aluminum	Includes Outer Cover and Insulation
40591704	5	Insulated Outer Drain Pan Assy	All	White Painted Aluminum	Includes Outer Cover and Insulation
40593402	5	Insulated Outer Drain Pan Assy	All	Stainless Steel	Includes Outer Cover and Insulation
40591803	6	Insulated Outer Drain Pan Assy	All	Aluminum	Includes Outer Cover and Insulation

REPLACEMENT PARTS

Cabinet Components (cont.)

Part #	No. of Fans	Description	Defrost Type	Cabinet Aluminum	Application Notes
40591804	6	Insulated Outer Drain Pan Assy	All	White Painted Aluminum	Includes Outer Cover and Insulation
40593502	6	Insulated Outer Drain Pan Assy	All	Stainless Steel	Includes Outer Cover and Insulation
41032901	All	Access Panel RH (Elect) End	All	Aluminum/Stainless Steel	All w/Unpainted Cabinet
41032902	All	Access Panel RH (Elect) End	All	White Painted Aluminum	All w/White Cabinet
41032801	All	Access Panel LH (Refrig) End	All	Aluminum/Stainless Steel	Standard w/Unpainted Cabinet
41032802	All	Access Panel LH (Refrig) End	All	White Painted Aluminum	Standard w/White Cabinet
41032803	All	Access Panel LH (Refrig) End	Air/Electric	Aluminum/Stainless Steel	IntelliGen/QRC/Beacon II w/Unpainted Cabinet
41032804	All	Access Panel LH (Refrig) End	Air/Electric	White Painted Aluminum	IntelliGen/QRC/Beacon II w/White Cabinet
41038401	All	Access Panel LH (Refrig) End	Air/Electric	Aluminum	Glycol/CO ₂ Overfeed Only
41038402	All	Access Panel LH (Refrig) End	Air/Electric	White Painted Aluminum	Glycol/CO ₂ Overfeed Only
41038501	All	Access Panel LH (Refrig) End	Air/Electric	Stainless Steel	Glycol/CO ₂ Overfeed Only
41038701	All	Access Panel RH (Elect) End	Air/Electric	Aluminum	Glycol/CO ₂
41038702	All	Access Panel RH (Elect) End	Air/Electric	White Painted Aluminum	Glycol/CO ₂
41038901	All	Access Panel RH (Elect) End	Air/Electric	Stainless Steel	Glycol/CO ₂

Drain Pan Heaters

Part #	No. of Fans	Voltage	Wattage	Defrost Type	Application Notes
24753101	1	115	150	Hot Gas	Hot Gas Models w/Drain Pan Heater
24753102	2	115	300	Hot Gas	Hot Gas Models w/Drain Pan Heater
24753103	3	115	450	Hot Gas	Hot Gas Models w/Drain Pan Heater
24753104	4	115	600	Hot Gas	Hot Gas Models w/Drain Pan Heater
24753105	5	115	750	Hot Gas	Hot Gas Models w/Drain Pan Heater
24753106	6	115	900	Hot Gas	Hot Gas Models w/Drain Pan Heater
24752501	1	230	150	Electric /Hot Gas	Elec, Hot Gas Models w/Drain Pan Heater
24752502	2	230	300	Electric /Hot Gas	Elec, Hot Gas Models w/Drain Pan Heater
24752503	3	230	450	Electric /Hot Gas	Elec, Hot Gas Models w/Drain Pan Heater
24752504	4	230	600	Electric /Hot Gas	Elec, Hot Gas Models w/Drain Pan Heater
24752505	5	230	750	Electric /Hot Gas	Elec, Hot Gas Models w/Drain Pan Heater
24752506	6	230	900	Electric /Hot Gas	Elec, Hot Gas Models w/Drain Pan Heater
24753201	1	460	150	Hot Gas	Hot Gas Models w/Drain Pan Heater
24753202	2	460	300	Hot Gas	Hot Gas Models w/Drain Pan Heater
24753203	3	460	450	Hot Gas	Hot Gas Models w/Drain Pan Heater
24753204	4	460	600	Hot Gas	Hot Gas Models w/Drain Pan Heater
24753205	5	460	750	Hot Gas	Hot Gas Models w/Drain Pan Heater
24753206	6	460	900	Hot Gas	Hot Gas Models w/Drain Pan Heater

REPLACEMENT PARTS

Coil Defrost Heaters

Part #	No. of Fans	Voltage	Wattage	Defrost Type
24752001	1	230	300	Electric
24752002	2	230	600	Electric
24752003	3	230	900	Electric
24752004	4	230	1,200	Electric
24752005	5	230	1,500	Electric
24752006	6	230	1,800	Electric
24754101*	1	230	150	Electric
24754102*	2	230	300	Electric
24754103*	3	230	450	Electric
24754104*	4	230	600	Electric
24754105*	5	230	750	Electric
24754106*	6	230	900	Electric

* = One used per 460V unit only, top coil heater position

Electrical Components

Part #	Description	Defrost Type	Application Notes
22597101	Terminal Board	Air	All
22597701	Terminal Board	Electric/Hot Gas	All
5709L	Defrost Termination/Fan Delay Thermostat	Electric	Fixed Bi-Metallic Control
5708L	Heater Limit Thermostat	Electric	Fixed Bi-Metallic Control
4267W	Defrost Termination/Fan Delay Thermostat	Electric/Hot Gas	Adjustable Control
28913901	Room Thermostat	Air/Electric	Room Thermostat Mech
28963201	Room Thermostat	Air/Electric	Room Thermostat Elec

Drain Fitting

Part #	Description	Application Notes
26925101	Drain Fitting Kit	All

STANDARD NOZZLE SELECTION

Air Defrost

Medium Temperature (25°F SST)								
Model	No. of Fans	Distributor Tube (in.)		No. of Circuits	Nozzle Selections			
		OD	Length		R-404A/R-507A	R-448A/R-449A	R-407A/R-407F	R-407C
CEL0045*S6A^A	1	3/16	15	1	-	-	-	-
CEL0055*S6A^A	1	3/16	15	2	L-1/3	L-1/2	L-1/3	L-1/3
CEL0060*S6A^A	1	3/16	15	2	L-1/2	L-3/4	L-1/2	L-1/2
CEL0095*S6A^A	2	3/16	15	2	L-1/2	L-3/4	L-1/2	L-1/2
CEL0105*S6A^A	2	3/16	15	3	L-3/4	L-1	L-3/4	L-3/4
CEL0115*S6A^A	2	3/16	15	4	L-1	L-1-1/2	L-1	L-1
CEL0125*S6A^A	2	3/16	15	4	L-1	L-1-1/2	L-1	L-1
CEL0155*S6A^A	3	3/16	15	4	L-1	L-1-1/2	L-1	L-1
CEL0190*S6A^A	3	3/16	15	6	L-1-1/2	L-2	L-1-1/2	L-1-1/2
CEL0250*S6A^A	4	3/16	15	6	L-1-1/2	L-2	L-1-1/2	L-1-1/2
CEL0295*S6A^A	5	3/16	15	6	L-2	L-2-1/2	L-1-1/2	L-1-1/2
CEL0350*S6A^A	6	3/16	15	7	L-2	L-3	L-2	L-2
CEL0380*S6A^A	6	3/16	15	8	L-2-1/2	L-3	L-2-1/2	L-2-1/2

Notes:

Nozzles sized for 90-100°F liquid temperature at expansion valve.
 Contact Application Engineering for guidance if:
 - Liquid temperature is not 90-100°F
 - Evaporator TD is not 10°-15°F (room temperature – saturated suction temperature)
 Caution: Refrigeration system will not perform properly without correct nozzle

STANDARD NOZZLE SELECTION

Electric Defrost

Low Temperature (-20°F SST)								
Model	No. of Fans	Distributor Tube (in.)		No. of Circuits	Nozzle Selections			
		OD	Length		R-404A/R-507A	R-448A/R-449A	R-407A/R-407F	R-407C
CEL0040*S6E^A	1	3/16	15	2	L-1/2	L-3/4	L-1/2	-
CEL0045*S6E^A	1	3/16	15	2	L-3/4	L-3/4	L-1/2	-
CEL0065*S6E^A	2	3/16	15	3	L-3/4	L-1	L-3/4	-
CEL0080*S6E^A	2	3/16	15	3	L-1	L-1-1/2	L-1	-
CEL0100*S6E^A	2	3/16	15	6	L-1-1/2	L-1-1/2	L-1	-
CEL0130*S6E^A	3	3/16	15	6	L-1-1/2	L-2	L-1-1/2	-
CEL0155*S6E^A	3	3/16	15	8	L-2	L-2-1/2	L-2	-
CEL0170*S6E^A	4	3/16	15	6	L-2	L-2-1/2	L-2	-
CEL0205*S6E^A	4	3/16	15	8	L-2-1/2	L-3	L-2	-
CEL0240*S6E^A	5	3/16	15	8	L-2-1/2	L-4	L-2-1/2	-
CEL0255*S6E^A	6	3/16	15	9	L-3	L-4	L-3	-
CEL0310*S6E^A	6	3/16	15	12	L-4	L-5	L-3	-
CEL0045*S4E^A	1	3/16	15	2	L-1/2	L-3/4	L-1/2	-
CEL0070*S4E^A	2	3/16	15	3	L-3/4	L-1	L-3/4	-
CEL0090*S4E^A	2	3/16	15	6	L-1	L-1-1/2	L-1	-
CEL0135*S4E^A	3	3/16	15	6	L-1-1/2	L-2	L-1-1/2	-
CEL0180*S4E^A	4	3/16	15	8	L-2	L-2-1/2	L-2	-
CEL0220*S4E^A	5	3/16	15	8	L-2	L-3	L-2	-
CEL0275*S4E^A	6	3/16	15	12	L-3	L-4	L-3	-

Medium Temperature (25°F SST)								
Model	No. of Fans	Distributor Tube (in.)		No. of Circuits	Nozzle Selections			
		OD	Length		R-404A/R-507A	R-448A/R-449A	R-407A/R-407F	R-407C
CEL0040*S6E^A	1	3/16	15	2	L-1/4	L-1/3	L-1/4	L-1/4
CEL0045*S6E^A	1	3/16	15	2	L-1/3	L-1/2	L-1/3	L-1/3
CEL0065*S6E^A	2	3/16	15	3	L-1/2	L-3/4	L-1/2	L-1/2
CEL0080*S6E^A	2	3/16	15	3	L-3/4	L-3/4	L-1/2	L-1/2
CEL0100*S6E^A	2	3/16	15	6	L-3/4	L-1	L-3/4	L-3/4
CEL0130*S6E^A	3	3/16	15	6	L-1	L-1-1/2	L-1	L-1
CEL0155*S6E^A	3	3/16	15	8	L-1	L-1-1/2	L-1	L-1
CEL0170*S6E^A	4	3/16	15	6	L-1-1/2	L-1-1/2	L-1-1/2	L-1-1/2
CEL0205*S6E^A	4	3/16	15	8	L-1-1/2	L-2	L-1-1/2	L-1-1/2
CEL0240*S6E^A	5	3/16	15	8	L-1-1/2	L-2	L-1-1/2	L-1-1/2
CEL0255*S6E^A	6	3/16	15	9	L-2	L-2-1/2	L-2	L-2
CEL0310*S6E^A	6	3/16	15	12	L-2	L-3	L-2	L-2
CEL0045*S4E^A	1	3/16	15	2	L-1/3	L-1/2	L-1/4	L-1/4
CEL0070*S4E^A	2	3/16	15	3	L-1/2	L-3/4	L-1/2	L-1/2
CEL0090*S4E^A	2	3/16	15	6	L-3/4	L-3/4	L-3/4	L-3/4
CEL0135*S4E^A	3	3/16	15	6	L-3/4	L-1	L-3/4	L-3/4
CEL0180*S4E^A	4	3/16	15	8	L-1	L-1-1/2	L-1	L-1
CEL0220*S4E^A	5	3/16	15	8	L-1-1/2	L-2	L-1-1/2	L-1-1/2
CEL0275*S4E^A	6	3/16	15	12	L-2	L-2-1/2	L-2	L-2

Notes:

Nozzles sized for 90-100°F liquid temperature at expansion valve.
 Contact Application Engineering for guidance if:
 - Liquid temperature is not 90-100°F
 - Evaporator TD is not 10°-15°F (room temperature – saturated suction temperature)
 Caution: Refrigeration system will not perform properly without correct nozzle

STANDARD NOZZLE SELECTION

Hot Gas Defrost

Low Temperature (-20°F SST)

Model	No. of Fans	Distributor Tube (in.)		No. of Circuits	Nozzle Selections			
		OD	Length		R-404A/R-507A	R-448A/R-449A	R-407A/R-407F	R-407C
CEL0040*S6H^A	1	3/16	15	2	L-1/2	L-3/4	L-1/2	-
CEL0045*S6H^A	1	3/16	15	2	L-3/4	L-3/4	L-1/2	-
CEL0065*S6H^A	2	3/16	15	3	L-3/4	L-1	L-3/4	-
CEL0080*S6H^A	2	3/16	15	3	L-1	L-1-1/2	L-1	-
CEL0100*S6H^A	2	3/16	15	6	L-1-1/2	L-1-1/2	L-1	-
CEL0130*S6H^A	3	3/16	15	6	L-1-1/2	L-2	L-1-1/2	-
CEL0155*S6H^A	3	3/16	15	8	L-2	L-2-1/2	L-2	-
CEL0170*S6H^A	4	3/16	15	6	L-2	L-2-1/2	L-2	-
CEL0205*S6H^A	4	3/16	15	8	L-2-1/2	L-3	L-2	-
CEL0240*S6H^A	5	3/16	15	8	L-2-1/2	L-4	L-2-1/2	-
CEL0255*S6H^A	6	3/16	15	9	L-3	L-4	L-3	-
CEL0310*S6H^A	6	3/16	15	12	L-4	L-5	L-3	-
CEL0045*S4H^A	1	3/16	15	2	L-1/2	L-3/4	L-1/2	-
CEL0070*S4H^A	2	3/16	15	3	L-3/4	L-1	L-3/4	-
CEL0090*S4H^A	2	3/16	15	6	L-1	L-1-1/2	L-1	-
CEL0135*S4H^A	3	3/16	15	6	L-1-1/2	L-2	L-1-1/2	-
CEL0180*S4H^A	4	3/16	15	8	L-2	L-2-1/2	L-2	-
CEL0220*S4H^A	5	3/16	15	8	L-2	L-3	L-2	-
CEL0275*S4H^A	6	3/16	15	12	L-3	L-4	L-3	-

Medium Temperature (25°F SST)

Model	No. of Fans	Distributor Tube (in.)		No. of Circuits	Nozzle Selections			
		OD	Length		R-404A/R-507A	R-448A/R-449A	R-407A/R-407F	R-407C
CEL0040*S6H^A	1	3/16	15	2	L-1/4	L-1/3	L-1/4	L-1/4
CEL0045*S6H^A	1	3/16	15	2	L-1/3	L-1/2	L-1/3	L-1/3
CEL0065*S6H^A	2	3/16	15	3	L-1/2	L-3/4	L-1/2	L-1/2
CEL0080*S6H^A	2	3/16	15	3	L-3/4	L-3/4	L-1/2	L-1/2
CEL0100*S6H^A	2	3/16	15	6	L-3/4	L-1	L-3/4	L-3/4
CEL0130*S6H^A	3	3/16	15	6	L-1	L-1-1/2	L-1	L-1
CEL0155*S6H^A	3	3/16	15	8	L-1	L-1-1/2	L-1	L-1
CEL0170*S6H^A	4	3/16	15	6	L-1-1/2	L-1-1/2	L-1-1/2	L-1-1/2
CEL0205*S6H^A	4	3/16	15	8	L-1-1/2	L-2	L-1-1/2	L-1-1/2
CEL0240*S6H^A	5	3/16	15	8	L-1-1/2	L-2	L-1-1/2	L-1-1/2
CEL0255*S6H^A	6	3/16	15	9	L-2	L-2-1/2	L-2	L-2
CEL0310*S6H^A	6	3/16	15	12	L-2	L-3	L-2	L-2
CEL0045*S4H^A	1	3/16	15	2	L-1/3	L-1/2	L-1/4	L-1/4
CEL0070*S4H^A	2	3/16	15	3	L-1/2	L-3/4	L-1/2	L-1/2
CEL0090*S4H^A	2	3/16	15	6	L-3/4	L-3/4	L-3/4	L-3/4
CEL0135*S4H^A	3	3/16	15	6	L-3/4	L-1	L-3/4	L-3/4
CEL0180*S4H^A	4	3/16	15	8	L-1	L-1-1/2	L-1	L-1
CEL0220*S4H^A	5	3/16	15	8	L-1-1/2	L-2	L-1-1/2	L-1-1/2
CEL0275*S4H^A	6	3/16	15	12	L-2	L-2-1/2	L-2	L-2

Notes:

Nozzles sized for 90-100°F liquid temperature at expansion valve.
 Contact Application Engineering for guidance if:
 - Liquid temperature is not 90-100°F
 - Evaporator TD is not 10°-15°F (room temperature – saturated suction temperature)
 Caution: Refrigeration system will not perform properly without correct nozzle



2175 West Park Place Blvd.

Stone Mountain, GA 30087

Phone: 800.537.7775 · Fax: 770.465.5900

heatcraftprd.com

Since product improvement is a continuing effort, we reserve the right to make changes in specifications without notice.

CC-LOP-0622 | Version 004

©2022 Heatcraft Refrigeration Products LLC

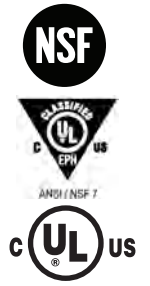
LOW PROFILE UNIT COOLERS

Technical Guide
Including models meeting DOE minimum AWEF

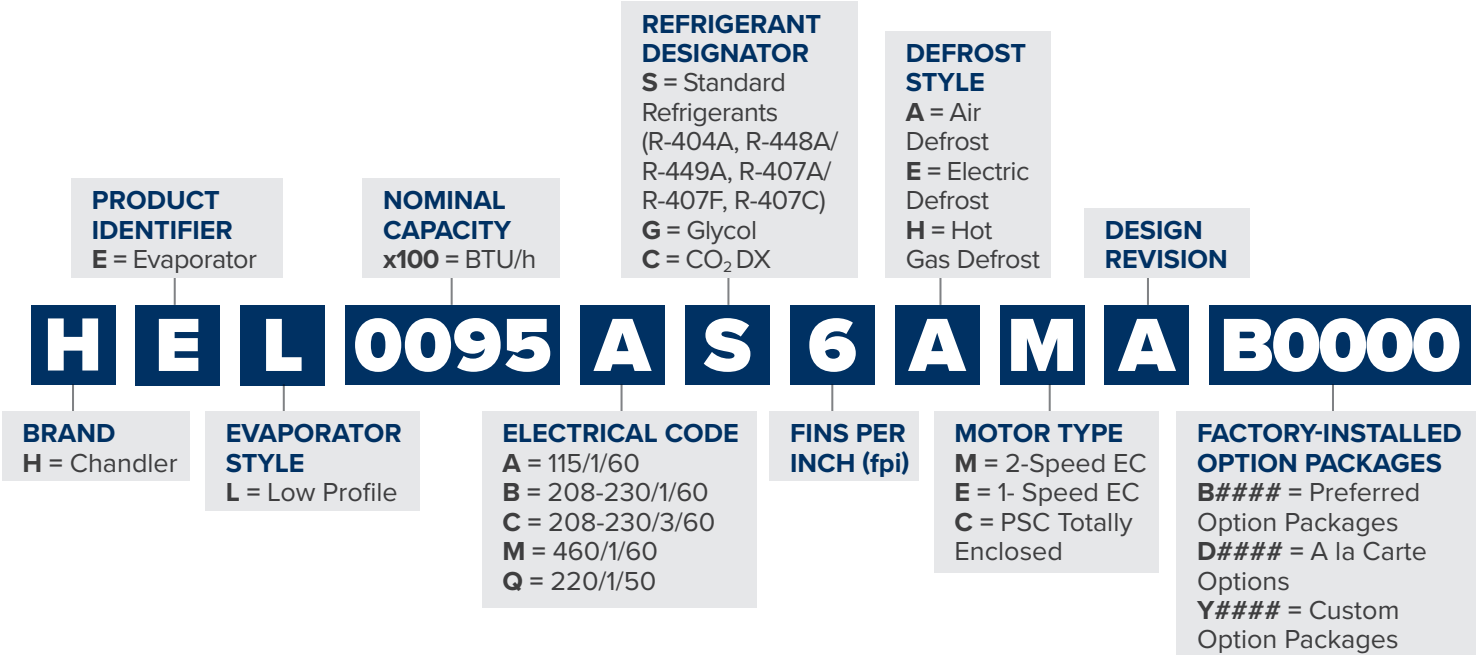


TABLE OF CONTENTS

3	Nomenclature
3	Preferred Option Packages
5	Features & Benefits
7	Air Defrost
7	Performance Data
7	Application Capacity: Air Defrost- 60 Hz
8	Application Capacity: Air Defrost- 60 Hz (CO ₂ DX)
9	Application Capacity: Air Defrost- 50 Hz (For PSC Motors) †
10	Application Capacity: Air Defrost- 50 Hz (CO ₂ DX)
11	Unit Specifications
14	Electric Defrost
14	Performance Data
14	Application Capacity: Low Temperature Electric Defrost- 60 Hz
16	Application Capacity: Low Temperature Electric Defrost- 60 Hz (CO ₂ DX)
17	Application Capacity: Low Temperature Electric Defrost- 50 Hz (For PSC Motors) †
19	Application Capacity: Low Temperature Electric Defrost- 50 Hz (CO ₂ DX)
20	Application Capacity: Medium Temperature Electric Defrost- 60 Hz
22	Application Capacity: Medium Temperature Electric Defrost- 60 Hz (CO ₂ DX)
23	Unit Specifications
	Hot Gas Defrost
27	Performance Data
27	Application Capacity: Low Temperature Hot Gas Defrost- 60 Hz
29	Application Capacity: Low Temperature Hot Gas Defrost- 50 Hz (For PSC Motors) †
31	Application Capacity: Medium Temperature Hot Gas Defrost- 60 Hz
33	Unit Specifications
39	Physical Data
42	Dimensional Drawings
	DOE Rated AWEF
43	AWEF
43	Air Defrost 2-Speed EC Motors
44	Electric Defrost 1-Speed EC Motors
45	Electric Defrost 2-Speed EC Motors
46	Hot Gas Defrost 1-Speed EC Motors
47	Hot Gas Defrost 2-Speed EC Motors
48	Hot Gas Defrost Reverse Cycle
48	Hot Gas Reverse Cycle Kits
48	Reverse Cycle Piping
51	Replacement Parts
51	Motor/Motor Mounts
51	Fan Blade/Fan Guard
51	Cabinet Components
53	Drain Pan Heaters
53	Coil Defrost Heaters
53	Electrical Components
53	Drain Fitting
55	Standard Nozzle Selection
55	Air Defrost
56	Electric Defrost
57	Hot Gas Defrost



NOMENCLATURE



PREFERRED OPTION PACKAGES

(HFC Refrigerants)

Package	Description (standard base model features + indicated options below)
B0000	Standard Base
B0100	Beacon II (R-404A/R-448A/R-449A)
B0101	Beacon II (R-407A/R-407C/R-407F)
B0200	intelliGen Refrigeration Controller (R-404A/R-448A/R-449A)
B0201	intelliGen Refrigeration Controller (R-407A/R-407C/R-407F)
B0300	Quick Response Controller (R-404A/R-448A/R-449A)
B0301	Quick Response Controller (R-407A/R-407C/R-407F)
B0403	Mounted Components (TXV, Solenoid Valve, Electronic T'Stat – R-404A)
B0404	Mounted Components (TXV, Solenoid Valve, Electronic T'Stat – R-407A/C/F)
B0405	Mounted Components (TXV, Solenoid Valve, Electronic T'Stat – R-448A/R-449A)

PREFERRED OPTION PACKAGES

(CO₂ DX)

Package	Description (standard base model features + indicated options below)
B0500 Standard Base	Danfoss EEV (120V) with 1/4" MPT Transducer Connection (Pressure Transducer not included)
B0501	Danfoss EEV (120V) with 1/4" MPT Transducer Connection (Pressure Transducer not included) + Filter Drier
B0502	Sporlan EEV (120V) with 1/4" MPT Transducer Connection (Pressure Transducer not included) + Filter Drier
B0503	Danfoss EEV (120V) with Danfoss Pressure Transducer
B0504	Danfoss EEV (120V) with Danfoss Pressure Transducer + Filter Drier
B0505	Danfoss EEV (120V) with CPC Pressure Transducer
B0506	Danfoss EEV (120V) with CPC Pressure Transducer + Filter Drier
B0507	Sporlan EEV (120V) with Microthermo Pressure Transducer + Filter Drier

FEATURES & BENEFITS

CABINET

- Cabinet design features hinged, removable front access panels on each side for easy access to electrical and refrigeration components.
- Molded fan guard and access panels are made of strong, durable, NSF and UL Sanitation rated lightweight and damage-resistant molded plastic material.
- Quick-removal fan guard/motor assembly for easier servicing of air mover parts.
- Sweat connections to reduce potential for leaks.
- Liquid line solenoid wire harness is factory-installed for quick installation.

COIL

- Internally enhanced tubing and fin design for higher efficiency.
- Coil heater slots have been enlarged for easier installation and replacement.
- Hot gas loop on bottom of coil for easier access is standard on hot gas defrost models.
- Fixed defrost termination for electric, adjustable defrost termination for hot gas.

CONTROLS OPTIONS

- **intelliGen™ Refrigeration Controller (iRC)**
 - Factory mounted, tested and calibrated with an electronic expansion valve, pressure transducer, temperature sensors, control board and User Interface. Standard features include Door Sensor, Product Load Input and Alarm Output.
 - Optional Field installable intelliGen™ Webserver Card (iWC) enables local and remote monitoring on any smart phone, tablet or PC.
 - Optional Field installable intelliGen™ Integration Card (iIC) enables connectivity to BACnet and Modbus.
- **Quick Response Controller** units include factory mounted electronic expansion valve, pressure transducer, temperature sensors and control board.
- **Beacon II™** units include factory mounted electronic expansion valve, pressure transducer, temperature sensors and control board.

MOTORS

- Motors plug into wiring harness for easier servicing.
- 2-Speed EC motors standard on Air Defrost models.
- 1-Speed EC motors standard on Electric Defrost & Hot Gas Defrost models.

DRAIN PAN

- Large diameter drain hole (3/4" ID) is located towards the back of the unit.
- Extended drain pan heaters for more uniform defrost throughout the drain pan and additional heat in end compartments.
- Hinged, removable drain pans allow for easy and safe access (3-6 fan units only).

OTHER OPTIONS

- Units available with factory installed mounted components: Expansion Valve, Mechanical Room Thermostat, Solenoid Valve with Dual Voltage Coil.
- Units available with mounted TXV and mounted TXV with solenoid valve.
 - Pre-assembled units come with mounted TXV, liquid line solenoid valve and room thermostat.
 - Available in a master liquid line configuration.
 - Pre-charged units come with mounted TXV, liquid line solenoid valve, room thermostat and quick connect fittings.
- Units available with stainless steel housing and drain pan.
- All units come standard with aluminum fin, copper tube coils. Units available with various coil material / coating options including polyester fin coating, black electrostatic fin coating, copper fins and Bronz-Glow coil coating. Please review our price book for availability.
- Units available with insulated drain pan.

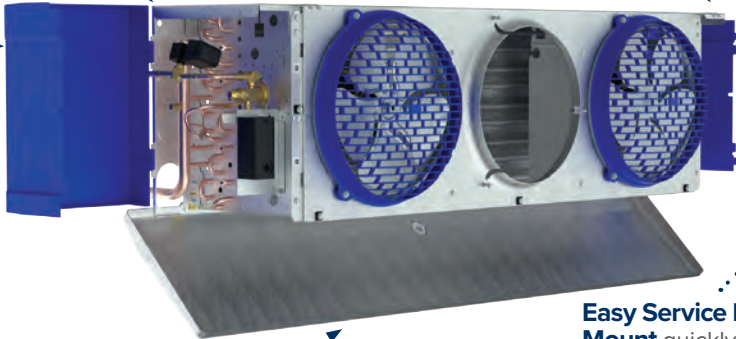
FEATURES & BENEFITS

OUTSTANDING FEATURES

Optional Factory Mounted Components
 Choose from Heatcraft's industry-leading IntelliGen™ Refrigeration Controller, Quick Response Controller, Beacon II Control or traditional mechanical components.

Composite Molded Access Panels have undergone extensive engineering and laboratory testing to ensure they are damage resistant from drops, dents, and bangs.

Hinged & Removeable Access Panels allow for easy access to both refrigeration and electrical end of Low Profile units.



Hinged Drain Pan improves access to service and clean the drain pan and coil. (3-6 fan models only)

Easy Service Motor Mount quickly and easily allows motor to be removed for service or replacement.

Re-Engineered Fan Guards have been redesigned for optimized air circulation and comply to new UL60335 safety standard.

Table 1: Capacity Correction Factors

Electric and Hot Gas Defrost Units				
Saturated Suction Temperature °F	+20	-10	-20	-30
Saturated Suction Temperature °C	-7	-23	-29	-34
Multiply Capacity By	1.15	1.04	1.00	0.90

PERFORMANCE DATA

Application Capacity: Air Defrost- 60 Hz

Please consult AWEF table on page 43 to confirm model meets DOE minimum AWEF

507A New Model	Legacy Model	R-404A/R-507A		R-448A/R-449A		Fan Data		
		Application Capacity ¹		Application Capacity ¹				
		10°F TD/25°F SST	6°C TD/-4°C SST	10°F TD/25°F SST	6°C TD/-4°C SST	No. of Fans	CFM	m ³ H
		BTUH	Watts	BTUH	Watts			
HEL0045*S6A^A	RLC040	4,000	1,200	4,600	1,300	1	653	1,109
HEL0055*S6A^A	RLC052	5,200	1,500	6,100	1,800	1	610	1,036
HEL0060*S6A^A	RLC065 RLC070	6,500	1,900	7,800	2,300	1	610	1,036
HEL0095*S6A^A	RLC070 RLC090	8,000	2,300	10,000	2,900	2	1,305	2,217
HEL0105*S6A^A	RLC090 RLC104	9,200	2,650	12,500	3,600	2	1,305	2,217
HEL0115*S6A^A	RLC120	11,700	3,370	14,500	4,180	2	1,220	2,073
HEL0125*S6A^A	RLC130	13,000	3,800	15,500	4,500	2	1,220	2,073
HEL0155*S6A^A	RLC140	14,000	4,100	16,800	4,900	3	1,958	3,327
HEL0190*S6A^A	RLC156 RLC180	18,000	5,300	21,200	6,200	3	1,830	3,109
HEL0250*S6A^A	RLC208	20,800	6,100	24,600	7,200	4	2,440	4,146
HEL0295*S6A^A	RLC260	26,000	7,600	30,700	9,000	5	3,050	5,182
HEL0350*S6A^A	RLC312	31,200	9,100	36,800	10,800	6	3,660	6,218
HEL0380*S6A^A	RLC370	37,000	10,800	44,400	13,000	6	3,660	6,218

New Model	Legacy Model	R-407A/R-407F		R-407C		Fan Data		
		Application Capacity ¹		Application Capacity ¹				
		10°F TD/25°F SST	6°C TD/-4°C SST	10°F TD/25°F SST	6°C TD/-4°C SST	No. of Fans	CFM	m ³ H
		BTUH	Watts	BTUH	Watts			
HEL0045*S6A^A	RLC040	4,600	1,300	4,600	1,300	1	653	1,109
HEL0055*S6A^A	RLC052	6,100	1,800	6,100	1,800	1	610	1,036
HEL0060*S6A^A	RLC065 RLC070	7,800	2,300	7,800	2,300	1	610	1,036
HEL0095*S6A^A	RLC070 RLC090	10,000	2,900	10,000	2,900	2	1,305	2,217
HEL0105*S6A^A	RLC090 RLC104	12,500	3,600	12,500	3,600	2	1,305	2,217
HEL0115*S6A^A	RLC120	14,500	4,180	14,500	4,180	2	1,220	2,073
HEL0125*S6A^A	RLC130	15,500	4,500	15,500	4,500	2	1,220	2,073
HEL0155*S6A^A	RLC140	16,800	4,900	16,800	4,900	3	1,958	3,327
HEL0190*S6A^A	RLC156 RLC180	21,200	6,200	21,200	6,200	3	1,830	3,109
HEL0250*S6A^A	RLC208	24,600	7,200	24,600	7,200	4	2,440	4,146
HEL0295*S6A^A	RLC260	30,700	9,000	30,700	9,000	5	3,050	5,182
HEL0350*S6A^A	RLC312	36,800	10,800	36,800	10,800	6	3,660	6,218
HEL0380*S6A^A	RLC370	44,400	13,000	44,400	13,000	6	3,660	6,218

Notes:
¹ = Capacities shown are Application Capacities reflecting nominal operation at 10°F TD. For models within the scope of the DOE AWEF (Annual Walk-in Energy Factor) standard, the Net Capacity is determined by the AHRI 1250 test method. DOE will publish this compliance data at www.regulations.doe.gov
 * = Electrical Code Designator (see Nomenclature details)
 ^ = Motor Code Designator (see Nomenclature details)
 Net Capacity is available upon request

PERFORMANCE DATA

Application Capacity: Air Defrost- 60 Hz

Please consult AWEF table on page 43 to confirm model meets DOE minimum AWEF

New Model	Legacy Model	CO ₂ DX		Fan Data		
		Application Capacity ¹				
		10°F TD/25°F SST	6°C TD/-4°C SST	No. of Fans	CFM	m ³ H
		BTUH	Watts			
HEL0045*C6A^A	N/A	4,600	1,348	1	653	1,109
HEL0055*C6A^A	N/A	6,100	1,788	1	610	1,036
HEL0060*C6A^A	N/A	7,800	2,286	1	610	1,036
HEL0095*C6A^A	N/A	10,000	2,931	2	1,305	2,217
HEL0105*C6A^A	N/A	12,500	3,663	2	1,305	2,217
HEL0115*C6A^A	N/A	14,500	4,250	2	1,220	2,073
HEL0125*C6A^A	N/A	15,500	4,543	2	1,220	2,073
HEL0155*C6A^A	N/A	16,800	4,924	3	1,958	3,327
HEL0190*C6A^A	N/A	21,200	6,213	3	1,830	3,109
HEL0250*C6A^A	N/A	24,600	7,210	4	2,440	4,146
HEL0295*C6A^A	N/A	30,700	8,997	5	3,050	5,182
HEL0350*C6A^A	N/A	36,800	10,785	6	3,660	6,218
HEL0380*C6A^A	N/A	44,400	13,012	6	3,660	6,218

Notes:

¹ = Capacities shown are Application Capacities reflecting nominal operation at 10°F TD. For models within the scope of the DOE AWEF (Annual Walk-in Energy Factor) standard, the Net Capacity is determined by the AHRI 1250 test method. DOE will publish this compliance data at www.regulations.doe.gov

* = Electrical Code Designator (see Nomenclature details)

^ = Motor Code Designator (see Nomenclature details)

Net Capacity is available upon request

PERFORMANCE DATA

Application Capacity: Air Defrost- 50 Hz (For PSC Motors)[†]

Please consult AWEF table on page 43 to confirm model meets DOE minimum AWEF

New Model	Legacy Model	R-404A/R-507A		R-448A/R-449A		Fan Data		
		Application Capacity ¹		Application Capacity ¹				
		10°F TD/25°F SST	6°C TD/-4°C SST	10°F TD/25°F SST	6°C TD/-4°C SST	No. of Fans	CFM	m ³ H
		BTUH	Watts	BTUH	Watts			
HEL0045*S6A^A	RLC040	3,800	1,140	4,370	1,235	1	588	999
HEL0055*S6A^A	RLC052	4,940	1,425	5,795	1,710	1	549	933
HEL0060*S6A^A	RLC065 RLC070	6,175	1,805	7,410	2,185	1	549	933
HEL0095*S6A^A	RLC070 RLC090	7,600	2,185	9,500	2,755	2	1,175	1,995
HEL0105*S6A^A	RLC090 RLC104	8,740	2,518	11,875	3,420	2	1,175	1,995
HEL0115*S6A^A	RLC120	11,115	3,202	13,775	3,971	2	1,098	1,866
HEL0125*S6A^A	RLC130	12,350	3,610	14,725	4,275	2	1,098	1,866
HEL0155*S6A^A	RLC140	13,300	3,895	15,960	4,655	3	1,762	2,994
HEL0190*S6A^A	RLC156 RLC180	17,100	5,035	20,140	5,890	3	1,647	2,798
HEL0250*S6A^A	RLC208	19,760	5,795	23,370	6,840	4	2,196	3,731
HEL0295*S6A^A	RLC260	24,700	7,220	29,165	8,550	5	2,745	4,664
HEL0350*S6A^A	RLC312	29,640	8,645	34,960	10,260	6	3,294	5,597
HEL0380*S6A^A	RLC370	35,150	10,260	42,180	12,350	6	3,294	5,597

New Model	Legacy Model	R-407A/R-407F		R-407C		Fan Data		
		Application Capacity ¹		Application Capacity ¹				
		10°F TD/25°F SST	6°C TD/-4°C SST	10°F TD/25°F SST	6°C TD/-4°C SST	No. of Fans	CFM	m ³ H
		BTUH	Watts	BTUH	Watts			
HEL0045*S6A^A	RLC040	4,370	1,235	4,370	1,235	1	588	999
HEL0055*S6A^A	RLC052	5,795	1,710	5,795	1,710	1	549	933
HEL0060*S6A^A	RLC065 RLC070	7,410	2,185	7,410	2,185	1	549	933
HEL0095*S6A^A	RLC070 RLC090	9,500	2,755	9,500	2,755	2	1,175	1,995
HEL0105*S6A^A	RLC090 RLC104	11,875	3,420	11,875	3,420	2	1,175	1,995
HEL0115*S6A^A	RLC120	13,775	3,971	13,775	3,971	2	1,098	1,866
HEL0125*S6A^A	RLC130	14,725	4,275	14,725	4,275	2	1,098	1,866
HEL0155*S6A^A	RLC140	15,960	4,655	15,960	4,655	3	1,762	2,994
HEL0190*S6A^A	RLC156 RLC180	20,140	5,890	20,140	5,890	3	1,647	2,798
HEL0250*S6A^A	RLC208	23,370	6,840	23,370	6,840	4	2,196	3,731
HEL0295*S6A^A	RLC260	29,165	8,550	29,165	8,550	5	2,745	4,664
HEL0350*S6A^A	RLC312	34,960	10,260	34,960	10,260	6	3,294	5,597
HEL0380*S6A^A	RLC370	42,180	12,350	42,180	12,350	6	3,294	5,597

Notes:

¹ = Capacities shown are Application Capacities reflecting nominal operation at 10°F TD. For models within the scope of the DOE AWEF (Annual Walk-in Energy Factor) standard, the Net Capacity is determined by the AHRI 1250 test method. DOE will publish this compliance data at www.regulations.doe.gov

* = Electrical Code Designator (see Nomenclature details)

^ = Motor Code Designator (see Nomenclature details)

Net Capacity is available upon request

[†] = For 1-speed and 2-speed EC motors, use 60 Hz capacity and airflow values. (units with EC motors operating at 50 Hz will not see a reduction in performance due to the electronic control of the motor)

PERFORMANCE DATA

Application Capacity: Air Defrost- 50 Hz (For PSC Motors) †

Please consult AWEF table on page 43 to confirm model meets DOE minimum AWEF

New Model	Legacy Model	CO ₂ DX		Fan Data		
		Application Capacity ¹				
		10°F TD/25°F SST	6°C TD/-4°C SST	No. of Fans	CFM	m ³ H
		BTUH	Watts			
HEL0045*C6A^A	N/A	4,370	1,281	1	588	999
HEL0055*C6A^A	N/A	5,795	1,698	1	549	933
HEL0060*C6A^A	N/A	7,410	2,172	1	549	933
HEL0095*C6A^A	N/A	9,500	2,784	2	1,175	1,996
HEL0105*C6A^A	N/A	11,875	3,480	2	1,175	1,996
HEL0115*C6A^A	N/A	13,775	4,037	2	1,098	1,866
HEL0125*C6A^A	N/A	14,725	4,315	2	1,098	1,866
HEL0155*C6A^A	N/A	15,960	4,677	3	1,762	2,994
HEL0190*C6A^A	N/A	20,140	5,902	3	1,647	2,798
HEL0250*C6A^A	N/A	23,370	6,849	4	2,196	3,731
HEL0295*C6A^A	N/A	29,165	8,547	5	2,745	4,664
HEL0350*C6A^A	N/A	34,960	10,246	6	3,294	5,597
HEL0380*C6A^A	N/A	42,180	12,362	6	3,294	5,597

Notes:

¹ = Capacities shown are Application Capacities reflecting nominal operation at 10°F TD. For models within the scope of the DOE AWEF (Annual Walk-in Energy Factor) standard, the Net Capacity is determined by the AHRI 1250 test method. DOE will publish this compliance data at www.regulations.doe.gov

* = Electrical Code Designator (see Nomenclature details)

^ = Motor Code Designator (see Nomenclature details)

Net Capacity is available upon request

† = For 1-speed and 2-speed EC motors, use 60 Hz capacity and airflow values. (units with EC motors operating at 50 Hz will not see a reduction in performance due to the electronic control of the motor)

SPECIFICATIONS

Air Defrost- 60 Hz

Please consult AWEF table on page 43 to confirm model meets DOE minimum AWEF

		2-Speed EC Motor (Totally Enclosed)							
		115/1/60				208-230/1/60			
New Model	HP	Amps	Watts	MCA	MOPD	Amps	Watts	MCA	MOPD
HEL0045*±6AMA	1/20	0.9	55	1.1	20	0.5	55	0.6	15
HEL0055*±6AMA	1/20	0.9	55	1.1	20	0.5	55	0.6	15
HEL0060*±6AMA	1/20	0.9	55	1.1	20	0.5	55	0.6	15
HEL0095*±6AMA	1/20	1.8	110	2.0	20	1.0	110	1.1	15
HEL0105*±6AMA	1/20	1.8	110	2.0	20	1.0	110	1.1	15
HEL0115*±6AMA	1/20	1.8	110	2.0	20	1.0	110	1.1	15
HEL0125*±6AMA	1/20	1.8	110	2.0	20	1.0	110	1.1	15
HEL0155*±6AMA	1/20	2.7	165	2.9	20	1.5	165	1.6	15
HEL0190*±6AMA	1/20	2.7	165	2.9	20	1.5	165	1.6	15
HEL0250*±6AMA	1/20	3.6	220	3.8	20	2.0	220	2.1	15
HEL0295*±6AMA	1/20	4.5	275	4.7	20	2.5	275	2.6	15
HEL0350*±6AMA	1/20	5.4	330	5.6	20	3.0	330	3.1	15
HEL0380*±6AMA	1/20	5.4	330	5.6	20	3.0	330	3.1	15

		1-Speed EC Motor (Totally Enclosed)							
		115/1/60				208-230/1/60			
New Model	HP	Amps	Watts	MCA	MOPD	Amps	Watts	MCA	MOPD
HEL0045*±6AEA	1/20	0.9	55	1.1	20	0.5	59	0.6	15
HEL0055*±6AEA	1/20	0.9	55	1.1	20	0.5	59	0.6	15
HEL0060*±6AEA	1/20	0.9	55	1.1	20	0.5	59	0.6	15
HEL0095*±6AEA	1/20	1.8	110	2.0	20	1.0	118	1.1	15
HEL0105*±6AEA	1/20	1.8	110	2.0	20	1.0	118	1.1	15
HEL0115*±6AEA	1/20	1.8	110	2.0	20	1.0	118	1.1	15
HEL0125*±6AEA	1/20	1.8	110	2.0	20	1.0	118	1.1	15
HEL0155*±6AEA	1/20	2.7	165	2.9	20	1.5	177	1.6	15
HEL0190*±6AEA	1/20	2.7	165	2.9	20	1.5	177	1.6	15
HEL0250*±6AEA	1/20	3.6	220	3.8	20	2.0	236	2.1	15
HEL0295*±6AEA	1/20	4.5	275	4.7	20	2.5	295	2.6	15
HEL0350*±6AEA	1/20	5.4	330	5.6	20	3.0	354	3.1	15
HEL0380*±6AEA	1/20	5.4	330	5.6	20	3.0	354	3.1	15

Notes:

* = Electrical Code Designator (see Nomenclature details)

± = Refrigerant Designator (see Nomenclature details)

SPECIFICATIONS

Air Defrost- 60 Hz

Please consult AWEF table on page 43 to confirm model meets DOE minimum AWEF

New Model	HP	PSC Motor (Totally Enclosed)											
		115/1/60				208-230/1/60				460/1/60			
		Amps	Watts	MCA	MOPD	Amps	Watts	MCA	MOPD	Amps	Watts	MCA	MOPD
HEL0045*±6ACA	1/20	1.0	82	1.3	20	0.5	91	0.6	15	0.4	117	0.5	15
HEL0055*±6ACA	1/20	1.0	82	1.3	20	0.5	91	0.6	15	0.4	117	0.5	15
HEL0060*±6ACA	1/20	1.0	82	1.3	20	0.5	91	0.6	15	0.4	117	0.5	15
HEL0095*±6ACA	1/20	2.0	164	2.3	20	1.0	182	1.1	15	0.8	234	0.9	15
HEL0105*±6ACA	1/20	2.0	164	2.3	20	1.0	182	1.1	15	0.8	234	0.9	15
HEL0115*±6ACA	1/20	2.0	164	2.3	20	1.0	182	1.1	15	0.8	234	0.9	15
HEL0125*±6ACA	1/20	2.0	164	2.3	20	1.0	182	1.1	15	0.8	234	0.9	15
HEL0155*±6ACA	1/20	3.0	246	3.3	20	1.5	273	1.6	15	1.2	351	1.3	15
HEL0190*±6ACA	1/20	3.0	246	3.3	20	1.5	273	1.6	15	1.2	351	1.3	15
HEL0250*±6ACA	1/20	4.0	328	4.3	20	2.0	364	2.1	15	1.6	468	1.7	15
HEL0295*±6ACA	1/20	5.0	410	5.3	20	2.5	455	2.6	15	2.0	585	2.1	15
HEL0350*±6ACA	1/20	6.0	492	6.3	20	3.0	546	3.1	15	2.4	702	2.5	15
HEL0380*±6ACA	1/20	6.0	492	6.3	20	3.0	546	3.1	15	2.4	702	2.5	15

Notes:

* = Electrical Code Designator (see Nomenclature details)

± = Refrigerant Designator (see Nomenclature details)

SPECIFICATIONS

Air Defrost- 50 Hz

Please consult AWEF table on page 43 to confirm model meets DOE minimum AWEF

New Model	HP	2-Speed EC Motor (Totally Enclosed)				1-Speed EC Motor (Totally Enclosed)				PSC Motor (Totally Enclosed)			
		220/1/50				220/1/50				220/1/50			
		Amps	Watts	MCA	MOPD	Amps	Watts	MCA	MOPD	Amps	Watts	MCA	MOPD
HEL0045*±6A^A	1/20	0.5	55	0.6	15	0.5	59	0.6	15	0.5	65	0.6	15
HEL0055*±6A^A	1/20	0.5	55	0.6	15	0.5	59	0.6	15	0.5	65	0.6	15
HEL0060*±6A^A	1/20	0.5	55	0.6	15	0.5	59	0.6	15	0.5	65	0.6	15
HEL0095*±6A^A	1/20	1.0	110	1.1	15	1.0	118	1.1	15	1.0	130	1.1	15
HEL0105*±6A^A	1/20	1.0	110	1.1	15	1.0	118	1.1	15	1.0	130	1.1	15
HEL0115*±6A^A	1/20	1.0	110	1.1	15	1.0	118	1.1	15	1.0	130	1.1	15
HEL0125*±6A^A	1/20	1.0	110	1.1	15	1.0	118	1.1	15	1.0	130	1.1	15
HEL0155*±6A^A	1/20	1.5	165	1.6	15	1.5	177	1.6	15	1.5	195	1.6	15
HEL0190*±6A^A	1/20	1.5	165	1.6	15	1.5	177	1.6	15	1.5	195	1.6	15
HEL0250*±6A^A	1/20	2.0	220	2.1	15	2.0	236	2.1	15	2.0	260	2.1	15
HEL0295*±6A^A	1/20	2.5	275	2.6	15	2.5	295	2.6	15	2.5	325	2.6	15
HEL0350*±6A^A	1/20	3.0	330	3.1	15	3.0	354	3.1	15	3.0	390	3.1	15
HEL0380*±6A^A	1/20	3.0	330	3.1	15	3.0	354	3.1	15	3.0	390	3.1	15

Notes:

* = Electrical Code Designator (see Nomenclature details)

^ = Motor Code Designator (see Nomenclature details)

± = Refrigerant Designator (see Nomenclature details)

PERFORMANCE DATA

Application Capacity: Low Temperature Electric Defrost- 60 Hz

Please consult AWEF table on pages 44 & 45 to confirm model meets DOE minimum AWEF

Please refer to Table 1: Capacity Correction Factors (page 6) if using Saturated Suction Temperatures different than listed in the information below

FPI	New Model	Legacy Model	R-404A/R-507A		R-448A/R-449A		Fan Data		
			Application Capacity ¹		Application Capacity ¹				
			10°F TD/-20°F SST	6°C TD/-29°C SST	10°F TD/-20°F SST	6°C TD/-29°C SST	No. of Fans	CFM	m ³ H
			BTUH	Watts	BTUH	Watts			
6	HEL0040*S6E^A	ELC035 ELC040	3,500	1,000	3,900	1,000	1	685	1,164
6	HEL0045*S6E^A	ELC040 ELC047	4,700	1,400	5,300	1,600	1	641	1,088
6	HEL0065*S6E^A	ELC065	6,500	1,900	7,200	2,100	2	1,371	2,329
6	HEL0080*S6E^A	ELC075	7,500	2,200	8,400	2,500	2	1,371	2,329
6	HEL0100*S6E^A	ELC090	9,000	2,600	9,900	2,900	2	1,281	2,176
6	HEL0130*S6E^A	ELC120	12,000	3,500	13,500	4,000	3	2,056	3,493
6	HEL0155*S6E^A	ELC140	14,000	4,100	16,000	4,700	3	1,922	3,265
6	HEL0170*S6E^A	ELC160	16,000	4,700	17,900	5,200	4	2,741	4,658
6	HEL0205*S6E^A	ELC180	18,000	5,300	20,100	5,900	4	2,562	4,353
6	HEL0240*S6E^A	ELC200	20,000	5,900	22,800	6,600	5	3,203	5,441
6	HEL0255*S6E^A	ELC240	24,000	7,000	26,900	7,900	6	4,112	6,986
6	HEL0310*S6E^A	ELC280	28,000	8,200	31,400	9,200	6	3,843	6,529
4	HEL0045*S4E^A	EFC041	4,100	1,200	4,500	1,300	1	667	1,132
4	HEL0070*S4E^A	EFC068	6,800	2,000	7,400	2,200	2	1,425	2,422
4	HEL0090*S4E^A	EFC080	8,000	2,300	8,800	2,600	2	1,332	2,263
4	HEL0135*S4E^A	EFC102	10,200	3,000	12,800	3,700	3	1,998	3,395
4	HEL0180*S4E^A	EFC136	13,600	4,000	17,300	5,000	4	2,664	4,527
4	HEL0220*S4E^A	EFC170	17,000	5,000	19,500	5,600	5	3,331	5,659
4	HEL0275*S4E^A	EFC204 EFC235	23,500	6,900	25,900	7,600	6	3,997	6,790

Notes:
¹ = Capacities shown are Application Capacities reflecting nominal operation at 10°F TD. For models within the scope of the DOE AWEF (Annual Walk-in Energy Factor) standard, the Net Capacity is determined by the AHRI 1250 test method. DOE will publish this compliance data at www.regulations.doe.gov
 * = Electrical Code Designator (see Nomenclature details)
 ^ = Motor Code Designator (see Nomenclature details)
 Net Capacity is available upon request

PERFORMANCE DATA

Application Capacity: Low Temperature Electric Defrost- 60 Hz

Please consult AWEF table on pages 44 & 45 to confirm model meets DOE minimum AWEF

Please refer to Table 1: Capacity Correction Factors (page 6) if using Saturated Suction Temperatures different than listed in the information below

FPI	New Model	Legacy Model	R-407A/R-407F		R-407C		Fan Data		
			Application Capacity ¹		Application Capacity ¹				
			10°F TD/-20°F SST	6°C TD/-29°C SST	10°F TD/-20°F SST	6°C TD/-29°C SST	No. of Fans	CFM	m ³ H
			BTUH	Watts	BTUH	Watts			
6	HEL0040*S6E^A	ELC035 ELC040	3,900	1,000	-	-	1	685	1,164
6	HEL0045*S6E^A	ELC040 ELC047	5,300	1,600	-	-	1	641	1,088
6	HEL0065*S6E^A	ELC065	7,200	2,100	-	-	2	1,371	2,329
6	HEL0080*S6E^A	ELC075	8,400	2,500	-	-	2	1,371	2,329
6	HEL0100*S6E^A	ELC090	9,900	2,900	-	-	2	1,281	2,176
6	HEL0130*S6E^A	ELC120	13,500	4,000	-	-	3	2,056	3,493
6	HEL0155*S6E^A	ELC140	16,000	4,700	-	-	3	1,922	3,265
6	HEL0170*S6E^A	ELC160	17,900	5,200	-	-	4	2,741	4,658
6	HEL0205*S6E^A	ELC180	20,100	5,900	-	-	4	2,562	4,353
6	HEL0240*S6E^A	ELC200	22,400	6,500	-	-	5	3,203	5,441
6	HEL0255*S6E^A	ELC240	26,900	7,900	-	-	6	4,112	6,986
6	HEL0310*S6E^A	ELC280	31,400	9,200	-	-	6	3,843	6,529
4	HEL0045*S4E^A	EFC041	4,500	1,300	-	-	1	667	1,132
4	HEL0070*S4E^A	EFC068	7,400	2,200	-	-	2	1,425	2,422
4	HEL0090*S4E^A	EFC080	8,800	2,600	-	-	2	1,332	2,263
4	HEL0135*S4E^A	EFC102	12,100	3,500	-	-	3	1,998	3,395
4	HEL0180*S4E^A	EFC136	16,300	4,700	-	-	4	2,664	4,527
4	HEL0220*S4E^A	EFC170	19,600	5,600	-	-	5	3,331	5,659
4	HEL0275*S4E^A	EFC204 EFC235	25,900	7,600	-	-	6	3,997	6,790

Notes:

¹ = Capacities shown are Application Capacities reflecting nominal operation at 10°F TD. For models within the scope of the DOE AWEF (Annual Walk-in Energy Factor) standard, the Net Capacity is determined by the AHRI 1250 test method. DOE will publish this compliance data at www.regulations.doe.gov

* = Electrical Code Designator (see Nomenclature details)

^ = Motor Code Designator (see Nomenclature details)

Net Capacity is available upon request

PERFORMANCE DATA

Application Capacity: Low Temperature Electric Defrost- 60 Hz

Please consult AWEF table on pages 44 & 45 to confirm model meets DOE minimum AWEF

Please refer to Table 1: Capacity Correction Factors (page 6) if using Saturated Suction Temperatures different than listed in the information below

FPI	New Model	Legacy Model	CO ₂ DX		Fan Data		
			Application Capacity ¹		No. of Fans	CFM	m ³ H
			10°F TD/-20°F SST	6°C TD/-29°C SST			
			BTUH	Watts			
6	HEL0040*C6E^A	N/A	3,900	1,143	1	685	1,164
6	HEL0045*C6E^A	N/A	5,300	1,553	1	641	1,088
6	HEL0065*C6E^A	N/A	7,200	2,110	2	1,371	2,329
6	HEL0080*C6E^A	N/A	8,400	2,462	2	1,371	2,329
6	HEL0100*C6E^A	N/A	9,900	2,901	2	1,281	2,176
6	HEL0130*C6E^A	N/A	13,500	3,956	3	2,056	3,493
6	HEL0155*C6E^A	N/A	16,000	4,689	3	1,922	3,265
6	HEL0170*C6E^A	N/A	17,900	5,246	4	2,741	4,657
6	HEL0205*C6E^A	N/A	20,100	5,891	4	2,562	4,353
6	HEL0240*C6E^A	N/A	22,400	6,565	5	3,203	5,441
6	HEL0255*C6E^A	N/A	26,900	7,884	6	4,112	6,986
6	HEL0310*C6E^A	N/A	31,400	9,202	6	3,843	6,529
4	HEL0045*C4E^A	N/A	4,500	1,319	1	667	1,132
4	HEL0070*C4E^A	N/A	7,400	2,169	2	1,425	2,422
4	HEL0090*C4E^A	N/A	8,800	2,579	2	1,332	2,263
4	HEL0135*C4E^A	N/A	12,100	3,546	3	1,998	3,395
4	HEL0180*C4E^A	N/A	16,300	4,777	4	2,664	4,527
4	HEL0220*C4E^A	N/A	19,600	5,744	5	3,331	5,659
4	HEL0275*C4E^A	N/A	25,900	7,591	6	3,997	6,790

Notes:
¹ = Capacities shown are Application Capacities reflecting nominal operation at 10°F TD. For models within the scope of the DOE AWEF (Annual Walk-in Energy Factor) standard, the Net Capacity is determined by the AHRI 1250 test method. DOE will publish this compliance data at www.regulations.doe.gov
 * = Electrical Code Designator (see Nomenclature details)
 ^ = Motor Code Designator (see Nomenclature details)
 Net Capacity is available upon request

PERFORMANCE DATA

Application Capacity: Electric Defrost- 50 Hz (For PSC Motors)[†]

Please consult AWEF table on pages 44 & 45 to confirm model meets DOE minimum AWEF

Please refer to Table 1: Capacity Correction Factors (page 6) if using Saturated Suction Temperatures different than listed in the information below

FPI	New Model	Legacy Model	R-404A/R-507A		R-448A/R-449A		Fan Data		
			Application Capacity ¹		Application Capacity ¹				
			10°F TD/-20°F SST	6°C TD/-29°C SST	10°F TD/-20°F SST	6°C TD/-29°C SST	No. of Fans	CFM	m ³ H
			BTUH	Watts	BTUH	Watts			
6	HEL0040*S6E^A	ELC035 ELC040	3,325	950	3,705	950	1	617	1,048
6	HEL0045*S6E^A	ELC040 ELC047	4,465	1,330	5,035	1,520	1	576	979
6	HEL0065*S6E^A	ELC065	6,175	1,805	6,840	1,995	2	1,234	2,096
6	HEL0080*S6E^A	ELC075	7,125	2,090	7,980	2,375	2	1,234	2,096
6	HEL0100*S6E^A	ELC090	8,550	2,470	9,405	2,755	2	1,153	1,959
6	HEL0130*S6E^A	ELC120	11,400	3,325	12,825	3,800	3	1,850	3,144
6	HEL0155*S6E^A	ELC140	13,300	3,895	15,200	4,465	3	1,729	2,938
6	HEL0170*S6E^A	ELC160	15,200	4,465	17,005	4,940	4	2,467	4,192
6	HEL0205*S6E^A	ELC180	17,100	5,035	19,095	5,605	4	2,306	3,918
6	HEL0240*S6E^A	ELC200	19,000	5,605	21,660	6,270	5	2,882	4,897
6	HEL0255*S6E^A	ELC240	22,800	6,650	25,555	7,505	6	3,701	6,288
6	HEL0310*S6E^A	ELC280	26,600	7,790	29,830	8,740	6	2,459	5,876
4	HEL0045*S4E^A	EFC041	3,895	1,140	4,275	1,235	1	600	1,019
4	HEL0070*S4E^A	EFC068	6,460	1,900	7,030	2,090	2	1,283	2,180
4	HEL0090*S4E^A	EFC080	7,600	2,185	8,360	2,470	2	1,199	2,037
4	HEL0135*S4E^A	EFC102	9,690	2,850	12,160	3,515	3	1,799	3,056
4	HEL0180*S4E^A	EFC136	12,920	3,800	16,435	4,750	4	2,398	4,074
4	HEL0220*S4E^A	EFC170	16,150	4,750	18,525	5,320	5	2,998	5,093
4	HEL0275*S4E^A	EFC204 EFC235	22,325	6,555	24,605	7,220	6	3,597	6,111

Notes:

¹ = Capacities shown are Application Capacities reflecting nominal operation at 10°F TD. For models within the scope of the DOE AWEF (Annual Walk-in Energy Factor) standard, the Net Capacity is determined by the AHRI 1250 test method. DOE will publish this compliance data at www.regulations.doe.gov

* = Electrical Code Designator (see Nomenclature details)

^ = Motor Code Designator (see Nomenclature details)

Net Capacity is available upon request

[†] = For 1-speed and 2-speed EC motors, use 60 Hz capacity and airflow values. (units with EC motors operating at 50 Hz will not see a reduction in performance due to the electronic control of the motor)

PERFORMANCE DATA

Application Capacity: Electric Defrost- 50 Hz (For PSC Motors) †

Please consult AWEF table on pages 44 & 45 to confirm model meets DOE minimum AWEF

Please refer to Table 1: Capacity Correction Factors (page 6) if using Saturated Suction Temperatures different than listed in the information below

FPI	New Model	Legacy Model	R-407A/R-407F		R-407C		Fan Data		
			Application Capacity ¹		Application Capacity ¹				
			10°F TD/-20°F SST	6°C TD/-29°C SST	10°F TD/-20°F SST	6°C TD/-29°C SST	No. of Fans	CFM	m ³ H
			BTUH	Watts	BTUH	Watts			
6	HEL0040*S6E^A	ELC035 ELC040	3,705	950	-	-	1	617	1,048
6	HEL0045*S6E^A	ELC040 ELC047	5,035	1,520	-	-	1	576	979
6	HEL0065*S6E^A	ELC065	6,840	1,995	-	-	2	1,234	2,096
6	HEL0080*S6E^A	ELC075	7,980	2,375	-	-	2	1,234	2,096
6	HEL0100*S6E^A	ELC090	9,405	2,755	-	-	2	1,153	1,959
6	HEL0130*S6E^A	ELC120	12,825	3,800	-	-	3	1,850	3,144
6	HEL0155*S6E^A	ELC140	15,200	4,465	-	-	3	1,729	2,938
6	HEL0170*S6E^A	ELC160	17,005	4,940	-	-	4	2,467	4,192
6	HEL0205*S6E^A	ELC180	19,095	5,605	-	-	4	2,306	3,918
6	HEL0240*S6E^A	ELC200	21,280	6,175	-	-	5	2,882	4,897
6	HEL0255*S6E^A	ELC240	25,555	7,505	-	-	6	3,701	6,288
6	HEL0310*S6E^A	ELC280	29,830	8,740	-	-	6	2,459	5,876
4	HEL0045*S4E^A	EFC041	4,275	1,235	-	-	1	600	1,019
4	HEL0070*S4E^A	EFC068	7,030	2,090	-	-	2	1,283	2,180
4	HEL0090*S4E^A	EFC080	8,360	2,470	-	-	2	1,199	2,037
4	HEL0135*S4E^A	EFC102	11,495	3,325	-	-	3	1,799	3,056
4	HEL0180*S4E^A	EFC136	15,485	4,465	-	-	4	2,398	4,074
4	HEL0220*S4E^A	EFC170	18,620	5,320	-	-	5	2,998	5,093
4	HEL0275*S4E^A	EFC204 EFC235	24,605	7,220	-	-	6	3,597	6,111

Notes:

¹ = Capacities shown are Application Capacities reflecting nominal operation at 10°F TD. For models within the scope of the DOE AWEF (Annual Walk-in Energy Factor) standard, the Net Capacity is determined by the AHRI 1250 test method. DOE will publish this compliance data at www.regulations.doe.gov

* = Electrical Code Designator (see Nomenclature details)

^ = Motor Code Designator (see Nomenclature details)

Net Capacity is available upon request

† = For 1-speed and 2-speed EC motors, use 60 Hz capacity and airflow values. (units with EC motors operating at 50 Hz will not see a reduction in performance due to the electronic control of the motor)

PERFORMANCE DATA

Application Capacity: Low Temperature Electric Defrost- 50 Hz (For PSC Motors) †

Please consult AWEF table on pages 44 & 45 to confirm model meets DOE minimum AWEF

Please refer to Table 1: Capacity Correction Factors (page 6) if using Saturated Suction Temperatures different than listed in the information below

FPI	New Model	Legacy Model	CO ₂ DX		Fan Data		
			Application Capacity ¹		No. of Fans	CFM	m ³ H
			10°F TD/-20°F SST	6°C TD/-29°C SST			
			BTUH	Watts			
6	HEL0040*C6E^A	N/A	3,705	1,086	1	617	1,048
6	HEL0045*C6E^A	N/A	5,035	1,476	1	576	979
6	HEL0065*C6E^A	N/A	6,840	2,005	2	1,234	2,096
6	HEL0080*C6E^A	N/A	7,980	2,339	2	1,234	2,096
6	HEL0100*C6E^A	N/A	9,405	2,756	2	1,153	1,959
6	HEL0130*C6E^A	N/A	12,825	3,759	3	1,850	3,144
6	HEL0155*C6E^A	N/A	15,200	4,455	3	1,729	2,938
6	HEL0170*C6E^A	N/A	17,005	4,984	4	2,467	4,192
6	HEL0205*C6E^A	N/A	19,095	5,596	4	2,306	3,918
6	HEL0240*C6E^A	N/A	21,280	6,237	5	2,882	4,897
6	HEL0255*C6E^A	N/A	25,555	7,489	6	3,701	6,288
6	HEL0310*C6E^A	N/A	29,830	8,742	6	2,459	5,876
4	HEL0045*C4E^A	N/A	4,275	1,253	1	600	1,019
4	HEL0070*C4E^A	N/A	7,030	2,060	2	1,283	2,180
4	HEL0090*C4E^A	N/A	8,360	2,450	2	1,199	2,037
4	HEL0135*C4E^A	N/A	11,495	3,369	3	1,799	3,056
4	HEL0180*C4E^A	N/A	15,485	4,538	4	2,398	4,074
4	HEL0220*C4E^A	N/A	18,620	5,457	5	2,998	5,093
4	HEL0275*C4E^A	N/A	24,605	7,211	6	3,597	6,111

Notes:

¹ = Capacities shown are Application Capacities reflecting nominal operation at 10°F TD. For models within the scope of the DOE AWEF (Annual Walk-in Energy Factor) standard, the Net Capacity is determined by the AHRI 1250 test method. DOE will publish this compliance data at www.regulations.doe.gov

* = Electrical Code Designator (see Nomenclature details)

^ = Motor Code Designator (see Nomenclature details)

Net Capacity is available upon request

† = For 1-speed and 2-speed EC motors, use 60 Hz capacity and airflow values. (units with EC motors operating at 50 Hz will not see a reduction in performance due to the electronic control of the motor)

PERFORMANCE DATA

Application Capacity: Medium Temperature Electric Defrost- 60 Hz

Please consult AWEF table on pages 44 & 45 to confirm model meets DOE minimum AWEF

Please refer to Table 1: Capacity Correction Factors (page 6) if using Saturated Suction Temperatures different than listed in the information below

FPI	New Model	Legacy Model	R-404A/R-507A		R-448A/R-449A		Fan Data		
			Application Capacity ¹		Application Capacity ¹				
			10°F TD/25°F SST	6°C TD/-4°F SST	10°F TD/25°F SST	6°C TD/-4°F SST	No. of Fans	CFM	m ³ H
			BTUH	Watts	BTUH	Watts			
6	HEL0040*S6E^A	ELC035 ELC040	4,000	1,200	4,500	1,300	1	685	1,164
6	HEL0045*S6E^A	ELC040 ELC047	5,400	1,550	6,100	1,750	1	641	1,088
6	HEL0065*S6E^A	ELC065	7,450	2,150	8,300	2,400	2	1,371	2,329
6	HEL0080*S6E^A	ELC075	8,650	2,500	9,650	2,800	2	1,371	2,329
6	HEL0100*S6E^A	ELC090	10,350	3,000	11,400	3,300	2	1,281	2,176
6	HEL0130*S6E^A	ELC120	13,800	4,000	15,500	4,500	3	2,056	3,493
6	HEL0155*S6E^A	ELC140	16,100	4,650	18,400	5,300	3	1,922	3,265
6	HEL0170*S6E^A	ELC160	18,400	5,300	20,600	5,950	4	2,741	4,658
6	HEL0205*S6E^A	ELC180	20,700	6,000	23,100	6,650	4	2,562	4,353
6	HEL0240*S6E^A	ELC200	23,000	6,650	25,750	7,450	5	3,203	5,441
6	HEL0255*S6E^A	ELC240	27,600	7,950	30,950	8,950	6	4,112	6,986
6	HEL0310*S6E^A	ELC280	32,200	9,300	36,100	10,400	6	3,843	6,529
4	HEL0045*S4E^A	EFC041	4,700	1,400	5,200	1,500	1	667	1,132
4	HEL0070*S4E^A	EFC068	7,800	2,250	8,500	2,450	2	1,425	2,422
4	HEL0090*S4E^A	EFC080	9,200	2,650	10,100	2,900	2	1,332	2,263
4	HEL0135*S4E^A	EFC102	11,750	3,400	13,050	3,800	3	1,998	3,395
4	HEL0180*S4E^A	EFC136	15,650	4,500	17,650	5,100	4	2,664	4,527
4	HEL0220*S4E^A	EFC170	19,550	5,650	21,850	6,300	5	3,331	5,659
4	HEL0275*S4E^A	EFC204 EFC235	27,000	7,800	29,800	8,600	6	3,997	6,790

Notes:

¹ = Capacities shown are Application Capacities reflecting nominal operation at 10°F TD. For models within the scope of the DOE AWEF (Annual Walk-in Energy Factor) standard, the Net Capacity is determined by the AHRI 1250 test method. DOE will publish this compliance data at www.regulations.doe.gov

* = Electrical Code Designator (see Nomenclature details)

^ = Motor Code Designator (see Nomenclature details)

Net Capacity is available upon request

PERFORMANCE DATA

Application Capacity: Medium Temperature Electric Defrost- 60 Hz

Please consult AWEF table on pages 44 & 45 to confirm model meets DOE minimum AWEF

Please refer to Table 1: Capacity Correction Factors (page 6) if using Saturated Suction Temperatures different than listed in the information below

FPI	New Model	Legacy Model	R-407A/R-407F		R-407C		Fan Data		
			Application Capacity ¹		Application Capacity ¹				
			10°F TD/25°F SST	6°C TD/-4°F SST	10°F TD/25°F SST	6°C TD/-4°F SST	No. of Fans	CFM	m ³ H
			BTUH	Watts	BTUH	Watts			
6	HEL0040*S6E^A	ELC035 ELC040	4,500	1,300	-	-	1	685	1,164
6	HEL0045*S6E^A	ELC040 ELC047	6,100	1,750	-	-	1	641	1,088
6	HEL0065*S6E^A	ELC065	8,300	2,400	-	-	2	1,371	2,329
6	HEL0080*S6E^A	ELC075	9,650	2,800	-	-	2	1,371	2,329
6	HEL0100*S6E^A	ELC090	11,400	3,300	-	-	2	1,281	2,176
6	HEL0130*S6E^A	ELC120	15,500	4,500	-	-	3	2,056	3,493
6	HEL0155*S6E^A	ELC140	18,400	5,300	-	-	3	1,922	3,265
6	HEL0170*S6E^A	ELC160	20,600	5,950	-	-	4	2,741	4,658
6	HEL0205*S6E^A	ELC180	23,100	6,650	-	-	4	2,562	4,353
6	HEL0240*S6E^A	ELC200	25,750	7,450	-	-	5	3,203	5,441
6	HEL0255*S6E^A	ELC240	30,950	8,950	-	-	6	4,112	6,986
6	HEL0310*S6E^A	ELC280	36,100	10,400	-	-	6	3,843	6,529
4	HEL0045*S4E^A	EFC041	5,200	1,500	-	-	1	667	1,132
4	HEL0070*S4E^A	EFC068	8,500	2,450	-	-	2	1,425	2,422
4	HEL0090*S4E^A	EFC080	10,100	2,900	-	-	2	1,332	2,263
4	HEL0135*S4E^A	EFC102	13,050	3,800	-	-	3	1,998	3,395
4	HEL0180*S4E^A	EFC136	17,650	5,100	-	-	4	2,664	4,527
4	HEL0220*S4E^A	EFC170	21,850	6,300	-	-	5	3,331	5,659
4	HEL0275*S4E^A	EFC204 EFC235	29,800	8,600	-	-	6	3,997	6,790

Notes:

¹ = Capacities shown are Application Capacities reflecting nominal operation at 10°F TD. For models within the scope of the DOE AWEF (Annual Walk-in Energy Factor) standard, the Net Capacity is determined by the AHRI 1250 test method. DOE will publish this compliance data at www.regulations.doe.gov

* = Electrical Code Designator (see Nomenclature details)

^ = Motor Code Designator (see Nomenclature details)

Net Capacity is available upon request

PERFORMANCE DATA

Application Capacity: Medium Temperature Electric Defrost- 60 Hz

Please consult AWEF table on pages 44 & 45 to confirm model meets DOE minimum AWEF

Please refer to Table 1: Capacity Correction Factors (page 6) if using Saturated Suction Temperatures different than listed in the information below

FPI	New Model	Legacy Model	CO ₂ DX		Fan Data		
			Application Capacity ¹		No. of Fans	CFM	m ³ H
			10°F TD/-20°F SST	6°C TD/-29°C SST			
			BTUH	Watts			
6	HEL0040*C6E^A	N/A	4,500	1,319	1	685	1,164
6	HEL0045*C6E^A	N/A	6,100	1,788	1	641	1,089
6	HEL0065*C6E^A	N/A	8,300	2,432	2	1,371	2,329
6	HEL0080*C6E^A	N/A	9,650	2,828	2	1,371	2,329
6	HEL0100*C6E^A	N/A	11,400	3,341	2	1,281	2,176
6	HEL0130*C6E^A	N/A	15,500	4,543	3	2,056	3,493
6	HEL0155*C6E^A	N/A	18,400	5,393	3	1,922	3,265
6	HEL0170*C6E^A	N/A	20,600	6,037	4	2,741	4,657
6	HEL0205*C6E^A	N/A	23,100	6,770	4	2,562	4,353
6	HEL0240*C6E^A	N/A	25,750	7,547	5	3,203	5,442
6	HEL0255*C6E^A	N/A	30,950	9,071	6	4,112	6,986
6	HEL0310*C6E^A	N/A	36,100	10,580	6	3,843	6,529
4	HEL0045*C4E^A	N/A	5,200	1,524	1	641	1,089
4	HEL0070*C4E^A	N/A	8,500	2,491	2	1,425	2,421
4	HEL0090*C4E^A	N/A	10,100	2,960	2	1,332	2,263
4	HEL0135*C4E^A	N/A	13,050	3,825	3	1,998	3,395
4	HEL0180*C4E^A	N/A	17,650	5,173	4	2,664	4,526
4	HEL0220*C4E^A	N/A	21,850	6,404	5	3,331	5,659
4	HEL0275*C4E^A	N/A	29,800	8,734	6	3,997	6,791

Notes:
¹ = Capacities shown are Application Capacities reflecting nominal operation at 10°F TD. For models within the scope of the DOE AWEF (Annual Walk-in Energy Factor) standard, the Net Capacity is determined by the AHRI 1250 test method. DOE will publish this compliance data at www.regulations.doe.gov
 * = Electrical Code Designator (see Nomenclature details)
 ^ = Motor Code Designator (see Nomenclature details)
 Net Capacity is available upon request

SPECIFICATIONS

Electric Defrost- 60 Hz

Please consult AWEF table on pages 44 & 45 to confirm model meets DOE minimum AWEF

FPI	New Model	HP	2-Speed EC Motor (Totally Enclosed)				Defrost Heaters-230V			Defrost Heaters-460V	
			208-230/1/60				Watts	230/1/60	230/3/60	Watts	460/1/60
			Amps	Watts	MCA	MOPD					
6	HEL0040*±6EMA	1/20	0.5	55	0.6	15	1,050	4.6	2.8	900	2.0
6	HEL0045*±6EMA	1/20	0.5	55	0.6	15	1,050	4.6	2.8	900	2.0
6	HEL0065*±6EMA	1/20	1.0	110	1.1	15	2,100	9.1	5.7	1,800	3.9
6	HEL0080*±6EMA	1/20	1.0	110	1.1	15	2,100	9.1	5.7	1,800	3.9
6	HEL0100*±6EMA	1/20	1.0	110	1.1	15	2,100	9.1	5.7	1,800	3.9
6	HEL0130*±6EMA	1/20	1.5	165	1.6	15	3,150	13.7	8.5	2,700	5.9
6	HEL0155*±6EMA	1/20	1.5	165	1.6	15	3,150	13.7	8.5	2,700	5.9
6	HEL0170*±6EMA	1/20	2.0	220	2.1	15	4,200	18.3	11.4	3,600	7.8
6	HEL0205*±6EMA	1/20	2.0	220	2.1	15	4,200	18.3	11.4	3,600	7.8
6	HEL0240*±6EMA	1/20	2.5	275	2.6	15	5,250	22.8	14.2	4,500	9.8
6	HEL0255*±6EMA	1/20	3.0	330	3.1	15	6,300	27.4	17.1	5,400	11.7
6	HEL0310*±6EMA	1/20	3.0	330	3.1	15	6,300	27.4	17.1	5,400	11.7
4	HEL0045*±4EMA	1/20	0.5	55	0.6	15	1,050	4.6	2.8	900	2.0
4	HEL0070*±4EMA	1/20	1.0	110	1.1	15	2,100	9.1	5.7	1,800	3.9
4	HEL0090*±4EMA	1/20	1.0	110	1.1	15	2,100	9.1	5.7	1,800	3.9
4	HEL0135*±4EMA	1/20	1.5	165	1.6	15	3,150	13.7	8.5	2,700	5.9
4	HEL0180*±4EMA	1/20	2.0	220	2.1	15	4,200	18.3	11.4	3,600	7.8
4	HEL0220*±4EMA	1/20	2.5	275	2.6	15	5,250	22.8	14.2	4,500	9.8
4	HEL0275*±4EMA	1/20	3.0	330	3.1	15	6,300	27.4	17.1	5,400	11.7

FPI	New Model	HP	1-Speed EC Motor (Totally Enclosed)				Defrost Heaters-230V			Defrost Heaters-460V	
			208-230/1/60				Watts	230/1/60	230/3/60	Watts	460/1/60
			Amps	Watts	MCA	MOPD					
6	HEL0040*±6EEA	1/20	0.5	59	0.6	15	1,050	4.6	2.8	900	2.0
6	HEL0045*±6EEA	1/20	0.5	59	0.6	15	1,050	4.6	2.8	900	2.0
6	HEL0065*±6EEA	1/20	1.0	118	1.1	15	2,100	9.1	5.7	1,800	3.9
6	HEL0080*±6EEA	1/20	1.0	118	1.1	15	2,100	9.1	5.7	1,800	3.9
6	HEL0100*±6EEA	1/20	1.0	118	1.1	15	2,100	9.1	5.7	1,800	3.9
6	HEL0130*±6EEA	1/20	1.5	177	1.6	15	3,150	13.7	8.5	2,700	5.9
6	HEL0155*±6EEA	1/20	1.5	177	1.6	15	3,150	13.7	8.5	2,700	5.9
6	HEL0170*±6EEA	1/20	2.0	236	2.1	15	4,200	18.3	11.4	3,600	7.8
6	HEL0205*±6EEA	1/20	2.0	236	2.1	15	4,200	18.3	11.4	3,600	7.8
6	HEL0240*±6EEA	1/20	2.5	295	2.6	15	5,250	22.8	14.2	4,500	9.8
6	HEL0255*±6EEA	1/20	3.0	354	3.1	15	6,300	27.4	17.1	5,400	11.7
6	HEL0310*±6EEA	1/20	3.0	354	3.1	15	6,300	27.4	17.1	5,400	11.7
4	HEL0045*±4EEA	1/20	0.5	59	0.6	15	1,050	4.6	2.8	900	2.0
4	HEL0070*±4EEA	1/20	1.0	118	1.1	15	2,100	9.1	5.7	1,800	3.9
4	HEL0090*±4EEA	1/20	1.0	118	1.1	15	2,100	9.1	5.7	1,800	3.9
4	HEL0135*±4EEA	1/20	1.5	177	1.6	15	3,150	13.7	8.5	2,700	5.9
4	HEL0180*±4EEA	1/20	2.0	236	2.1	15	4,200	18.3	11.4	3,600	7.8
4	HEL0220*±4EEA	1/20	2.5	295	2.6	15	5,250	22.8	14.2	4,500	9.8
4	HEL0275*±4EEA	1/20	3.0	354	3.1	15	6,300	27.4	17.1	5,400	11.7

Notes:

* = Electrical Code Designator (see Nomenclature details)
 ± = Refrigerant Designator (see Nomenclature details)

SPECIFICATIONS

Electric Defrost- 60 Hz

Please consult AWEF table on pages 44 & 45 to confirm model meets DOE minimum AWEF

FPI	New Model	HP	PSC Motor (Totally Enclosed)				Defrost Heaters-230V			Defrost Heaters-460V	
			208-230/1/60				Watts	230/1/60	230/3/60	Watts	460/1/60
			Amps	Watts	MCA	MOPD		Total Amps			Total Amps
6	HEL0040*±6ECA	1/20	0.5	91	0.6	15	1,050	4.6	2.8	900	2.0
6	HEL0045*±6ECA	1/20	0.5	91	0.6	15	1,050	4.6	2.8	900	2.0
6	HEL0065*±6ECA	1/20	1.0	182	1.1	15	2,100	9.1	5.7	1,800	3.9
6	HEL0080*±6ECA	1/20	1.0	182	1.1	15	2,100	9.1	5.7	1,800	3.9
6	HEL0100*±6ECA	1/20	1.0	182	1.1	15	2,100	9.1	5.7	1,800	3.9
6	HEL0130*±6ECA	1/20	1.5	273	1.6	15	3,150	13.7	8.5	2,700	5.9
6	HEL0155*±6ECA	1/20	1.5	273	1.6	15	3,150	13.7	8.5	2,700	5.9
6	HEL0170*±6ECA	1/20	2.0	364	2.1	15	4,200	18.3	11.4	3,600	7.8
6	HEL0205*±6ECA	1/20	2.0	364	2.1	15	4,200	18.3	11.4	3,600	7.8
6	HEL0240*±6ECA	1/20	2.5	455	2.6	15	5,250	22.8	14.2	4,500	9.8
6	HEL0255*±6ECA	1/20	3.0	546	3.1	15	6,300	27.4	17.1	5,400	11.7
6	HEL0310*±6ECA	1/20	3.0	546	3.1	15	6,300	27.4	17.1	5,400	11.7
4	HEL0045*±4ECA	1/20	0.5	91	0.6	15	1,050	4.6	2.8	900	2.0
4	HEL0070*±4ECA	1/20	1.0	182	1.1	15	2,100	9.1	5.7	1,800	3.9
4	HEL0090*±4ECA	1/20	1.0	182	1.1	15	2,100	9.1	5.7	1,800	3.9
4	HEL0135*±4ECA	1/20	1.5	273	1.6	15	3,150	13.7	8.5	2,700	5.9
4	HEL0180*±4ECA	1/20	2.0	364	2.1	15	4,200	18.3	11.4	3,600	7.8
4	HEL0220*±4ECA	1/20	2.5	455	2.6	15	5,250	22.8	14.2	4,500	9.8
4	HEL0275*±4ECA	1/20	3.0	546	3.1	15	6,300	27.4	17.1	5,400	11.7

FPI	New Model	HP	PSC Motor (Totally Enclosed)				Defrost Heaters-230V			Defrost Heaters-460V	
			460/1/60				Watts	230/1/60	230/3/60	Watts	460/1/60
			Amps	Watts	MCA	MOPD		Total Amps			Total Amps
6	HEL0040*±6ECA	1/20	0.4	117	0.5	15	1,050	4.6	2.8	900	2.0
6	HEL0045*±6ECA	1/20	0.4	117	0.5	15	1,050	4.6	2.8	900	2.0
6	HEL0065*±6ECA	1/20	0.8	234	0.9	15	2,100	9.1	5.7	1,800	3.9
6	HEL0080*±6ECA	1/20	0.8	234	0.9	15	2,100	9.1	5.7	1,800	3.9
6	HEL0100*±6ECA	1/20	0.8	234	0.9	15	2,100	9.1	5.7	1,800	3.9
6	HEL0130*±6ECA	1/20	1.2	351	1.3	15	3,150	13.7	8.5	2,700	5.9
6	HEL0155*±6ECA	1/20	1.2	351	1.3	15	3,150	13.7	8.5	2,700	5.9
6	HEL0170*±6ECA	1/20	1.6	468	1.7	15	4,200	18.3	11.4	3,600	7.8
6	HEL0205*±6ECA	1/20	1.6	468	1.7	15	4,200	18.3	11.4	3,600	7.8
6	HEL0240*±6ECA	1/20	2.0	585	2.1	15	5,250	22.8	14.2	4,500	9.8
6	HEL0255*±6ECA	1/20	2.4	702	2.5	15	6,300	27.4	17.1	5,400	11.7
6	HEL0310*±6ECA	1/20	2.4	702	2.5	15	6,300	27.4	17.1	5,400	11.7
4	HEL0045*±4ECA	1/20	0.4	117	0.5	15	1,050	4.6	2.8	900	2.0
4	HEL0070*±4ECA	1/20	0.8	234	0.9	15	2,100	9.1	5.7	1,800	3.9
4	HEL0090*±4ECA	1/20	0.8	234	0.9	15	2,100	9.1	5.7	1,800	3.9
4	HEL0135*±4ECA	1/20	1.2	351	1.3	15	3,150	13.7	8.5	2,700	5.9
4	HEL0180*±4ECA	1/20	1.6	468	1.7	15	4,200	18.3	11.4	3,600	7.8
4	HEL0220*±4ECA	1/20	2.0	585	2.1	15	5,250	22.8	14.2	4,500	9.8
4	HEL0275*±4ECA	1/20	2.4	702	2.5	15	6,300	27.4	17.1	5,400	11.7

Notes:

* = Electrical Code Designator (see Nomenclature details)

± = Refrigerant Designator (see Nomenclature details)

SPECIFICATIONS

Electric Defrost- 50 Hz

Please consult AWEF table on pages 44 & 45 to confirm model meets DOE minimum AWEF

FPI	New Model	HP	2-Speed EC Motor (Totally Enclosed)				Defrost Heaters	
			220/1/50				Watts	220/1/50 Total Amps
			Amps	Watts	MCA	MOPD		
6	HEL0040*±6EMA	1/20	0.5	55	0.6	15	960	4.4
6	HEL0045*±6EMA	1/20	0.5	55	0.6	15	960	4.4
6	HEL0065*±6EMA	1/20	1.0	110	1.1	15	1,920	8.7
6	HEL0080*±6EMA	1/20	1.0	110	1.1	15	1,920	8.7
6	HEL0100*±6EMA	1/20	1.0	110	1.1	15	1,920	8.7
6	HEL0130*±6EMA	1/20	1.5	165	1.6	15	2,880	13.1
6	HEL0155*±6EMA	1/20	1.5	165	1.6	15	2,880	13.1
6	HEL0170*±6EMA	1/20	2.0	220	2.1	15	3,845	17.5
6	HEL0205*±6EMA	1/20	2.0	220	2.1	15	3,845	17.5
6	HEL0240*±6EMA	1/20	2.5	275	2.6	15	4,805	21.8
6	HEL0255*±6EMA	1/20	3.0	330	3.1	15	5,765	26.2
6	HEL0310*±6EMA	1/20	3.0	330	3.1	15	5,765	26.2
4	HEL0045*±4EMA	1/20	0.5	55	0.6	15	960	4.4
4	HEL0070*±4EMA	1/20	1.0	110	1.1	15	1,920	8.7
4	HEL0090*±4EMA	1/20	1.0	110	1.1	15	1,920	8.7
4	HEL0135*±4EMA	1/20	1.5	165	1.6	15	2,880	13.1
4	HEL0180*±4EMA	1/20	2.0	220	2.1	15	3,845	17.5
4	HEL0220*±4EMA	1/20	2.5	275	2.6	15	4,805	21.8
4	HEL0275*±4EMA	1/20	3.0	330	3.1	15	5,765	26.2

FPI	New Model	HP	1-Speed EC Motor (Totally Enclosed)				Defrost Heaters	
			220/1/50				Watts	220/1/50 Total Amps
			Amps	Watts	MCA	MOPD		
6	HEL0040*±6EEA	1/20	0.5	59	0.6	15	960	4.4
6	HEL0045*±6EEA	1/20	0.5	59	0.6	15	960	4.4
6	HEL0065*±6EEA	1/20	1.0	118	1.1	15	1,920	8.7
6	HEL0080*±6EEA	1/20	1.0	118	1.1	15	1,920	8.7
6	HEL0100*±6EEA	1/20	1.0	118	1.1	15	1,920	8.7
6	HEL0130*±6EEA	1/20	1.5	177	1.6	15	2,880	13.1
6	HEL0155*±6EEA	1/20	1.5	177	1.6	15	2,880	13.1
6	HEL0170*±6EEA	1/20	2.0	236	2.1	15	3,845	17.5
6	HEL0205*±6EEA	1/20	2.0	236	2.1	15	3,845	17.5
6	HEL0240*±6EEA	1/20	2.5	295	2.6	15	4,805	21.8
6	HEL0255*±6EEA	1/20	3.0	354	3.1	15	5,765	26.2
6	HEL0310*±6EEA	1/20	3.0	354	3.1	15	5,765	26.2
4	HEL0045*±4EEA	1/20	0.5	59	0.6	15	960	4.4
4	HEL0070*±4EEA	1/20	1.0	118	1.1	15	1,920	8.7
4	HEL0090*±4EEA	1/20	1.0	118	1.1	15	1,920	8.7
4	HEL0135*±4EEA	1/20	1.5	177	1.6	15	2,880	13.1
4	HEL0180*±4EEA	1/20	2.0	236	2.1	15	3,845	17.5
4	HEL0220*±4EEA	1/20	2.5	295	2.6	15	4,805	21.8
4	HEL0275*±4EEA	1/20	3.0	354	3.1	15	5,765	26.2

Notes:

* = Electrical Code Designator (see Nomenclature details)

± = Refrigerant Designator (see Nomenclature details)

SPECIFICATIONS

Electric Defrost- 50 Hz

Please consult AWEF table on pages 44 & 45 to confirm model meets DOE minimum AWEF

FPI	New Model	HP	PSC Motor (Totally Enclosed)				Defrost Heaters	
			220/1/50				Watts	220/1/50
			Amps	Watts	MCA	MOPD		Total Amps
6	HEL0040*±6ECA	1/20	0.5	65	0.6	15	960	4.4
6	HEL0045*±6ECA	1/20	0.5	65	0.6	15	960	4.4
6	HEL0065*±6ECA	1/20	1.0	130	1.1	15	1,920	8.7
6	HEL0080*±6ECA	1/20	1.0	130	1.1	15	1,920	8.7
6	HEL0100*±6ECA	1/20	1.0	130	1.1	15	1,920	8.7
6	HEL0130*±6ECA	1/20	1.5	195	1.6	15	2,880	13.1
6	HEL0155*±6ECA	1/20	1.5	195	1.6	15	2,880	13.1
6	HEL0170*±6ECA	1/20	2.0	260	2.1	15	3,845	17.5
6	HEL0205*±6ECA	1/20	2.0	260	2.1	15	3,845	17.5
6	HEL0240*±6ECA	1/20	2.5	325	2.6	15	4,805	21.8
6	HEL0255*±6ECA	1/20	3.0	390	3.1	15	5,765	26.2
6	HEL0310*±6ECA	1/20	3.0	390	3.1	15	5,765	26.2
4	HEL0045*±4ECA	1/20	0.5	65	0.6	15	960	4.4
4	HEL0070*±4ECA	1/20	1.0	130	1.1	15	1,920	8.7
4	HEL0090*±4ECA	1/20	1.0	130	1.1	15	1,920	8.7
4	HEL0135*±4ECA	1/20	1.5	195	1.6	15	2,880	13.1
4	HEL0180*±4ECA	1/20	2.0	260	2.1	15	3,845	17.5
4	HEL0220*±4ECA	1/20	2.5	325	2.6	15	4,805	21.8
4	HEL0275*±4ECA	1/20	3.0	390	3.1	15	5,765	26.2

Notes:

* = Electrical Code Designator (see Nomenclature details)

± = Refrigerant Designator (see Nomenclature details)

PERFORMANCE DATA

Application Capacity: Low Temperature Hot Gas Defrost- 60 Hz

Please consult AWEF table on pages 46 & 47 to confirm model meets DOE minimum AWEF

Please refer to Table 1: Capacity Correction Factors (page 6) if using Saturated Suction Temperatures different than listed in the information below

FPI	New Model	Legacy Model	R-404A/R-507A		R-448A/R-449A		Fan Data		
			Application Capacity ¹		Application Capacity ¹				
			10°F TD/-20°F SST	6°C TD/-29°C SST	10°F TD/-20°F SST	6°C TD/-29°C SST	No. of Fans	CFM	m ³ H
			BTUH	Watts	BTUH	Watts			
6	HEL0040*S6H^A	GLC035 GLC040	3,500	1,000	3,900	1,000	1	685	1,164
6	HEL0045*S6H^A	GLC040 GLC047	4,700	1,400	5,300	1,600	1	641	1,088
6	HEL0065*S6H^A	GLC065	6,500	1,900	7,200	2,100	2	1,371	2,329
6	HEL0080*S6H^A	GLC075	7,500	2,200	8,400	2,500	2	1,371	2,329
6	HEL0100*S6H^A	GLC090	9,000	2,600	9,900	2,900	2	1,281	2,176
6	HEL0130*S6H^A	GLC120	12,000	3,500	13,500	4,000	3	2,056	3,493
6	HEL0155*S6H^A	GLC140	14,000	4,100	16,000	4,700	3	1,922	3,265
6	HEL0170*S6H^A	GLC160	16,000	4,700	17,900	5,200	4	2,741	4,658
6	HEL0205*S6H^A	GLC180	18,000	5,300	20,100	5,900	4	2,562	4,353
6	HEL0240*S6H^A	GLC200	20,000	5,900	22,800	6,600	5	3,203	5,441
6	HEL0255*S6H^A	GLC240	24,000	7,000	26,900	7,900	6	4,112	6,986
6	HEL0310*S6H^A	GLC280	28,000	8,200	31,400	9,200	6	3,843	6,529
4	HEL0045*S4H^A	GLC041	4,100	1,200	4,500	1,300	1	667	1,132
4	HEL0070*S4H^A	GLC068	6,800	2,000	7,400	2,200	2	1,425	2,422
4	HEL0090*S4H^A	GLC080	8,000	2,300	8,800	2,600	2	1,332	2,263
4	HEL0135*S4H^A	GLC102	10,200	3,000	12,800	3,700	3	1,998	3,395
4	HEL0180*S4H^A	GLC136	13,600	4,000	17,300	5,000	4	2,664	4,527
4	HEL0220*S4H^A	GLC170	17,000	5,000	19,500	5,600	5	3,331	5,659
4	HEL0275*S4H^A	GLC204 GLC235	23,500	6,900	25,900	7,600	6	3,997	6,790

Notes:

¹ = Capacities shown are Application Capacities reflecting nominal operation at 10°F TD. For models within the scope of the DOE AWEF (Annual Walk-in Energy Factor) standard, the Net Capacity is determined by the AHRI 1250 test method. DOE will publish this compliance data at www.regulations.doe.gov

* = Electrical Code Designator (see Nomenclature details)

^ = Motor Code Designator (see Nomenclature details)

Net Capacity is available upon request

PERFORMANCE DATA

Application Capacity: Low Temperature Hot Gas Defrost- 60 Hz

Please consult AWEF table on pages 46 & 47 to confirm model meets DOE minimum AWEF

Please refer to Table 1: Capacity Correction Factors (page 6) if using Saturated Suction Temperatures different than listed in the information below

FPI	New Model	Legacy Model	R-407A/R-407F		R-407C		Fan Data		
			Application Capacity ¹		Application Capacity ¹				
			10°F TD/-20°F SST	6°C TD/-29°C SST	10°F TD/-20°F SST	6°C TD/-29°C SST	No. of Fans	CFM	m ³ H
			BTUH	Watts	BTUH	Watts			
6	HEL0040*S6H^A	GLC035 GLC040	3,900	1,000	-	-	1	685	1,164
6	HEL0045*S6H^A	GLC040 GLC047	5,300	1,600	-	-	1	641	1,088
6	HEL0065*S6H^A	GLC065	7,200	2,100	-	-	2	1,371	2,329
6	HEL0080*S6H^A	GLC075	8,400	2,500	-	-	2	1,371	2,329
6	HEL0100*S6H^A	GLC090	9,900	2,900	-	-	2	1,281	2,176
6	HEL0130*S6H^A	GLC120	13,500	4,000	-	-	3	2,056	3,493
6	HEL0155*S6H^A	GLC140	16,000	4,700	-	-	3	1,922	3,265
6	HEL0170*S6H^A	GLC160	17,900	5,200	-	-	4	2,741	4,658
6	HEL0205*S6H^A	GLC180	20,100	5,900	-	-	4	2,562	4,353
6	HEL0240*S6H^A	GLC200	22,400	6,500	-	-	5	3,203	5,441
6	HEL0255*S6H^A	GLC240	26,900	7,900	-	-	6	4,112	6,986
6	HEL0310*S6H^A	GLC280	31,400	9,200	-	-	6	3,843	6,529
4	HEL0045*S4H^A	GLC041	4,500	1,300	-	-	1	667	1,132
4	HEL0070*S4H^A	GLC068	7,400	2,200	-	-	2	1,425	2,422
4	HEL0090*S4H^A	GLC080	8,800	2,600	-	-	2	1,332	2,263
4	HEL0135*S4H^A	GLC102	12,100	3,500	-	-	3	1,998	3,395
4	HEL0180*S4H^A	GLC136	16,300	4,700	-	-	4	2,664	4,527
4	HEL0220*S4H^A	GLC170	19,600	5,500	-	-	5	3,331	5,659
4	HEL0275*S4H^A	GLC204 GLC235	25,900	7,600	-	-	6	3,997	6,790

Notes:
¹ = Capacities shown are Application Capacities reflecting nominal operation at 10°F TD. For models within the scope of the DOE AWEF (Annual Walk-in Energy Factor) standard, the Net Capacity is determined by the AHRI 1250 test method. DOE will publish this compliance data at www.regulations.doe.gov
 * = Electrical Code Designator (see Nomenclature details)
 ^ = Motor Code Designator (see Nomenclature details)
 Net Capacity is available upon request

PERFORMANCE DATA

Application Capacity: Low Temperature Hot Gas Defrost- 50 Hz (For PSC Motors)[†]

Please consult AWEF table on pages 46 & 47 to confirm model meets DOE minimum AWEF

Please refer to Table 1: Capacity Correction Factors (page 6) if using Saturated Suction Temperatures different than listed in the information below

FPI	New Model	Legacy Model	R-404A/R-507A		R-448A/R-449A		Fan Data		
			Application Capacity ¹		Application Capacity ¹				
			10°F TD/-20°F SST	6°C TD/-29°C SST	10°F TD/-20°F SST	6°C TD/-29°C SST	No. of Fans	CFM	m ³ H
			BTUH	Watts	BTUH	Watts			
6	HEL0040*S6H^A	GLC035 GLC040	3,325	950	3,705	950	1	617	1,048
6	HEL0045*S6H^A	GLC040 GLC047	4,465	1,330	5,035	1,520	1	576	979
6	HEL0065*S6H^A	GLC065	6,175	1,805	6,840	1,995	2	1,234	2,096
6	HEL0080*S6H^A	GLC075	7,125	2,090	7,980	2,375	2	1,234	2,096
6	HEL0100*S6H^A	GLC090	8,550	2,470	9,405	2,755	2	1,153	1,959
6	HEL0130*S6H^A	GLC120	11,400	3,325	12,825	3,800	3	1,850	3,144
6	HEL0155*S6H^A	GLC140	13,300	3,895	15,200	4,465	3	1,729	2,938
6	HEL0170*S6H^A	GLC160	15,200	4,465	17,005	4,940	4	2,467	4,192
6	HEL0205*S6H^A	GLC180	17,100	5,035	19,095	5,605	4	2,306	3,918
6	HEL0240*S6H^A	GLC200	19,000	5,605	21,660	6,270	5	2,882	4,897
6	HEL0255*S6H^A	GLC240	22,800	6,650	25,555	7,505	6	3,701	6,288
6	HEL0310*S6H^A	GLC280	26,600	7,790	29,830	8,740	6	2,459	5,876
4	HEL0045*S4H^A	GLC041	3,895	1,140	4,275	1,235	1	600	1,019
4	HEL0070*S4H^A	GLC068	6,460	1,900	7,030	2,090	2	1,283	2,180
4	HEL0090*S4H^A	GLC080	7,600	2,185	8,360	2,470	2	1,199	2,037
4	HEL0135*S4H^A	GLC102	9,690	2,850	12,160	3,515	3	1,799	3,056
4	HEL0180*S4H^A	GLC136	12,920	3,800	16,435	4,750	4	2,398	4,074
4	HEL0220*S4H^A	GLC170	16,150	4,750	18,525	5,320	5	2,998	5,093
4	HEL0275*S4H^A	GLC204 GLC235	22,325	6,555	24,605	7,220	6	3,597	6,111

Notes:

¹ = Capacities shown are Application Capacities reflecting nominal operation at 10°F TD. For models within the scope of the DOE AWEF (Annual Walk-in Energy Factor) standard, the Net Capacity is determined by the AHRI 1250 test method. DOE will publish this compliance data at www.regulations.doe.gov

* = Electrical Code Designator (see Nomenclature details)

^ = Motor Code Designator (see Nomenclature details)

Net Capacity is available upon request

[†] = For 1-speed and 2-speed EC motors, use 60 Hz capacity and airflow values. (units with EC motors operating at 50 Hz will not see a reduction in performance due to the electronic control of the motor)

PERFORMANCE DATA

Application Capacity: Low Temperature Hot Gas Defrost- 50 Hz (For PSC Motors)[†]

Please consult AWEF table on pages 46 & 47 to confirm model meets DOE minimum AWEF

Please refer to Table 1: Capacity Correction Factors (page 6) if using Saturated Suction Temperatures different than listed in the information below

FPI	New Model	Legacy Model	R-407A/R-407F		R-407C		Fan Data		
			Application Capacity ¹		Application Capacity ¹				
			10°F TD/-20°F SST	6°C TD/-29°C SST	10°F TD/-20°F SST	6°C TD/-29°C SST	No. of Fans	CFM	m ³ H
			BTUH	Watts	BTUH	Watts			
6	HEL0040*S6H^A	GLC035 GLC040	3,705	950	-	-	1	617	1,048
6	HEL0045*S6H^A	GLC040 GLC047	5,035	1,520	-	-	1	576	979
6	HEL0065*S6H^A	GLC065	6,840	1,995	-	-	2	1,234	2,096
6	HEL0080*S6H^A	GLC075	7,980	2,375	-	-	2	1,234	2,096
6	HEL0100*S6H^A	GLC090	9,405	2,755	-	-	2	1,153	1,959
6	HEL0130*S6H^A	GLC120	12,825	3,800	-	-	3	1,850	3,144
6	HEL0155*S6H^A	GLC140	15,200	4,465	-	-	3	1,729	2,938
6	HEL0170*S6H^A	GLC160	17,005	4,940	-	-	4	2,467	4,192
6	HEL0205*S6H^A	GLC180	19,095	5,605	-	-	4	2,306	3,918
6	HEL0240*S6H^A	GLC200	21,280	6,175	-	-	5	2,882	4,897
6	HEL0255*S6H^A	GLC240	25,555	7,505	-	-	6	3,701	6,288
6	HEL0310*S6H^A	GLC280	29,830	8,740	-	-	6	2,459	5,876
4	HEL0045*S4H^A	GLC041	4,275	1,235	-	-	1	600	1,019
4	HEL0070*S4H^A	GLC068	7,030	2,090	-	-	2	1,283	2,180
4	HEL0090*S4H^A	GLC080	8,360	2,470	-	-	2	1,199	2,037
4	HEL0135*S4H^A	GLC102	11,495	3,325	-	-	3	1,799	3,056
4	HEL0180*S4H^A	GLC136	15,485	4,465	-	-	4	2,398	4,074
4	HEL0220*S4H^A	GLC170	18,620	5,225	-	-	5	2,998	5,093
4	HEL0275*S4H^A	GLC204 GLC235	24,605	7,220	-	-	6	3,597	6,111

Notes:

¹ = Capacities shown are Application Capacities reflecting nominal operation at 10°F TD. For models within the scope of the DOE AWEF (Annual Walk-in Energy Factor) standard, the Net Capacity is determined by the AHRI 1250 test method. DOE will publish this compliance data at www.regulations.doe.gov

* = Electrical Code Designator (see Nomenclature details)

^ = Motor Code Designator (see Nomenclature details)

Net Capacity is available upon request

[†] = For 1-speed and 2-speed EC motors, use 60 Hz capacity and airflow values. (units with EC motors operating at 50 Hz will not see a reduction in performance due to the electronic control of the motor)

PERFORMANCE DATA

Application Capacity: Medium Temperature Hot Gas Defrost- 60 Hz

Please consult AWEF table on pages 46 & 47 to confirm model meets DOE minimum AWEF

Please refer to Table 1: Capacity Correction Factors (page 6) if using Saturated Suction Temperatures different than listed in the information below

FPI	New Model	Legacy Model	R-404A/R-507A		R-448A/R-449A		Fan Data		
			Application Capacity ¹		Application Capacity ¹				
			10°F TD/25°F SST	6°C TD/-4°F SST	10°F TD/25°F SST	6°C TD/-4°F SST	No. of Fans	CFM	m ³ H
			BTUH	Watts	BTUH	Watts			
6	HEL0040*S6H^A	GLC035 GLC040	4,000	1,200	4,500	1,300	1	685	1,164
6	HEL0045*S6H^A	GLC040 GLC047	5,400	1,550	6,100	1,750	1	641	1,088
6	HEL0065*S6H^A	GLC065	7,450	2,150	8,300	2,400	2	1,371	2,329
6	HEL0080*S6H^A	GLC075	8,650	2,500	9,650	2,800	2	1,371	2,329
6	HEL0100*S6H^A	GLC090	10,350	3,000	11,400	3,300	2	1,281	2,176
6	HEL0130*S6H^A	GLC120	13,800	4,000	15,500	4,500	3	2,056	3,493
6	HEL0155*S6H^A	GLC140	16,100	4,650	18,400	5,300	3	1,922	3,265
6	HEL0170*S6H^A	GLC160	18,400	5,300	20,600	5,950	4	2,741	4,658
6	HEL0205*S6H^A	GLC180	20,700	6,000	23,100	6,650	4	2,562	4,353
6	HEL0240*S6H^A	GLC200	23,000	6,650	25,750	7,450	5	3,203	5,441
6	HEL0255*S6H^A	GLC240	27,600	7,950	30,950	8,950	6	4,112	6,986
6	HEL0310*S6H^A	GLC280	32,200	9,300	36,100	10,400	6	3,843	6,529
4	HEL0045*S4H^A	GLC041	4,700	1,400	5,200	1,500	1	667	1,132
4	HEL0070*S4H^A	GLC068	7,800	2,250	8,500	2,450	2	1,425	2,422
4	HEL0090*S4H^A	GLC080	9,200	2,650	10,100	2,900	2	1,332	2,263
4	HEL0135*S4H^A	GLC102	11,750	3,400	13,050	3,800	3	1,998	3,395
4	HEL0180*S4H^A	GLC136	15,650	4,500	17,650	5,100	4	2,664	4,527
4	HEL0220*S4H^A	GLC170	19,550	5,650	21,850	6,300	5	3,331	5,659
4	HEL0275*S4H^A	GLC204 GLC235	27,000	7,800	29,800	8,600	6	3,997	6,790

Notes:

¹ = Capacities shown are Application Capacities reflecting nominal operation at 10°F TD. For models within the scope of the DOE AWEF (Annual Walk-in Energy Factor) standard, the Net Capacity is determined by the AHRI 1250 test method. DOE will publish this compliance data at www.regulations.doe.gov

* = Electrical Code Designator (see Nomenclature details)

^ = Motor Code Designator (see Nomenclature details)

Net Capacity is available upon request

PERFORMANCE DATA

Application Capacity: Medium Temperature Hot Gas Defrost- 60 Hz

Please consult AWEF table on pages 46 & 47 to confirm model meets DOE minimum AWEF

Please refer to Table 1: Capacity Correction Factors (page 6) if using Saturated Suction Temperatures different than listed in the information below

FPI	New Model	Legacy Model	R-407A/R-407F		R-407C		Fan Data		
			Application Capacity ¹		Application Capacity ¹				
			10°F TD/25°F SST	6°C TD/-4°F SST	10°F TD/25°F SST	6°C TD/-4°F SST	No. of Fans	CFM	m ³ H
			BTUH	Watts	BTUH	Watts			
6	HEL0040*S6H^A	GLC035 GLC040	4,500	1,300	-	-	1	685	1,164
6	HEL0045*S6H^A	GLC040 GLC047	6,100	1,750	-	-	1	641	1,088
6	HEL0065*S6H^A	GLC065	8,300	2,400	-	-	2	1,371	2,329
6	HEL0080*S6H^A	GLC075	9,650	2,800	-	-	2	1,371	2,329
6	HEL0100*S6H^A	GLC090	11,400	3,300	-	-	2	1,281	2,176
6	HEL0130*S6H^A	GLC120	15,500	4,500	-	-	3	2,056	3,493
6	HEL0155*S6H^A	GLC140	18,400	5,300	-	-	3	1,922	3,265
6	HEL0170*S6H^A	GLC160	20,600	5,950	-	-	4	2,741	4,658
6	HEL0205*S6H^A	GLC180	23,100	6,650	-	-	4	2,562	4,353
6	HEL0240*S6H^A	GLC200	25,750	7,450	-	-	5	3,203	5,441
6	HEL0255*S6H^A	GLC240	30,950	8,950	-	-	6	4,112	6,986
6	HEL0310*S6H^A	GLC280	36,100	10,400	-	-	6	3,843	6,529
4	HEL0045*S4H^A	GLC041	5,200	1,500	-	-	1	667	1,132
4	HEL0070*S4H^A	GLC068	8,500	2,450	-	-	2	1,425	2,422
4	HEL0090*S4H^A	GLC080	10,100	2,900	-	-	2	1,332	2,263
4	HEL0135*S4H^A	GLC102	13,050	3,800	-	-	3	1,998	3,395
4	HEL0180*S4H^A	GLC136	17,650	5,100	-	-	4	2,664	4,527
4	HEL0220*S4H^A	GLC170	21,850	6,300	-	-	5	3,331	5,659
4	HEL0275*S4H^A	GLC204 GLC235	29,800	8,600	-	-	6	3,997	6,790

Notes:
¹ = Capacities shown are Application Capacities reflecting nominal operation at 10°F TD. For models within the scope of the DOE AWEF (Annual Walk-in Energy Factor) standard, the Net Capacity is determined by the AHRI 1250 test method. DOE will publish this compliance data at www.regulations.doe.gov
 * = Electrical Code Designator (see Nomenclature details)
 ^ = Motor Code Designator (see Nomenclature details)
 Net Capacity is available upon request

SPECIFICATIONS

Hot Gas Defrost- 60 Hz

Please consult AWEF table on pages 46 & 47 to confirm model meets DOE minimum AWEF

FPI	New Model	HP	2-Speed EC Motor (Totally Enclosed)				Drain Pan Heaters			
			115/1/60				Watts	115/1/60	230/1/60	460/1/60
			Amps	Watts	MCA	MOPD		Total Amps		
6	HEL0040*S6HMA	1/20	0.9	55	1.1	20	150	1.3	0.7	0.3
6	HEL0045*S6HMA	1/20	0.9	55	1.1	20	150	1.3	0.7	0.3
6	HEL0065*S6HMA	1/20	1.8	110	2.0	20	300	2.6	1.3	0.7
6	HEL0080*S6HMA	1/20	1.8	110	2.0	20	300	2.6	1.3	0.7
6	HEL0100*S6HMA	1/20	1.8	110	2.0	20	300	2.6	1.3	0.7
6	HEL0130*S6HMA	1/20	2.7	165	2.9	20	450	3.9	2.0	1.0
6	HEL0155*S6HMA	1/20	2.7	165	2.9	20	450	3.9	2.0	1.0
6	HEL0170*S6HMA	1/20	3.6	220	3.8	20	600	5.2	2.6	1.3
6	HEL0205*S6HMA	1/20	3.6	220	3.8	20	600	5.2	2.6	1.3
6	HEL0240*S6HMA	1/20	4.5	275	4.7	20	750	6.5	3.3	1.6
6	HEL0255*S6HMA	1/20	5.4	330	5.6	20	900	7.8	3.9	2.0
6	HEL0310*S6HMA	1/20	5.4	330	5.6	20	900	7.8	3.9	2.0
4	HEL0045*S4HMA	1/20	0.9	55	1.1	20	150	1.3	0.7	0.3
4	HEL0070*S4HMA	1/20	1.8	110	2.0	20	300	2.6	1.3	0.7
4	HEL0090*S4HMA	1/20	1.8	110	2.0	20	300	2.6	1.3	0.7
4	HEL0135*S4HMA	1/20	2.7	165	2.9	20	450	3.9	2.0	1.0
4	HEL0180*S4HMA	1/20	3.6	220	3.8	20	600	5.2	2.6	1.3
4	HEL0220*S4HMA	1/20	4.5	275	4.7	20	750	6.5	3.3	1.6
4	HEL0275*S4HMA	1/20	5.4	330	5.6	20	900	7.8	3.9	2.0

FPI	New Model	HP	2-Speed EC Motor (Totally Enclosed)				Drain Pan Heaters			
			208-230/1/60				Watts	115/1/60	230/1/60	460/1/60
			Amps	Watts	MCA	MOPD		Total Amps		
6	HEL0040*S6HMA	1/20	0.5	55	0.6	15	150	1.3	0.7	0.3
6	HEL0045*S6HMA	1/20	0.5	55	0.6	15	150	1.3	0.7	0.3
6	HEL0065*S6HMA	1/20	1.0	110	1.1	15	300	2.6	1.3	0.7
6	HEL0080*S6HMA	1/20	1.0	110	1.1	15	300	2.6	1.3	0.7
6	HEL0100*S6HMA	1/20	1.0	110	1.1	15	300	2.6	1.3	0.7
6	HEL0130*S6HMA	1/20	1.4	165	1.6	15	450	3.9	2.0	1.0
6	HEL0155*S6HMA	1/20	1.4	165	1.6	15	450	3.9	2.0	1.0
6	HEL0170*S6HMA	1/20	1.9	220	2.1	15	600	5.2	2.6	1.3
6	HEL0205*S6HMA	1/20	1.9	220	2.1	15	600	5.2	2.6	1.3
6	HEL0240*S6HMA	1/20	2.4	275	2.6	15	750	6.5	3.3	1.6
6	HEL0255*S6HMA	1/20	2.9	330	3.1	15	900	7.8	3.9	2.0
6	HEL0310*S6HMA	1/20	2.9	330	3.1	15	900	7.8	3.9	2.0
4	HEL0045*S4HMA	1/20	0.5	55	0.6	15	150	1.3	0.7	0.3
4	HEL0070*S4HMA	1/20	1.0	110	1.1	15	300	2.6	1.3	0.7
4	HEL0090*S4HMA	1/20	1.0	110	1.1	15	300	2.6	1.3	0.7
4	HEL0135*S4HMA	1/20	1.4	165	1.6	15	450	3.9	2.0	1.0
4	HEL0180*S4HMA	1/20	1.9	220	2.1	15	600	5.2	2.6	1.3
4	HEL0220*S4HMA	1/20	2.4	275	2.6	15	750	6.5	3.3	1.6
4	HEL0275*S4HMA	1/20	2.9	330	3.1	15	900	7.8	3.9	2.0

Notes:

* = Electrical Code Designator (see Nomenclature details)

SPECIFICATIONS

Hot Gas Defrost- 60 Hz

Please consult AWEF table on pages 46 & 47 to confirm model meets DOE minimum AWEF

FPI	New Model	HP	1-Speed EC Motor (Totally Enclosed)				Watts	Drain Pan Heaters		
			115/1/60					115/1/60	230/1/60	460/1/60
			Amps	Watts	MCA	MOPD				
6	HEL0040*S6HEA	1/20	0.9	55	1.1	20	150	1.3	0.7	0.3
6	HEL0045*S6HEA	1/20	0.9	55	1.1	20	150	1.3	0.7	0.3
6	HEL0065*S6HEA	1/20	1.8	110	2.0	20	300	2.6	1.3	0.7
6	HEL0080*S6HEA	1/20	1.8	110	2.0	20	300	2.6	1.3	0.7
6	HEL0100*S6HEA	1/20	1.8	110	2.0	20	300	2.6	1.3	0.7
6	HEL0130*S6HEA	1/20	2.7	165	2.9	20	450	3.9	2.0	1.0
6	HEL0155*S6HEA	1/20	2.7	165	2.9	20	450	3.9	2.0	1.0
6	HEL0170*S6HEA	1/20	3.6	220	3.8	20	600	5.2	2.6	1.3
6	HEL0205*S6HEA	1/20	3.6	220	3.8	20	600	5.2	2.6	1.3
6	HEL0240*S6HEA	1/20	4.5	270	4.7	20	750	6.5	3.3	1.6
6	HEL0255*S6HEA	1/20	5.4	330	5.6	20	900	7.8	3.9	2.0
6	HEL0310*S6HEA	1/20	5.4	330	5.6	20	900	7.8	3.9	2.0
4	HEL0045*S4HEA	1/20	0.9	55	1.1	20	150	1.3	0.7	0.3
4	HEL0070*S4HEA	1/20	1.8	110	2.0	20	300	2.6	1.3	0.7
4	HEL0090*S4HEA	1/20	1.8	110	2.0	20	300	2.6	1.3	0.7
4	HEL0135*S4HEA	1/20	2.7	165	2.9	20	450	3.9	2.0	1.0
4	HEL0180*S4HEA	1/20	3.6	220	3.8	20	600	5.2	2.6	1.3
4	HEL0220*S4HEA	1/20	4.5	275	4.7	20	750	6.5	3.3	1.6
4	HEL0275*S4HEA	1/20	5.4	330	5.6	20	900	7.8	3.9	2.0

FPI	New Model	HP	1-Speed EC Motor (Totally Enclosed)				Watts	Drain Pan Heaters		
			208-230/1/60					115/1/60	230/1/60	460/1/60
			Amps	Watts	MCA	MOPD				
6	HEL0040*S6HEA	1/20	0.5	59	0.6	15	150	1.3	0.7	0.3
6	HEL0045*S6HEA	1/20	0.5	59	0.6	15	150	1.3	0.7	0.3
6	HEL0065*S6HEA	1/20	1.0	118	1.1	15	300	2.6	1.3	0.7
6	HEL0080*S6HEA	1/20	1.0	118	1.1	15	300	2.6	1.3	0.7
6	HEL0100*S6HEA	1/20	1.0	118	1.1	15	300	2.6	1.3	0.7
6	HEL0130*S6HEA	1/20	1.5	177	1.6	15	450	3.9	2.0	1.0
6	HEL0155*S6HEA	1/20	1.5	177	1.6	15	450	3.9	2.0	1.0
6	HEL0170*S6HEA	1/20	2.0	236	2.1	15	600	5.2	2.6	1.3
6	HEL0205*S6HEA	1/20	2.0	236	2.1	15	600	5.2	2.6	1.3
6	HEL0240*S6HEA	1/20	2.5	295	2.6	15	750	6.5	3.3	1.6
6	HEL0255*S6HEA	1/20	3.0	354	3.1	15	900	7.8	3.9	2.0
6	HEL0310*S6HEA	1/20	3.0	354	3.1	15	900	7.8	3.9	2.0
4	HEL0045*S4HEA	1/20	0.5	59	0.6	15	150	1.3	0.7	0.3
4	HEL0070*S4HEA	1/20	1.0	118	1.1	15	300	2.6	1.3	0.7
4	HEL0090*S4HEA	1/20	1.0	118	1.1	15	300	2.6	1.3	0.7
4	HEL0135*S4HEA	1/20	1.5	177	1.6	15	450	3.9	2.0	1.0
4	HEL0180*S4HEA	1/20	2.0	236	2.1	15	600	5.2	2.6	1.3
4	HEL0220*S4HEA	1/20	2.5	295	2.6	15	750	6.5	3.3	1.6
4	HEL0275*S4HEA	1/20	3.0	354	3.1	15	900	7.8	3.9	2.0

Notes:

* = Electrical Code Designator (see Nomenclature details)

SPECIFICATIONS

Hot Gas Defrost- 60 Hz

Please consult AWEF table on pages 46 & 47 to confirm model meets DOE minimum AWEF

FPI	New Model	HP	PSC Motor (Totally Enclosed)				Drain Pan Heaters			
			115/1/60				Watts	115/1/60	230/1/60	460/1/60
			Amps	Watts	MCA	MOPD		Total Amps		
6	HEL0040*S6HCA	1/20	1.0	82	1.3	20	150	1.3	0.7	0.3
6	HEL0045*S6HCA	1/20	1.0	82	1.3	20	150	1.3	0.7	0.3
6	HEL0065*S6HCA	1/20	2.0	164	2.3	20	300	2.6	1.3	0.7
6	HEL0080*S6HCA	1/20	2.0	164	2.3	20	300	2.6	1.3	0.7
6	HEL0100*S6HCA	1/20	2.0	164	2.3	20	300	2.6	1.3	0.7
6	HEL0130*S6HCA	1/20	3.0	246	3.3	20	450	3.9	2.0	1.0
6	HEL0155*S6HCA	1/20	3.0	246	3.3	20	450	3.9	2.0	1.0
6	HEL0170*S6HCA	1/20	4.0	328	4.3	20	600	5.2	2.6	1.3
6	HEL0205*S6HCA	1/20	4.0	328	4.3	20	600	5.2	2.6	1.3
6	HEL0240*S6HCA	1/20	5.0	410	5.3	20	750	6.5	3.3	1.6
6	HEL0255*S6HCA	1/20	6.0	492	6.3	20	900	7.8	3.9	2.0
6	HEL0310*S6HCA	1/20	6.0	492	6.3	20	900	7.8	3.9	2.0
4	HEL0045*S4HCA	1/20	1.0	82	1.3	20	150	1.3	0.7	0.3
4	HEL0070*S4HCA	1/20	2.0	164	2.3	20	300	2.6	1.3	0.7
4	HEL0090*S4HCA	1/20	2.0	164	2.3	20	300	2.6	1.3	0.7
4	HEL0135*S4HCA	1/20	3.0	246	3.3	20	450	3.9	2.0	1.0
4	HEL0180*S4HCA	1/20	4.0	328	4.3	20	600	5.2	2.6	1.3
4	HEL0220*S4HCA	1/20	5.0	410	5.3	20	750	6.5	3.3	1.6
4	HEL0275*S4HCA	1/20	6.0	492	6.3	20	900	7.8	3.9	2.0

FPI	New Model	HP	PSC Motor (Totally Enclosed)				Drain Pan Heaters			
			208-230/1/60				Watts	115/1/60	230/1/60	460/1/60
			Amps	Watts	MCA	MOPD		Total Amps		
6	HEL0040*S6HCA	1/20	0.5	91	0.6	15	150	1.3	0.7	0.3
6	HEL0045*S6HCA	1/20	0.5	91	0.6	15	150	1.3	0.7	0.3
6	HEL0065*S6HCA	1/20	1.0	182	1.1	15	300	2.6	1.3	0.7
6	HEL0080*S6HCA	1/20	1.0	182	1.1	15	300	2.6	1.3	0.7
6	HEL0100*S6HCA	1/20	1.0	182	1.1	15	300	2.6	1.3	0.7
6	HEL0130*S6HCA	1/20	1.5	273	1.6	15	450	3.9	2.0	1.0
6	HEL0155*S6HCA	1/20	1.5	273	1.6	15	450	3.9	2.0	1.0
6	HEL0170*S6HCA	1/20	2.0	364	2.1	15	600	5.2	2.6	1.3
6	HEL0205*S6HCA	1/20	2.0	364	2.1	15	600	5.2	2.6	1.3
6	HEL0240*S6HCA	1/20	2.5	455	2.6	15	750	6.5	3.3	1.6
6	HEL0255*S6HCA	1/20	3.0	546	3.1	15	900	7.8	3.9	2.0
6	HEL0310*S6HCA	1/20	3.0	546	3.1	15	900	7.8	3.9	2.0
4	HEL0045*S4HCA	1/20	0.5	91	0.6	15	150	1.3	0.7	0.3
4	HEL0070*S4HCA	1/20	1.0	182	1.1	15	300	2.6	1.3	0.7
4	HEL0090*S4HCA	1/20	1.0	182	1.1	15	300	2.6	1.3	0.7
4	HEL0135*S4HCA	1/20	1.5	273	1.6	15	450	3.9	2.0	1.0
4	HEL0180*S4HCA	1/20	2.0	364	2.1	15	600	5.2	2.6	1.3
4	HEL0220*S4HCA	1/20	2.5	455	2.6	15	750	6.5	3.3	1.6
4	HEL0275*S4HCA	1/20	3.0	546	3.1	15	900	7.8	3.9	2.0

Notes:

* = Electrical Code Designator (see Nomenclature details)

SPECIFICATIONS

Hot Gas Defrost- 60 Hz

Please consult AWEF table on pages 46 & 47 to confirm model meets DOE minimum AWEF

FPI	New Model	HP	PSC Motor (Totally Enclosed)				Drain Pan Heaters			
			460/1/60				Watts	115/1/60	230/1/60	460/1/60
			Amps	Watts	MCA	MOPD		Total Amps		
6	HEL0040*S6HCA	1/20	0.4	117	0.5	15	150	1.3	0.7	0.3
6	HEL0045*S6HCA	1/20	0.4	117	0.5	15	150	1.3	0.7	0.3
6	HEL0065*S6HCA	1/20	0.8	234	0.9	15	300	2.6	1.3	0.7
6	HEL0080*S6HCA	1/20	0.8	234	0.9	15	300	2.6	1.3	0.7
6	HEL0100*S6HCA	1/20	0.8	234	0.9	15	300	2.6	1.3	0.7
6	HEL0130*S6HCA	1/20	1.2	351	1.3	15	450	3.9	2.0	1.0
6	HEL0155*S6HCA	1/20	1.2	351	1.3	15	450	3.9	2.0	1.0
6	HEL0170*S6HCA	1/20	1.6	468	1.7	15	600	5.2	2.6	1.3
6	HEL0205*S6HCA	1/20	1.6	468	1.7	15	600	5.2	2.6	1.3
6	HEL0240*S6HCA	1/20	2.0	585	2.1	15	750	6.5	3.3	1.6
6	HEL0255*S6HCA	1/20	2.4	702	2.5	15	900	7.8	3.9	2.0
6	HEL0310*S6HCA	1/20	2.4	702	2.5	15	900	7.8	3.9	2.0
4	HEL0045*S4HCA	1/20	0.4	117	0.5	15	150	1.3	0.7	0.3
4	HEL0070*S4HCA	1/20	0.8	234	0.9	15	300	2.6	1.3	0.7
4	HEL0090*S4HCA	1/20	0.8	234	0.9	15	300	2.6	1.3	0.7
4	HEL0135*S4HCA	1/20	1.2	351	1.3	15	450	3.9	2.0	1.0
4	HEL0180*S4HCA	1/20	1.6	468	1.7	15	600	5.2	2.6	1.3
4	HEL0220*S4HCA	1/20	2.0	585	2.1	15	750	6.5	3.3	1.6
4	HEL0275*S4HCA	1/20	2.4	702	2.5	15	900	7.8	3.9	2.0

Notes:

* = Electrical Code Designator (see Nomenclature details)

SPECIFICATIONS

Hot Gas Defrost- 50 Hz

Please consult AWEF table on pages 46 & 47 to confirm model meets DOE minimum AWEF

FPI	New Model	HP	2-Speed EC Motor (Totally Enclosed)				Drain Pan Heaters	
			220/1/50				Watts	220/1/50
			Amps	Watts	MCA	MOPD		Total Amps
6	HEL0040*S6HMA	1/20	0.5	55	0.6	15	135	0.6
6	HEL0045*S6HMA	1/20	0.5	55	0.6	15	135	0.6
6	HEL0065*S6HMA	1/20	1.0	110	1.1	15	275	1.2
6	HEL0080*S6HMA	1/20	1.0	110	1.1	15	275	1.2
6	HEL0100*S6HMA	1/20	1.0	110	1.1	15	275	1.2
6	HEL0130*S6HMA	1/20	1.5	165	1.6	15	410	1.9
6	HEL0155*S6HMA	1/20	1.5	165	1.6	15	410	1.9
6	HEL0170*S6HMA	1/20	2.0	220	2.1	15	550	2.5
6	HEL0205*S6HMA	1/20	2.0	220	2.1	15	550	2.5
6	HEL0240*S6HMA	1/20	2.5	275	2.6	15	690	3.1
6	HEL0255*S6HMA	1/20	3.0	330	3.1	15	825	3.7
6	HEL0310*S6HMA	1/20	3.0	330	3.1	15	825	3.7
4	HEL0045*S4HMA	1/20	0.5	55	0.6	15	135	0.6
4	HEL0070*S4HMA	1/20	1.0	110	1.1	15	275	1.2
4	HEL0090*S4HMA	1/20	1.0	110	1.1	15	275	1.2
4	HEL0135*S4HMA	1/20	1.5	165	1.6	15	410	1.9
4	HEL0180*S4HMA	1/20	2.0	220	2.1	15	550	2.5
4	HEL0220*S4HMA	1/20	2.5	275	2.6	15	690	3.1
4	HEL0275*S4HMA	1/20	3.0	330	3.1	15	825	3.7

FPI	New Model	HP	1-Speed EC Motor (Totally Enclosed)				Drain Pan Heaters	
			220/1/50				Watts	220/1/50
			Amps	Watts	MCA	MOPD		Total Amps
6	HEL0040*S6HEA	1/20	0.5	59	0.6	15	135	0.6
6	HEL0045*S6HEA	1/20	0.5	59	0.6	15	135	0.6
6	HEL0065*S6HEA	1/20	1.0	118	1.1	15	275	1.2
6	HEL0080*S6HEA	1/20	1.0	118	1.1	15	275	1.2
6	HEL0100*S6HEA	1/20	1.0	118	1.1	15	275	1.2
6	HEL0130*S6HEA	1/20	1.5	177	1.6	15	410	1.9
6	HEL0155*S6HEA	1/20	1.5	177	1.6	15	410	1.9
6	HEL0170*S6HEA	1/20	2.0	236	2.1	15	550	2.5
6	HEL0205*S6HEA	1/20	2.0	236	2.1	15	550	2.5
6	HEL0240*S6HEA	1/20	2.5	295	2.6	15	690	3.1
6	HEL0255*S6HEA	1/20	3.0	354	3.1	15	825	3.7
6	HEL0310*S6HEA	1/20	3.0	354	3.1	15	825	3.7
4	HEL0045*S4HEA	1/20	0.5	59	0.6	15	135	0.6
4	HEL0070*S4HEA	1/20	1.0	118	1.1	15	275	1.2
4	HEL0090*S4HEA	1/20	1.0	118	1.1	15	275	1.2
4	HEL0135*S4HEA	1/20	1.5	177	1.6	15	410	1.9
4	HEL0180*S4HEA	1/20	2.0	236	2.1	15	550	2.5
4	HEL0220*S4HEA	1/20	2.5	295	2.6	15	690	3.1
4	HEL0275*S4HEA	1/20	3.0	354	3.1	15	825	3.7

Notes:

* = Electrical Code Designator (see Nomenclature details)

SPECIFICATIONS

Hot Gas Defrost- 50 Hz

Please consult AWEF table on pages 46 & 47 to confirm model meets DOE minimum AWEF

FPI	New Model	HP	PSC Motor (Totally Enclosed)				Drain Pan Heaters	
			220/1/50				Watts	220/1/50
			Amps	Watts	MCA	MOPD		Total Amps
6	HEL0040*S6HCA	1/20	0.5	65	0.6	15	135	0.6
6	HEL0045*S6HCA	1/20	0.5	65	0.6	15	135	0.6
6	HEL0065*S6HCA	1/20	1.0	130	1.1	15	275	1.2
6	HEL0080*S6HCA	1/20	1.0	130	1.1	15	275	1.2
6	HEL0100*S6HCA	1/20	1.0	130	1.1	15	275	1.2
6	HEL0130*S6HCA	1/20	1.5	195	1.6	15	410	1.9
6	HEL0155*S6HCA	1/20	1.5	195	1.6	15	410	1.9
6	HEL0170*S6HCA	1/20	2.0	260	2.1	15	550	2.5
6	HEL0205*S6HCA	1/20	2.0	260	2.1	15	550	2.5
6	HEL0240*S6HCA	1/20	2.5	325	2.6	15	690	3.1
6	HEL0255*S6HCA	1/20	3.0	390	3.1	15	825	3.7
6	HEL0310*S6HCA	1/20	3.0	390	3.1	15	825	3.7
4	HEL0045*S4HCA	1/20	0.5	65	0.6	15	135	0.6
4	HEL0070*S4HCA	1/20	1.0	130	1.1	15	275	1.2
4	HEL0090*S4HCA	1/20	1.0	130	1.1	15	275	1.2
4	HEL0135*S4HCA	1/20	1.5	195	1.6	15	410	1.9
4	HEL0180*S4HCA	1/20	2.0	260	2.1	15	550	2.5
4	HEL0220*S4HCA	1/20	2.5	325	2.6	15	690	3.1
4	HEL0275*S4HCA	1/20	3.0	390	3.1	15	825	3.7

Notes:

* = Electrical Code Designator (see Nomenclature details)

PHYSICAL DATA

Air Defrost (R-404A/R-507A, R-448A/R-449A, R-407A/R-407F, R-407C)

Model	No. of Fans	Coil Inlet OD	Suction OD	Equalizer OD	Drain MPT	Approx. Net Weight	
						lb	kg
HEL0045*S6A^A	1	1/2	1/2	1/4	3/4	33	15
HEL0055*S6A^A	1	1/2	5/8	1/4	3/4	36	16
HEL0060*S6A^A	1	1/2	5/8	1/4	3/4	36	16
HEL0095*S6A^A	2	1/2	5/8	1/4	3/4	51	23
HEL0105*S6A^A	2	1/2	5/8	1/4	3/4	52	24
HEL0115*S6A^A	2	1/2	5/8	1/4	3/4	56	26
HEL0125*S6A^A	2	1/2	7/8	1/4	3/4	56	26
HEL0155*S6A^A	3	1/2	7/8	1/4	3/4	67	30
HEL0190*S6A^A	3	1/2	7/8	1/4	3/4	73	33
HEL0250*S6A^A	4	1/2	7/8	1/4	3/4	94	43
HEL0295*S6A^A	5	1/2	7/8	1/4	3/4	115	52
HEL0350*S6A^A	6	1/2	1-1/8	1/4	3/4	133	60
HEL0380*S6A^A	6	1/2	1-1/8	1/4	3/4	137	62

Air Defrost (CO₂ DX)

Model	No. of Fans	Coil Inlet ²	Suction OD ²	Drain MPT	Approx. Net Weight	
					lb	kg
HEL0045*C6A^A	1	3/8	3/8	3/4	33	15
HEL0055*C6A^A	1	3/8	3/8	3/4	36	16
HEL0060*C6A^A	1	3/8	3/8	3/4	36	16
HEL0095*C6A^A	2	3/8	3/8	3/4	51	23
HEL0105*C6A^A	2	3/8	3/8	3/4	52	24
HEL0115*C6A^A	2	3/8	3/8	3/4	56	26
HEL0125*C6A^A	2	3/8	3/8	3/4	56	26
HEL0155*C6A^A	3	3/8	3/8	3/4	67	30
HEL0190*C6A^A	3	3/8	3/8	3/4	73	33
HEL0250*C6A^A	4	3/8	1/2	3/4	94	43
HEL0295*C6A^A	5	3/8	1/2	3/4	115	52
HEL0350*C6A^A	6	3/8	1/2	3/4	133	60
HEL0380*C6A^A	6	1/2	5/8	3/4	137	62

Notes:

* = Electrical Code Designator (see Nomenclature details)

^ = Motor Code Designator (see Nomenclature details)

² = Connection sizes may vary, if TD is lesser or greater than 10°F

PHYSICAL DATA

Electric Defrost (R-404A/R-507A, R-448A/R-449A, R-407A/R-407F, R-407C)

FPI	Model	No. of Fans	Coil Inlet OD	Suction OD	Equalizer OD	Drain MPT	Approx. Net Weight	
							lb	kg
6	HEL0040*S6E^A	1	1/2	5/8	1/4	3/4	36	16
6	HEL0045*S6E^A	1	1/2	5/8	1/4	3/4	38	17
6	HEL0065*S6E^A	2	1/2	5/8	1/4	3/4	54	24
6	HEL0080*S6E^A	2	1/2	5/8	1/4	3/4	54	24
6	HEL0100*S6E^A	2	1/2	7/8	1/4	3/4	59	27
6	HEL0130*S6E^A	3	1/2	7/8	1/4	3/4	71	32
6	HEL0155*S6E^A	3	1/2	1-1/8	1/4	3/4	78	35
6	HEL0170*S6E^A	4	1/2	7/8	1/4	3/4	91	41
6	HEL0205*S6E^A	4	1/2	1-1/8	1/4	3/4	100	45
6	HEL0240*S6E^A	5	1/2	1-1/8	1/4	3/4	120	54
6	HEL0255*S6E^A	6	1/2	1-1/8	1/4	3/4	134	61
6	HEL0310*S6E^A	6	1/2	1-1/8	1/4	3/4	146	66
4	HEL0045*S4E^A	1	1/2	5/8	1/4	3/4	38	17
4	HEL0070*S4E^A	2	1/2	5/8	1/4	3/4	53	24
4	HEL0090*S4E^A	2	1/2	7/8	1/4	3/4	59	27
4	HEL0135*S4E^A	3	1/2	7/8	1/4	3/4	77	35
4	HEL0180*S4E^A	4	1/2	1-1/8	1/4	3/4	100	45
4	HEL0220*S4E^A	5	1/2	1-1/8	1/4	3/4	119	54
4	HEL0275*S4E^A	6	1/2	1-1/8	1/4	3/4	142	64

Electric Defrost (CO₂ DX)

FPI	Model	No. of Fans	Coil Inlet ²	Suction OD ²	Drain MPT	Approx. Net Weight	
						lb	kg
6	HEL0040*C6E^A	1	3/8	3/8	3/4	36	16
6	HEL0045*C6E^A	1	3/8	3/8	3/4	38	17
6	HEL0065*C6E^A	2	3/8	3/8	3/4	54	24
6	HEL0080*C6E^A	2	3/8	1/2	3/4	54	24
6	HEL0100*C6E^A	2	3/8	1/2	3/4	59	27
6	HEL0130*C6E^A	3	3/8	1/2	3/4	71	32
6	HEL0155*C6E^A	3	3/8	1/2	3/4	78	35
6	HEL0170*C6E^A	4	3/8	1/2	3/4	91	41
6	HEL0205*C6E^A	4	3/8	1/2	3/4	100	45
6	HEL0240*C6E^A	5	3/8	5/8	3/4	120	54
6	HEL0255*C6E^A	6	3/8	5/8	3/4	134	61
6	HEL0310*C6E^A	6	3/8	5/8	3/4	146	66
4	HEL0045*C4E^A	1	3/8	3/8	3/4	38	17
4	HEL0070*C4E^A	2	3/8	3/8	3/4	53	24
4	HEL0090*C4E^A	2	3/8	1/2	3/4	59	27
4	HEL0135*C4E^A	3	3/8	1/2	3/4	77	35
4	HEL0180*C4E^A	4	3/8	1/2	3/4	100	45
4	HEL0220*C4E^A	5	3/8	1/2	3/4	119	54
4	HEL0275*C4E^A	6	3/8	5/8	3/4	142	64

Notes:

* = Electrical Code Designator (see Nomenclature details)

^ = Motor Code Designator (see Nomenclature details)

² = Connection sizes may vary, if TD is lesser or greater than 10°F

PHYSICAL DATA

Hot Gas Defrost

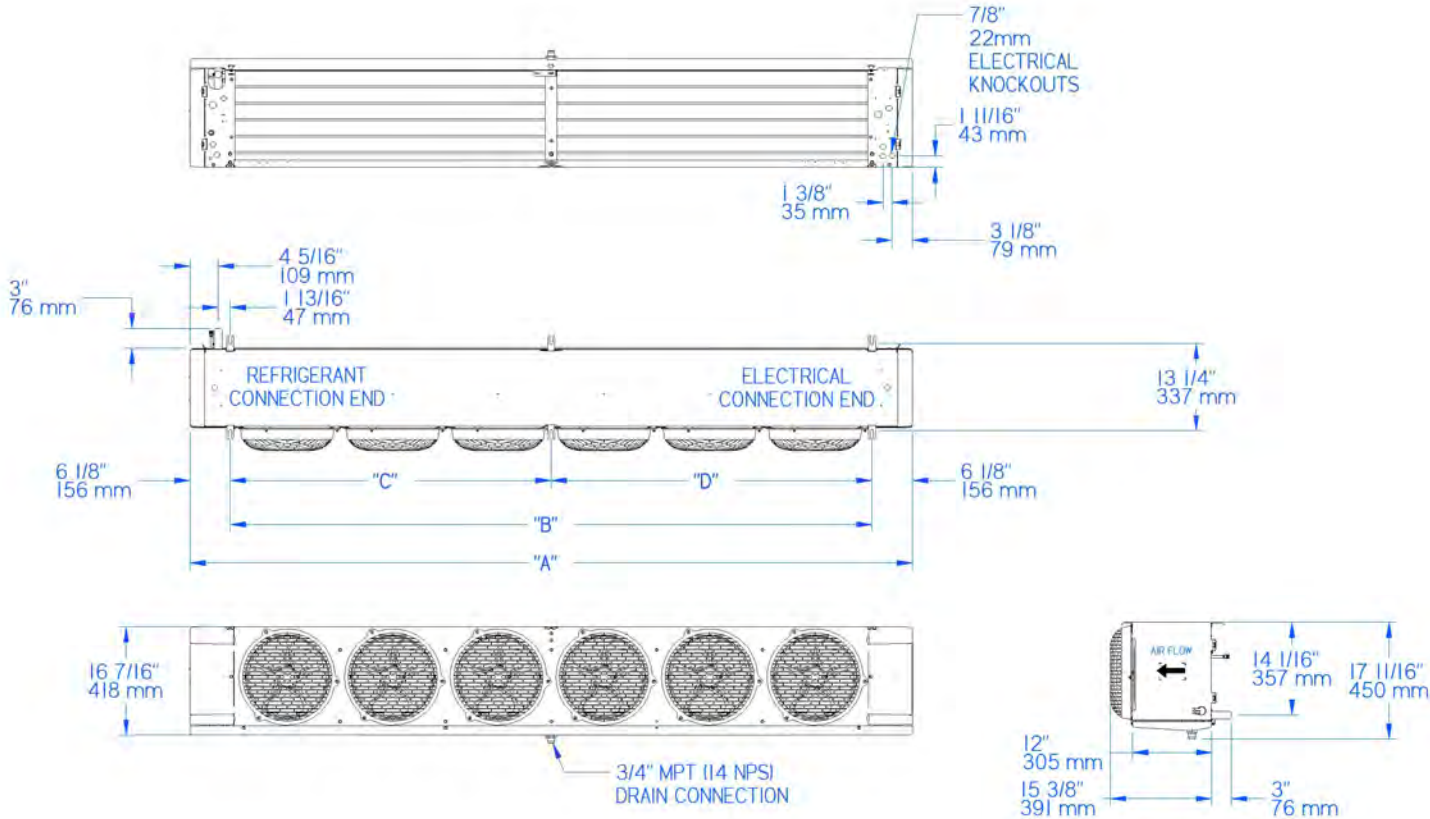
FPI	Model	No. of Fans	Coil Inlet OD	Suction OD	Equalizer OD	Drain MPT	Side Port OD	Hot Gas Pan Connection OD	Approx. Net Weight	
									lb	kg
6	HEL0040*S6H^A	1	1/2	5/8	1/4	3/4	1/2	5/8	38	17
6	HEL0045*S6H^A	1	1/2	5/8	1/4	3/4	1/2	5/8	40	18
6	HEL0065*S6H^A	2	1/2	5/8	1/4	3/4	1/2	5/8	56	25
6	HEL0080*S6H^A	2	1/2	5/8	1/4	3/4	1/2	5/8	56	25
6	HEL0100*S6H^A	2	1/2	7/8	1/4	3/4	1/2	5/8	61	27
6	HEL0130*S6H^A	3	1/2	7/8	1/4	3/4	1/2	5/8	73	33
6	HEL0155*S6H^A	3	1/2	1-1/8	1/4	3/4	1/2	5/8	80	36
6	HEL0170*S6H^A	4	1/2	7/8	1/4	3/4	1/2	5/8	93	42
6	HEL0205*S6H^A	4	1/2	1-1/8	1/4	3/4	1/2	5/8	102	46
6	HEL0240*S6H^A	5	1/2	1-1/8	1/4	3/4	1/2	5/8	122	55
6	HEL0255*S6H^A	6	1/2	1-1/8	1/4	3/4	1/2	5/8	136	62
6	HEL0310*S6H^A	6	1/2	1-1/8	1/4	3/4	1/2	5/8	148	67
4	HEL0045*S4H^A	1	1/2	5/8	1/4	3/4	1/2	5/8	40	18
4	HEL0070*S4H^A	2	1/2	5/8	1/4	3/4	1/2	5/8	55	25
4	HEL0090*S4H^A	2	1/2	7/8	1/4	3/4	1/2	5/8	61	28
4	HEL0135*S4H^A	3	1/2	7/8	1/4	3/4	1/2	5/8	79	36
4	HEL0180*S4H^A	4	1/2	1-1/8	1/4	3/4	1/2	5/8	102	46
4	HEL0220*S4H^A	5	1/2	1-1/8	1/4	3/4	1/2	5/8	121	55
4	HEL0275*S4H^A	6	1/2	1-1/8	1/4	3/4	1/2	5/8	144	65

Notes:

* = Electrical Code Designator (see Nomenclature details)

^ = Motor Code Designator (see Nomenclature details)

DIMENSIONAL DRAWINGS



No. of Fans	A		B		C		D	
	in.	mm	in.	mm	in.	mm	in.	mm
1	29.5	749	17.25	438	-	-	-	-
2	45.5	1,156	33.25	845	-	-	-	-
3	61.5	1,562	49.25	1,251	-	-	-	-
4	77.5	1,969	65.25	1,657	-	-	-	-
5	93.5	2,375	81.25	2,064	48.63	1,235	32.63	829
6	109.5	2,781	97.25	2,470	48.63	1,235	48.63	1,235

Note:
Hanger brackets will accept 3/8" / 9.5 mm hanger rods

DOE Rated AWEF

AWEF DATA

Air Defrost/2-Speed EC Motors

FPI	Model	Cooler				
		R-404A/ R-507A	R-448A/ R-449A	R-407A/ R-407F	R-407C	CO ₂ DX
		AWEF	AWEF	AWEF	AWEF	AWEF
6	HEL0045*S6AMA	9.00	9.00	9.00	9.00	9.00
6	HEL0055*S6AMA	9.00	9.00	9.00	9.00	9.00
6	HEL0060*S6AMA	9.00	9.00	9.00	9.00	9.00
6	HEL0095*S6AMA	9.00	9.00	9.00	9.00	9.00
6	HEL0105*S6AMA	9.00	9.00	9.00	9.00	9.00
6	HEL0115*S6AMA	9.00	9.00	9.00	9.00	9.00
6	HEL0125*S6AMA	9.00	9.00	9.00	9.00	9.00
6	HEL0155*S6AMA	9.00	9.00	9.00	9.00	9.00
6	HEL0190*S6AMA	9.00	9.00	9.00	9.00	9.00
6	HEL0250*S6AMA	9.00	9.00	9.00	9.00	9.00
6	HEL0295*S6AMA	9.00	9.00	9.00	9.00	9.00
6	HEL0350*S6AMA	9.00	9.00	9.00	9.00	9.00
6	HEL0380*S6AMA	9.00	9.00	9.00	9.00	9.00

DOE Rated AWEF

AWEF DATA

Electric Defrost/1-Speed EC Motors

FPI	Model	Freezer				
		R-404A/ R-507A	R-448A/ R-449A	R-407A/ R-407F	R-407C	CO ₂ DX
		AWEF	AWEF	AWEF	AWEF	AWEF
6	HEL0040*S6EEA	3.96	3.96	3.96	-	3.96
6	HEL0045*S6EEA	3.96	3.96	3.96	-	3.96
6	HEL0065*S6EEA	4.00	4.03	4.02	-	4.00
6	HEL0080*S6EEA	4.03	4.03	4.03	-	4.03
6	HEL0100*S6EEA	4.00	4.06	4.06	-	4.00
6	HEL0130*S6EEA	4.09	4.09	4.09	-	4.09
6	HEL0155*S6EEA	4.10	4.10	4.10	-	4.10
6	HEL0170*S6EEA	4.14	4.14	4.14	-	4.14
6	HEL0205*S6EEA	4.15	4.15	4.15	-	4.15
6	HEL0240*S6EEA	4.15	4.15	4.15	-	4.15
6	HEL0255*S6EEA	4.15	4.15	4.15	-	4.15
6	HEL0310*S6EEA	4.15	4.15	4.15	-	4.15
4	HEL0045*S4EEA	3.96	3.96	3.96	-	3.96
4	HEL0070*S4EEA	3.99	3.99	3.99	-	-
4	HEL0090*S4EEA	4.02	4.02	4.02	-	4.02
4	HEL0135*S4EEA	4.07	4.07	4.07	-	4.07
4	HEL0180*S4EEA	4.12	4.12	4.12	-	4.12
4	HEL0220*S4EEA	4.15	4.15	4.15	-	4.15
4	HEL0275*S4EEA	4.15	4.15	4.15	-	4.15

DOE Rated AWEF

AWEF DATA

Electric Defrost/2-Speed EC Motors

FPI	Model	Cooler				
		R-404A/ R-507A	R-448A/ R-449A	R-407A/ R-407F	R-407C	CO ₂ DX
		AWEF	AWEF	AWEF	AWEF	AWEF
6	HEL0040*±6EMA	9.00	9.00	9.00	-	9.00
6	HEL0045*±6EMA	9.00	9.00	9.00	-	9.00
6	HEL0065*±6EMA	9.00	9.00	9.00	-	9.00
6	HEL0080*±6EMA	9.00	9.00	9.00	-	9.00
6	HEL0100*±6EMA	9.00	9.00	9.00	-	9.00
6	HEL0130*±6EMA	9.00	9.00	9.00	-	9.00
6	HEL0155*±6EMA	9.00	9.00	9.00	-	9.00
6	HEL0170*±6EMA	9.00	9.00	9.00	-	9.00
6	HEL0205*±6EMA	9.00	9.00	9.00	-	9.00
6	HEL0240*±6EMA	9.00	9.00	9.00	-	9.00
6	HEL0255*±6EMA	9.00	9.00	9.00	-	9.00
6	HEL0310*±6EMA	9.00	9.00	9.00	-	9.00
4	HEL0045*±4EMA	9.00	9.00	9.00	-	9.00
4	HEL0070*±4EMA	9.00	9.00	9.00	-	-
4	HEL0090*±4EMA	9.00	9.00	9.00	-	9.00
4	HEL0135*±4EMA	9.00	9.00	9.00	-	9.00
4	HEL0180*±4EMA	9.00	9.00	9.00	-	9.00
4	HEL0220*±4EMA	9.00	9.00	9.00	-	9.00
4	HEL0275*±4EMA	9.00	9.00	9.00	-	9.00

FPI	Model	Freezer				
		R-404A/ R-507A	R-448A/ R-449A	R-407A/ R-407F	R-407C	CO ₂ DX
		AWEF	AWEF	AWEF	AWEF	AWEF
6	HEL0040*±6EMA	3.96	3.96	3.96	-	3.96
6	HEL0045*±6EMA	3.96	3.96	3.96	-	3.96
6	HEL0065*±6EMA	4.00	4.03	4.02	-	4.00
6	HEL0080*±6EMA	4.00	4.00	4.00	-	4.00
6	HEL0100*±6EMA	4.03	4.03	4.03	-	4.03
6	HEL0130*±6EMA	4.06	4.06	4.06	-	4.06
6	HEL0155*±6EMA	4.09	4.09	4.09	-	4.09
6	HEL0170*±6EMA	4.10	4.10	4.10	-	4.10
6	HEL0205*±6EMA	4.14	4.14	4.14	-	4.14
6	HEL0240*±6EMA	4.15	4.15	4.15	-	4.15
6	HEL0255*±6EMA	4.15	4.15	4.15	-	4.15
6	HEL0310*±6EMA	4.15	4.15	4.15	-	4.15
4	HEL0045*±4EMA	3.96	3.96	3.96	-	3.96
4	HEL0070*±4EMA	3.99	3.99	3.99	-	-
4	HEL0090*±4EMA	4.02	4.02	4.02	-	4.02
4	HEL0135*±4EMA	4.07	4.07	4.07	-	4.07
4	HEL0180*±4EMA	4.12	4.12	4.12	-	4.12
4	HEL0220*±4EMA	4.15	4.15	4.15	-	4.15
4	HEL0275*±4EMA	4.15	4.15	4.15	-	4.15

DOE Rated AWEF

AWEF DATA

Hot Gas Defrost/1-Speed EC Motors

FPI	Model	Freezer			
		R-404A/ R-507A	R-448A/ R-449A	R-407A/ R-407F	R-407C
		AWEF	AWEF	AWEF	AWEF
6	HEL0040*S6HEA	3.96	3.96	3.96	-
6	HEL0045*S6HEA	3.96	3.96	3.96	-
6	HEL0065*S6HEA	4.00	4.03	4.02	-
6	HEL0080*S6HEA	4.03	4.03	4.03	-
6	HEL0100*S6HEA	4.06	4.06	4.06	-
6	HEL0130*S6HEA	4.09	4.09	4.09	-
6	HEL0155*S6HEA	4.10	4.10	4.10	-
6	HEL0170*S6HEA	4.14	4.14	4.14	-
6	HEL0205*S6HEA	4.15	4.15	4.15	-
6	HEL0240*S6HEA	4.15	4.15	4.15	-
6	HEL0255*S6HEA	4.15	4.15	4.15	-
6	HEL0310*S6HEA	4.15	4.15	4.15	-
4	HEL0045*S4HEA	3.96	3.96	3.96	-
4	HEL0070*S4HEA	3.99	3.99	3.99	-
4	HEL0090*S4HEA	4.02	4.02	4.02	-
4	HEL0135*S4HEA	4.07	4.07	4.07	-
4	HEL0180*S4HEA	4.12	4.12	4.12	-
4	HEL0220*S4HEA	4.15	4.15	4.15	-
4	HEL0275*S4HEA	4.15	4.15	4.15	-

DOE Rated AWEF

AWEF DATA

Hot Gas Defrost/2-Speed EC Motors

FPI	Model	Cooler			
		R-404A/ R-507A	R-448A/ R-449A	R-407A/ R-407F	R-407C
		AWEF	AWEF	AWEF	AWEF
6	HEL0040*S6HMA	9.00	9.00	9.00	-
6	HEL0045*S6HMA	9.00	9.00	9.00	-
6	HEL0065*S6HMA	9.00	9.00	9.00	-
6	HEL0080*S6HMA	9.00	9.00	9.00	-
6	HEL0100*S6HMA	9.00	9.00	9.00	-
6	HEL0130*S6HMA	9.00	9.00	9.00	-
6	HEL0155*S6HMA	9.00	9.00	9.00	-
6	HEL0170*S6HMA	9.00	9.00	9.00	-
6	HEL0205*S6HMA	9.00	9.00	9.00	-
6	HEL0240*S6HMA	9.00	9.00	9.00	-
6	HEL0255*S6HMA	9.00	9.00	9.00	-
6	HEL0310*S6HMA	9.00	9.00	9.00	-
4	HEL0045*S4HMA	9.00	9.00	9.00	-
4	HEL0070*S4HMA	9.00	9.00	9.00	-
4	HEL0090*S4HMA	9.00	9.00	9.00	-
4	HEL0135*S4HMA	9.00	9.00	9.00	-
4	HEL0180*S4HMA	9.00	9.00	9.00	-
4	HEL0220*S4HMA	9.00	9.00	9.00	-
4	HEL0275*S4HMA	9.00	9.00	9.00	-

FPI	Model	Freezer			
		R-404A/ R-507A	R-448A/ R-449A	R-407A/ R-407F	R-407C
		AWEF	AWEF	AWEF	AWEF
6	HEL0040*S6HMA	3.96	3.96	3.96	-
6	HEL0045*S6HMA	3.96	3.96	3.96	-
6	HEL0065*S6HMA	4.00	4.03	4.02	-
6	HEL0080*S6HMA	4.00	4.00	4.00	-
6	HEL0100*S6HMA	4.03	4.03	4.03	-
6	HEL0130*S6HMA	4.06	4.06	4.06	-
6	HEL0155*S6HMA	4.09	4.09	4.09	-
6	HEL0170*S6HMA	4.10	4.10	4.10	-
6	HEL0205*S6HMA	4.14	4.14	4.14	-
6	HEL0240*S6HMA	4.15	4.15	4.15	-
6	HEL0255*S6HMA	4.15	4.15	4.15	-
6	HEL0310*S6HMA	4.15	4.15	4.15	-
4	HEL0045*S4HMA	3.96	3.96	3.96	-
4	HEL0070*S4HMA	3.99	3.99	3.99	-
4	HEL0090*S4HMA	4.02	4.02	4.02	-
4	HEL0135*S4HMA	4.07	4.07	4.07	-
4	HEL0180*S4HMA	4.12	4.12	4.12	-
4	HEL0220*S4HMA	4.15	4.15	4.15	-
4	HEL0275*S4HMA	4.15	4.15	4.15	-

HOT GAS REVERSE CYCLE KITS

Shipped Loose Accessories

FPI	Model	TXV Bypass and Liquid Line Piping Kit (Reverse Cycle)	TXV Liquid Line Piping Kit (Three Pipe or Rev Cycle w/o TXV Bypass)	Suction/Drain Pan Check Valve Piping Kit (Reverse Cycle)	Drain Pan Check Valve Piping Kit (Three Pipe)
		For TXV's SBF/SQE/BBI/EG	For TXV's SBF/SQE/BBI/EG		
6	HEL0040*S6H^A	50756301	50756302	50692204	50692302
6	HEL0045*S6H^A	50756301	50756302	50692204	50692302
6	HEL0065*S6H^A	50756301	50756302	50692204	50692302
6	HEL0080*S6H^A	50756301	50756302	50692204	50692302
6	HEL0100*S6H^A	50756301	50756302	50692225	50692302
6	HEL0130*S6H^A	50756301	50756302	50692225	50692302
6	HEL0155*S6H^A	50756301	50756302	50692206	50692302
6	HEL0170*S6H^A	50756301	50756302	50692205	50692302
6	HEL0205*S6H^A	50756301	50756302	50692206	50692302
6	HEL0240*S6H^A	50756301	50756302	50692206	50692302
6	HEL0255*S6H^A	50756301	50756302	50692206	50692302
6	HEL0310*S6H^A	50756301	50756302	50692206	50692302
4	HEL0045*S4H^A	50756301	50756302	50692204	50692302
4	HEL0070*S4H^A	50756301	50756302	50692204	50692302
4	HEL0090*S4H^A	50756301	50756302	50692205	50692302
4	HEL0135*S4H^A	50756301	50756302	50692205	50692302
4	HEL0180*S4H^A	50756301	50756302	50692206	50692302
4	HEL0220*S4H^A	50756301	50756302	50692206	50692302
4	HEL0275*S4H^A	50756301	50756302	50692206	50692302

REVERSE CYCLE PIPING

Reverse cycle defrost unit cooler operation

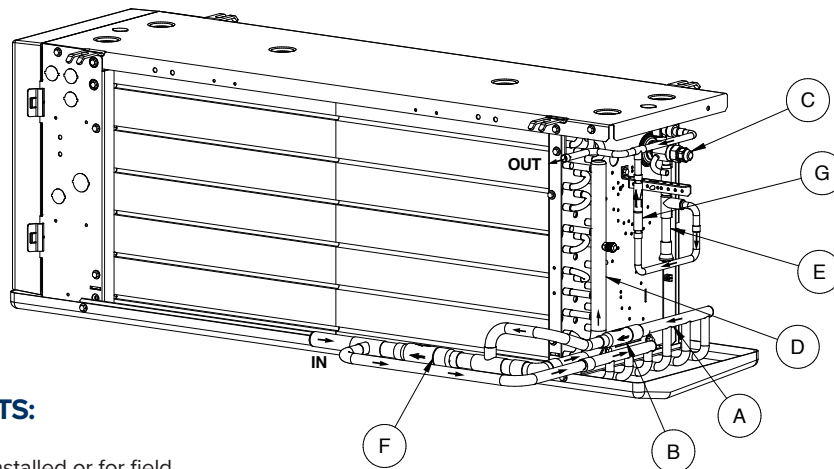
Reverse cycle defrost is a common method used in systems that include at least four unit coolers connected to a compressor rack. No more than 25% of the connected unit coolers are typically defrosted at the same time.

During reverse cycle, valving at the compressor rack diverts hot gas through the suction line to the defrosting unit cooler. See piping view in Figure 1. The suction line check valve directs the hot gas through the pan loop; heating the drain pan and preventing condensate from freezing during defrost. The hot gas exits the loop at the pan loop outlet header, passes through the drain pan check valve and enters the evaporator coil through the coil suction header. The hot refrigerant gas then flows through the defrosting coil, heating the finned surface and melting frost. As heat is transferred to the coil fins, hot refrigerant gas condenses to a liquid state. The refrigerant then exits the coil at the distributor side port, passes around the expansion valve through the bypass check valve and flows into the liquid refrigerant line. The liquid refrigerant then feeds other evaporators on the cooling cycle, evaporates, and returns to the compressor through their suction lines.

In some systems, electric drain pan heaters are used instead of a hot gas pan loop. Hot gas piping is simplified with the suction and drain pan check valves being eliminated. Electric drain pan heaters are energized during the defrost period, by a defrost control on the unit cooler or by a compressor rack controller.

REVERSE CYCLE DEFROST PIPING KEY COMPONENTS (FIG. 1)

- A. Hot gas drain pan loop
- B. Drain pan check valve
- C. Expansion valve
- D. Suction header
- E. Distributor
- F. Suction check valve
- G. Expansion valve bypass check valve



REVERSE CYCLE DEFROST PIPING KITS:

External check valve kit (available factory-installed or for field installation) includes suction check valve, drain pan check valve and piping to connect to suction header and hot gas drain pan loop. This kit is only necessary when the unit cooler is equipped with a hot gas drain pan loop.

Expansion valve bypass kit (available factory-installed or for field installation) includes expansion valve bypass check valve and piping to connect to the distributor side port and liquid line piping. The factory-installed version includes the expansion valve.

Use of external liquid/suction line heat exchanger with a reverse cycle system:

To increase the efficiency, higher performance and greater system protection, a heat exchanger may be beneficial to the system. In order to use a heat exchanger, the expansion valve bypass piping must be modified. See the piping view in Figure 2. The modification includes rerouting the pipe from the expansion valve bypass check valve to the inlet connection of the liquid line to the heat exchanger. A pipe needs to be routed from the liquid line outlet connection of the heat exchanger to the inlet connection of the thermostatic expansion valve.

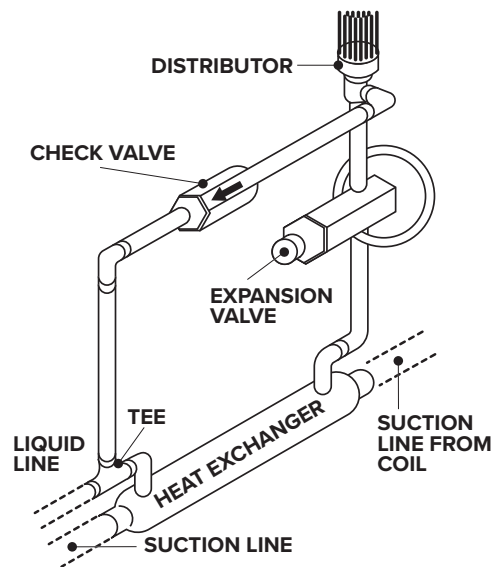


FIGURE 2. Typical Liquid Line Bypass Kit
(Shown assembled and modified for heat exchanger)

Three-pipe defrost unit cooler operation

Three-pipe defrost systems are connected to either a condensing unit or a compressor rack. No more than 33% of the connected unit coolers are typically defrosted at the same time.

During defrost, hot gas is directed through dedicated refrigerant piping (third pipe) to the defrosting unit cooler. See piping view in Figure 3. The hot gas enters the drain pan loop; heating the drain pan and preventing condensate from freezing during defrost. The hot gas exits the loop at the pan loop outlet header, passes through the drain pan check valve and enters the evaporator coil through the distributor side port connection. The hot refrigerant gas then flows through the defrosting coil, heating the finned surface and melting frost. As heat is transferred to the coil fins, hot refrigerant gas condenses to a liquid state. The refrigerant then exits the coil at the suction header.

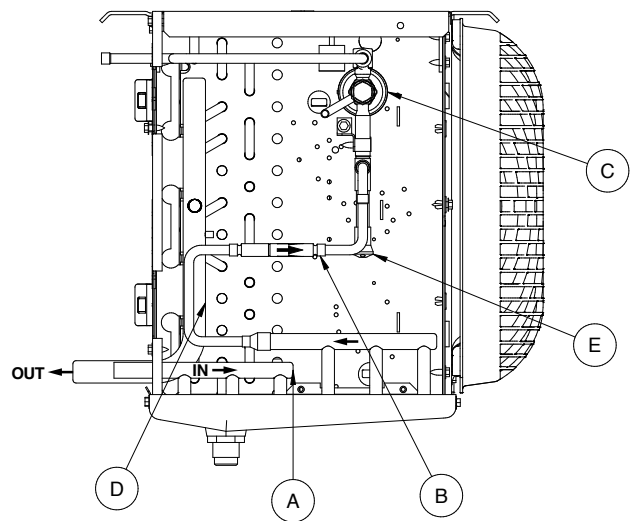
Three-pipe defrost unit cooler operation (cont.)

In some systems, electric drain pan heaters are used instead of a hot gas pan loop. Hot gas piping is simplified with the drain pan check valve being eliminated. Electric drain pan heaters are energized during the defrost period, by a defrost control on the unit cooler or by a compressor rack controller.

In order to provide sufficient re-evaporation of the liquid vapor mixture and sufficient heat for defrost, no more than one-third of the system should be defrosted at one time. Some means of control in the 3-pipe hot gas system should be supplied to regulate the large amount of liquid returning to the compressor, refrigerant slugging can otherwise damage the compressor.

REVERSE CYCLE THREE-PIPE DEFROST PIPING KEY COMPONENTS (FIG. 3)

- A. Hot gas drain pan loop
- B. Drain pan check valve
- C. Expansion valve
- D. Suction header
- E. Distributor



THREE-PIPE DEFROST PIPING KIT:

Three-pipe check valve kit (available factory-installed or for field installation) includes drain pan check valve and piping to connect the distributor side port to the hot gas drain pan loop. This kit is only necessary when the unit cooler is equipped with a hot gas drain pan loop.

Hot gas defrost controls:

Hot gas unit coolers are factory equipped with temperature control(s) that terminate the defrost cycle when the evaporator coil is clear of frost. After defrost, the control(s) keep the evaporator fans from re-energizing until the coil temperature is close to the freezing point.

STANDARD:

The standard control scheme includes an electromechanical defrost termination / fan delay control.

For reverse cycle defrost, the control sensing bulb is placed on the expansion valve bypass line, between the distributor side port and the expansion valve bypass check valve.

For three-pipe defrost, the control sensing bulb is placed on the suction header or suction header outlet connection.

OPTIONAL:

The optional control scheme includes an electromechanical defrost termination control and a separate bimetallic fan delay control. This scheme provides more options for the placement of the control sensing bulb as the defrost termination and fan delay sensing points are no longer combined.

The fan delay temperature is sensed on the evaporator coil endplate adjacent to the fins.

For reverse cycle defrost, the control sensing bulb is placed on the expansion valve bypass line or liquid line piping adjacent to the unit cooler.

For three-pipe defrost, the control sensing bulb is placed on the suction header or suction header outlet connection.

REPLACEMENT PARTS

Motor/Motor Mounts

Part #	Motor Type	Voltage	Motor Speeds	Motor Mount
25312501S / 25329001S	EC	115	1-SP / 2-SP	23108401*
25312601S / 25329101S	EC	208-230	2-SP	23108401*
25317701S	EC	208-230	1-SP	23108401
25309501S	PSC	115	1-SP	23108401
25309801S	PSC	208-230	1-SP	23108401
25309701S	PSC	460	1-SP	23106401

* = Consult factory when replacing motor mounts for motors 25329001S / 23529101S

Fan Blade

Part #	Description
5140C	Fan Blade 12" Std
5110E	Fan Blade 12" Reverse Air Flow

Fan Guard

Part #	Description
37001601	Fan Guard Wire Blue
37001801	Fan Guard Molded Blue

Cabinet Components

Part #	No. of Fans	Description	Defrost Type	Cabinet Aluminum	Application Notes
40594101	1	Drain Pan	Air/Hot Gas	Aluminum	Air, Hot Gas Models w/Drain Pan Loop
40595101	1	Drain Pan	Air/Hot Gas	White Painted Aluminum	Air, Hot Gas Models w/Drain Pan Loop
40596101	1	Drain Pan	Air/Hot Gas	Stainless Steel	Air Defrost Only
40594201	2	Drain Pan	Air/Hot Gas	Aluminum	Air, Hot Gas Models w/Drain Pan Loop
40595201	2	Drain Pan	Air/Hot Gas	White Painted Aluminum	Air, Hot Gas Models w/Drain Pan Loop
40596201	2	Drain Pan	Air/Hot Gas	Stainless Steel	Air Defrost Only
40594301	3	Drain Pan	Air/Hot Gas	Aluminum	Air, Hot Gas Models w/Drain Pan Loop
40595301	4	Drain Pan	Air/Hot Gas	White Painted Aluminum	Air, Hot Gas Models w/Drain Pan Loop
40596301	4	Drain Pan	Air/Hot Gas	Stainless Steel	Air Defrost Only
40594401	4	Drain Pan	Air/Hot Gas	Aluminum	Air, Hot Gas Models w/Drain Pan Loop
40595401	4	Drain Pan	Air/Hot Gas	White Painted Aluminum	Air, Hot Gas Models w/Drain Pan Loop
40596401	4	Drain Pan	Air/Hot Gas	Stainless Steel	Air Defrost Only
40594501	5	Drain Pan	Air/Hot Gas	Aluminum	Air, Hot Gas Models w/Drain Pan Loop
40595501	5	Drain Pan	Air/Hot Gas	White Painted Aluminum	Air, Hot Gas Models w/Drain Pan Loop
40596501	5	Drain Pan	Air/Hot Gas	Stainless Steel	Air Defrost Only
40594601	6	Drain Pan	Air/Hot Gas	Aluminum	Air, Hot Gas Models w/Drain Pan Loop
40595601	6	Drain Pan	Air/Hot Gas	White Painted Aluminum	Air, Hot Gas Models w/Drain Pan Loop
40596601	6	Drain Pan	Air/Hot Gas	Stainless Steel	Air Defrost Only

REPLACEMENT PARTS

Cabinet Components (cont.)

Part #	No. of Fans	Description	Defrost Type	Cabinet Aluminum	Application Notes
40594102	1	Drain Pan	Electric/Hot Gas	Aluminum	Elec, Hot Gas Models w/Drain Pan Heater
40595102	1	Drain Pan	Electric/Hot Gas	White Painted Aluminum	Elec, Hot Gas Models w/Drain Pan Heater
40594202	2	Drain Pan	Electric/Hot Gas	Aluminum	Elec, Hot Gas Models w/Drain Pan Heater
40595202	2	Drain Pan	Electric/Hot Gas	White Painted Aluminum	Elec, Hot Gas Models w/Drain Pan Heater
40594302	3	Drain Pan	Electric/Hot Gas	Aluminum	Elec, Hot Gas Models w/Drain Pan Heater
40595302	3	Drain Pan	Electric/Hot Gas	White Painted Aluminum	Elec, Hot Gas Models w/Drain Pan Heater
40594402	4	Drain Pan	Electric/Hot Gas	Aluminum	Elec, Hot Gas Models w/Drain Pan Heater
40595402	4	Drain Pan	Electric/Hot Gas	White Painted Aluminum	Elec, Hot Gas Models w/Drain Pan Heater
40594502	5	Drain Pan	Electric/Hot Gas	Aluminum	Elec, Hot Gas Models w/Drain Pan Heater
40595502	5	Drain Pan	Electric/Hot Gas	White Painted Aluminum	Elec, Hot Gas Models w/Drain Pan Heater
40594602	6	Drain Pan	Electric/Hot Gas	Aluminum	Elec, Hot Gas Models w/Drain Pan Heater
40595602	6	Drain Pan	Electric/Hot Gas	White Painted Aluminum	Elec, Hot Gas Models w/Drain Pan Heater
40593703	1	Insulated Outer Drain Pan Assy	All	Aluminum	Includes Outer Cover and Insulation
40593704	1	Insulated Outer Drain Pan Assy	All	White Painted Aluminum	Includes Outer Cover and Insulation
40593002	1	Insulated Outer Drain Pan Assy	All	Stainless Steel	Includes Outer Cover and Insulation
40593803	2	Insulated Outer Drain Pan Assy	All	Aluminum	Includes Outer Cover and Insulation
40593804	2	Insulated Outer Drain Pan Assy	All	White Painted Aluminum	Includes Outer Cover and Insulation
40593102	2	Insulated Outer Drain Pan Assy	All	Stainless Steel	Includes Outer Cover and Insulation
40591503	3	Insulated Outer Drain Pan Assy	All	Aluminum	Includes Outer Cover and Insulation
40591504	3	Insulated Outer Drain Pan Assy	All	White Painted Aluminum	Includes Outer Cover and Insulation
40593202	3	Insulated Outer Drain Pan Assy	All	Stainless Steel	Includes Outer Cover and Insulation
40591603	4	Insulated Outer Drain Pan Assy	All	Aluminum	Includes Outer Cover and Insulation
40591604	4	Insulated Outer Drain Pan Assy	All	White Painted Aluminum	Includes Outer Cover and Insulation
40593302	4	Insulated Outer Drain Pan Assy	All	Stainless Steel	Includes Outer Cover and Insulation
40591703	5	Insulated Outer Drain Pan Assy	All	Aluminum	Includes Outer Cover and Insulation
40591704	5	Insulated Outer Drain Pan Assy	All	White Painted Aluminum	Includes Outer Cover and Insulation
40593402	5	Insulated Outer Drain Pan Assy	All	Stainless Steel	Includes Outer Cover and Insulation
40591803	6	Insulated Outer Drain Pan Assy	All	Aluminum	Includes Outer Cover and Insulation

REPLACEMENT PARTS

Cabinet Components (cont.)

Part #	No. of Fans	Description	Defrost Type	Cabinet Aluminum	Application Notes
40591804	6	Insulated Outer Drain Pan Assy	All	White Painted Aluminum	Includes Outer Cover and Insulation
40593502	6	Insulated Outer Drain Pan Assy	All	Stainless Steel	Includes Outer Cover and Insulation
41032901	All	Access Panel RH (Elect) End	All	Aluminum/Stainless Steel	All w/Unpainted Cabinet
41032902	All	Access Panel RH (Elect) End	All	White Painted Aluminum	All w/White Cabinet
41032801	All	Access Panel LH (Refrig) End	All	Aluminum/Stainless Steel	Standard w/Unpainted Cabinet
41032802	All	Access Panel LH (Refrig) End	All	White Painted Aluminum	Standard w/White Cabinet
41032803	All	Access Panel LH (Refrig) End	Air/Electric	Aluminum/Stainless Steel	IntelliGen/QRC/Beacon II w/Unpainted Cabinet
41032804	All	Access Panel LH (Refrig) End	Air/Electric	White Painted Aluminum	IntelliGen/QRC/Beacon II w/White Cabinet
41038401	All	Access Panel LH (Refrig) End	Air/Electric	Aluminum	Glycol/CO ₂ Overfeed Only
41038402	All	Access Panel LH (Refrig) End	Air/Electric	White Painted Aluminum	Glycol/CO ₂ Overfeed Only
41038501	All	Access Panel LH (Refrig) End	Air/Electric	Stainless Steel	Glycol/CO ₂ Overfeed Only
41038701	All	Access Panel RH (Elect) End	Air/Electric	Aluminum	Glycol/CO ₂
41038702	All	Access Panel RH (Elect) End	Air/Electric	White Painted Aluminum	Glycol/CO ₂
41038901	All	Access Panel RH (Elect) End	Air/Electric	Stainless Steel	Glycol/CO ₂

Drain Pan Heaters

Part #	No. of Fans	Voltage	Wattage	Defrost Type	Application Notes
24753101	1	115	150	Hot Gas	Hot Gas Models w/Drain Pan Heater
24753102	2	115	300	Hot Gas	Hot Gas Models w/Drain Pan Heater
24753103	3	115	450	Hot Gas	Hot Gas Models w/Drain Pan Heater
24753104	4	115	600	Hot Gas	Hot Gas Models w/Drain Pan Heater
24753105	5	115	750	Hot Gas	Hot Gas Models w/Drain Pan Heater
24753106	6	115	900	Hot Gas	Hot Gas Models w/Drain Pan Heater
24752501	1	230	150	Electric /Hot Gas	Elec, Hot Gas Models w/Drain Pan Heater
24752502	2	230	300	Electric /Hot Gas	Elec, Hot Gas Models w/Drain Pan Heater
24752503	3	230	450	Electric /Hot Gas	Elec, Hot Gas Models w/Drain Pan Heater
24752504	4	230	600	Electric /Hot Gas	Elec, Hot Gas Models w/Drain Pan Heater
24752505	5	230	750	Electric /Hot Gas	Elec, Hot Gas Models w/Drain Pan Heater
24752506	6	230	900	Electric /Hot Gas	Elec, Hot Gas Models w/Drain Pan Heater
24753201	1	460	150	Hot Gas	Hot Gas Models w/Drain Pan Heater
24753202	2	460	300	Hot Gas	Hot Gas Models w/Drain Pan Heater
24753203	3	460	450	Hot Gas	Hot Gas Models w/Drain Pan Heater
24753204	4	460	600	Hot Gas	Hot Gas Models w/Drain Pan Heater
24753205	5	460	750	Hot Gas	Hot Gas Models w/Drain Pan Heater
24753206	6	460	900	Hot Gas	Hot Gas Models w/Drain Pan Heater

REPLACEMENT PARTS

Coil Defrost Heaters

Part #	No. of Fans	Voltage	Wattage	Defrost Type
24752001	1	230	300	Electric
24752002	2	230	600	Electric
24752003	3	230	900	Electric
24752004	4	230	1,200	Electric
24752005	5	230	1,500	Electric
24752006	6	230	1,800	Electric
24754101*	1	230	150	Electric
24754102*	2	230	300	Electric
24754103*	3	230	450	Electric
24754104*	4	230	600	Electric
24754105*	5	230	750	Electric
24754106*	6	230	900	Electric

* = One used per 460V unit only, top coil heater position

Electrical Components

Part #	Description	Defrost Type	Application Notes
22597101	Terminal Board	Air	All
22597701	Terminal Board	Electric/Hot Gas	All
5709L	Defrost Termination/Fan Delay Thermostat	Electric	Fixed Bi-Metallic Control
5708L	Heater Limit Thermostat	Electric	Fixed Bi-Metallic Control
4267W	Defrost Termination/Fan Delay Thermostat	Electric/Hot Gas	Adjustable Control
28913901	Room Thermostat	Air/Electric	Room Thermostat Mech
28963201	Room Thermostat	Air/Electric	Room Thermostat Elec

Drain Fitting

Part #	Description	Application Notes
26925101	Drain Fitting Kit	All

STANDARD NOZZLE SELECTION

Air Defrost

Medium Temperature (25°F SST)								
Model	No. of Fans	Distributor Tube (in.)		No. of Circuits	Nozzle Selections			
		OD	Length		R-404A/R-507A	R-448A/R-449A	R-407A/R-407F	R-407C
HEL0045*S6A^A	1	3/16	15	1	-	-	-	-
HEL0055*S6A^A	1	3/16	15	2	L-1/3	L-1/2	L-1/3	L-1/3
HEL0060*S6A^A	1	3/16	15	2	L-1/2	L-3/4	L-1/2	L-1/2
HEL0095*S6A^A	2	3/16	15	2	L-1/2	L-3/4	L-1/2	L-1/2
HEL0105*S6A^A	2	3/16	15	3	L-3/4	L-1	L-3/4	L-3/4
HEL0115*S6A^A	2	3/16	15	4	L-1	L-1-1/2	L-1	L-1
HEL0125*S6A^A	2	3/16	15	4	L-1	L-1-1/2	L-1	L-1
HEL0155*S6A^A	3	3/16	15	4	L-1	L-1-1/2	L-1	L-1
HEL0190*S6A^A	3	3/16	15	6	L-1-1/2	L-2	L-1-1/2	L-1-1/2
HEL0250*S6A^A	4	3/16	15	6	L-1-1/2	L-2	L-1-1/2	L-1-1/2
HEL0295*S6A^A	5	3/16	15	6	L-2	L-2-1/2	L-1-1/2	L-1-1/2
HEL0350*S6A^A	6	3/16	15	7	L-2	L-3	L-2	L-2
HEL0380*S6A^A	6	3/16	15	8	L-2-1/2	L-3	L-2-1/2	L-2-1/2

Notes:

Nozzles sized for 90-100°F liquid temperature at expansion valve.
 Contact Application Engineering for guidance if:
 - Liquid temperature is not 90-100°F
 - Evaporator TD is not 10°-15°F (room temperature – saturated suction temperature)
 Caution: Refrigeration system will not perform properly without correct nozzle

STANDARD NOZZLE SELECTION

Electric Defrost

Low Temperature (-20°F SST)								
Model	No. of Fans	Distributor Tube (in.)		No. of Circuits	Nozzle Selections			
		OD	Length		R-404A/R-507A	R-448A/R-449A	R-407A/R-407F	R-407C
HEL0040*S6E^A	1	3/16	15	2	L-1/2	L-3/4	L-1/2	-
HEL0045*S6E^A	1	3/16	15	2	L-3/4	L-3/4	L-1/2	-
HEL0065*S6E^A	2	3/16	15	3	L-3/4	L-1	L-3/4	-
HEL0080*S6E^A	2	3/16	15	3	L-1	L-1-1/2	L-1	-
HEL0100*S6E^A	2	3/16	15	6	L-1-1/2	L-1-1/2	L-1	-
HEL0130*S6E^A	3	3/16	15	6	L-1-1/2	L-2	L-1-1/2	-
HEL0155*S6E^A	3	3/16	15	8	L-2	L-2-1/2	L-2	-
HEL0170*S6E^A	4	3/16	15	6	L-2	L-2-1/2	L-2	-
HEL0205*S6E^A	4	3/16	15	8	L-2-1/2	L-3	L-2	-
HEL0240*S6E^A	5	3/16	15	8	L-2-1/2	L-4	L-2-1/2	-
HEL0255*S6E^A	6	3/16	15	9	L-3	L-4	L-3	-
HEL0310*S6E^A	6	3/16	15	12	L-4	L-5	L-3	-
HEL0045*S4E^A	1	3/16	15	2	L-1/2	L-3/4	L-1/2	-
HEL0070*S4E^A	2	3/16	15	3	L-3/4	L-1	L-3/4	-
HEL0090*S4E^A	2	3/16	15	6	L-1	L-1-1/2	L-1	-
HEL0135*S4E^A	3	3/16	15	6	L-1-1/2	L-2	L-1-1/2	-
HEL0180*S4E^A	4	3/16	15	8	L-2	L-2-1/2	L-2	-
HEL0220*S4E^A	5	3/16	15	8	L-2	L-3	L-2	-
HEL0275*S4E^A	6	3/16	15	12	L-3	L-4	L-3	-

Medium Temperature (25°F SST)								
Model	No. of Fans	Distributor Tube (in.)		No. of Circuits	Nozzle Selections			
		OD	Length		R-404A/R-507A	R-448A/R-449A	R-407A/R-407F	R-407C
HEL0040*S6E^A	1	3/16	15	2	L-1/4	L-1/3	L-1/4	L-1/4
HEL0045*S6E^A	1	3/16	15	2	L-1/3	L-1/2	L-1/3	L-1/3
HEL0065*S6E^A	2	3/16	15	3	L-1/2	L-3/4	L-1/2	L-1/2
HEL0080*S6E^A	2	3/16	15	3	L-3/4	L-3/4	L-1/2	L-1/2
HEL0100*S6E^A	2	3/16	15	6	L-3/4	L-1	L-3/4	L-3/4
HEL0130*S6E^A	3	3/16	15	6	L-1	L-1-1/2	L-1	L-1
HEL0155*S6E^A	3	3/16	15	8	L-1	L-1-1/2	L-1	L-1
HEL0170*S6E^A	4	3/16	15	6	L-1-1/2	L-1-1/2	L-1-1/2	L-1-1/2
HEL0205*S6E^A	4	3/16	15	8	L-1-1/2	L-2	L-1-1/2	L-1-1/2
HEL0240*S6E^A	5	3/16	15	8	L-1-1/2	L-2	L-1-1/2	L-1-1/2
HEL0255*S6E^A	6	3/16	15	9	L-2	L-2-1/2	L-2	L-2
HEL0310*S6E^A	6	3/16	15	12	L-2	L-3	L-2	L-2
HEL0045*S4E^A	1	3/16	15	2	L-1/3	L-1/2	L-1/4	L-1/4
HEL0070*S4E^A	2	3/16	15	3	L-1/2	L-3/4	L-1/2	L-1/2
HEL0090*S4E^A	2	3/16	15	6	L-3/4	L-3/4	L-3/4	L-3/4
HEL0135*S4E^A	3	3/16	15	6	L-3/4	L-1	L-3/4	L-3/4
HEL0180*S4E^A	4	3/16	15	8	L-1	L-1-1/2	L-1	L-1
HEL0220*S4E^A	5	3/16	15	8	L-1-1/2	L-2	L-1-1/2	L-1-1/2
HEL0275*S4E^A	6	3/16	15	12	L-2	L-2-1/2	L-2	L-2

Notes:
 Nozzles sized for 90-100°F liquid temperature at expansion valve.
 Contact Application Engineering for guidance if:
 - Liquid temperature is not 90-100°F
 - Evaporator TD is not 10°-15°F (room temperature – saturated suction temperature)
 Caution: Refrigeration system will not perform properly without correct nozzle

STANDARD NOZZLE SELECTION

Hot Gas Defrost

Low Temperature (-20°F SST)

Model	No. of Fans	Distributor Tube (in.)		No. of Circuits	Nozzle Selections			
		OD	Length		R-404A/R-507A	R-448A/R-449A	R-407A/R-407F	R-407C
HEL0040*S6H^A	1	3/16	15	2	L-1/2	L-3/4	L-1/2	-
HEL0045*S6H^A	1	3/16	15	2	L-3/4	L-3/4	L-1/2	-
HEL0065*S6H^A	2	3/16	15	3	L-3/4	L-1	L-3/4	-
HEL0080*S6H^A	2	3/16	15	3	L-1	L-1-1/2	L-1	-
HEL0100*S6H^A	2	3/16	15	6	L-1-1/2	L-1-1/2	L-1	-
HEL0130*S6H^A	3	3/16	15	6	L-1-1/2	L-2	L-1-1/2	-
HEL0155*S6H^A	3	3/16	15	8	L-2	L-2-1/2	L-2	-
HEL0170*S6H^A	4	3/16	15	6	L-2	L-2-1/2	L-2	-
HEL0205*S6H^A	4	3/16	15	8	L-2-1/2	L-3	L-2	-
HEL0240*S6H^A	5	3/16	15	8	L-2-1/2	L-4	L-2-1/2	-
HEL0255*S6H^A	6	3/16	15	9	L-3	L-4	L-3	-
HEL0310*S6H^A	6	3/16	15	12	L-4	L-5	L-3	-
HEL0045*S4H^A	1	3/16	15	2	L-1/2	L-3/4	L-1/2	-
HEL0070*S4H^A	2	3/16	15	3	L-3/4	L-1	L-3/4	-
HEL0090*S4H^A	2	3/16	15	6	L-1	L-1-1/2	L-1	-
HEL0135*S4H^A	3	3/16	15	6	L-1-1/2	L-2	L-1-1/2	-
HEL0180*S4H^A	4	3/16	15	8	L-2	L-2-1/2	L-2	-
HEL0220*S4H^A	5	3/16	15	8	L-2	L-3	L-2	-
HEL0275*S4H^A	6	3/16	15	12	L-3	L-4	L-3	-

Medium Temperature (25°F SST)

Model	No. of Fans	Distributor Tube (in.)		No. of Circuits	Nozzle Selections			
		OD	Length		R-404A/R-507A	R-448A/R-449A	R-407A/R-407F	R-407C
HEL0040*S6H^A	1	3/16	15	2	L-1/4	L-1/3	L-1/4	L-1/4
HEL0045*S6H^A	1	3/16	15	2	L-1/3	L-1/2	L-1/3	L-1/3
HEL0065*S6H^A	2	3/16	15	3	L-1/2	L-3/4	L-1/2	L-1/2
HEL0080*S6H^A	2	3/16	15	3	L-3/4	L-3/4	L-1/2	L-1/2
HEL0100*S6H^A	2	3/16	15	6	L-3/4	L-1	L-3/4	L-3/4
HEL0130*S6H^A	3	3/16	15	6	L-1	L-1-1/2	L-1	L-1
HEL0155*S6H^A	3	3/16	15	8	L-1	L-1-1/2	L-1	L-1
HEL0170*S6H^A	4	3/16	15	6	L-1-1/2	L-1-1/2	L-1-1/2	L-1-1/2
HEL0205*S6H^A	4	3/16	15	8	L-1-1/2	L-2	L-1-1/2	L-1-1/2
HEL0240*S6H^A	5	3/16	15	8	L-1-1/2	L-2	L-1-1/2	L-1-1/2
HEL0255*S6H^A	6	3/16	15	9	L-2	L-2-1/2	L-2	L-2
HEL0310*S6H^A	6	3/16	15	12	L-2	L-3	L-2	L-2
HEL0045*S4H^A	1	3/16	15	2	L-1/3	L-1/2	L-1/4	L-1/4
HEL0070*S4H^A	2	3/16	15	3	L-1/2	L-3/4	L-1/2	L-1/2
HEL0090*S4H^A	2	3/16	15	6	L-3/4	L-3/4	L-3/4	L-3/4
HEL0135*S4H^A	3	3/16	15	6	L-3/4	L-1	L-3/4	L-3/4
HEL0180*S4H^A	4	3/16	15	8	L-1	L-1-1/2	L-1	L-1
HEL0220*S4H^A	5	3/16	15	8	L-1-1/2	L-2	L-1-1/2	L-1-1/2
HEL0275*S4H^A	6	3/16	15	12	L-2	L-2-1/2	L-2	L-2

Notes:

Nozzles sized for 90-100°F liquid temperature at expansion valve.
 Contact Application Engineering for guidance if:
 - Liquid temperature is not 90-100°F
 - Evaporator TD is not 10°-15°F (room temperature – saturated suction temperature)
 Caution: Refrigeration system will not perform properly without correct nozzle



2175 West Park Place Blvd.

Stone Mountain, GA 30087

Phone: 800.537.7775 · Fax: 770.465.5900

heatcraftprd.com

Since product improvement is a continuing effort, we reserve the right to make changes in specifications without notice.

CH-LOP-0622 | Version 004

©2022 Heatcraft Refrigeration Products LLC



LK-LOP | JUNE 2022
Replaces January 2022

LOW PROFILE UNIT COOLERS

Technical Guide
Including models meeting DOE minimum AWEF

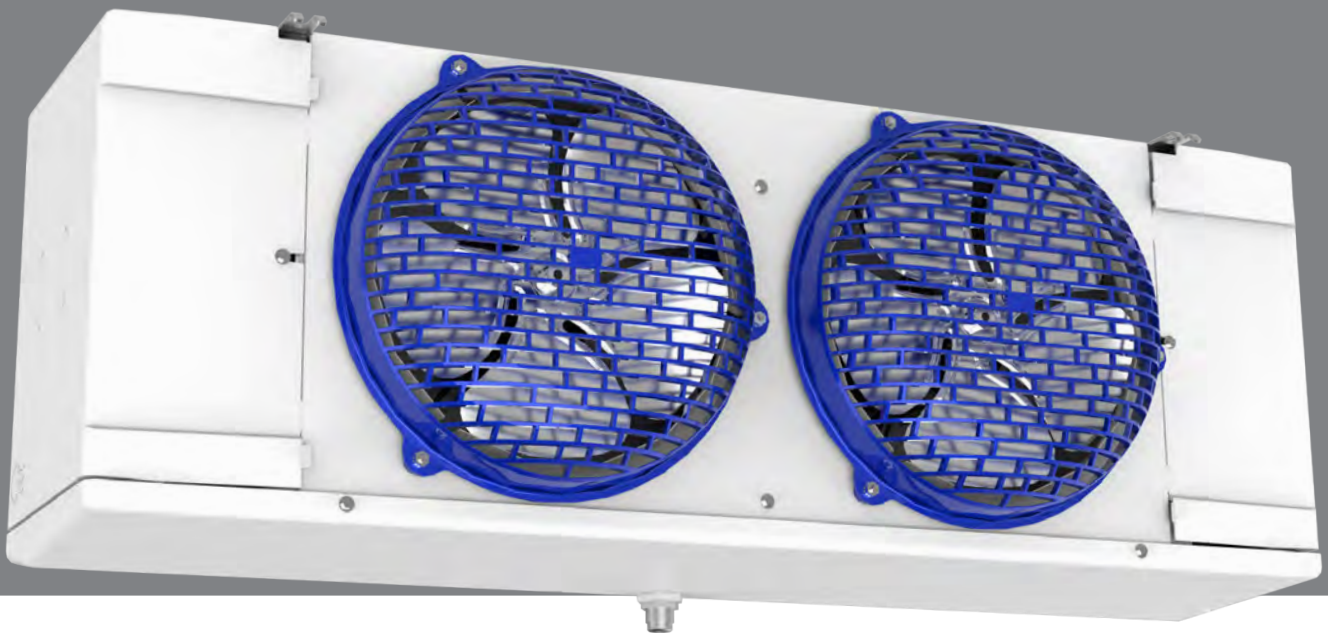
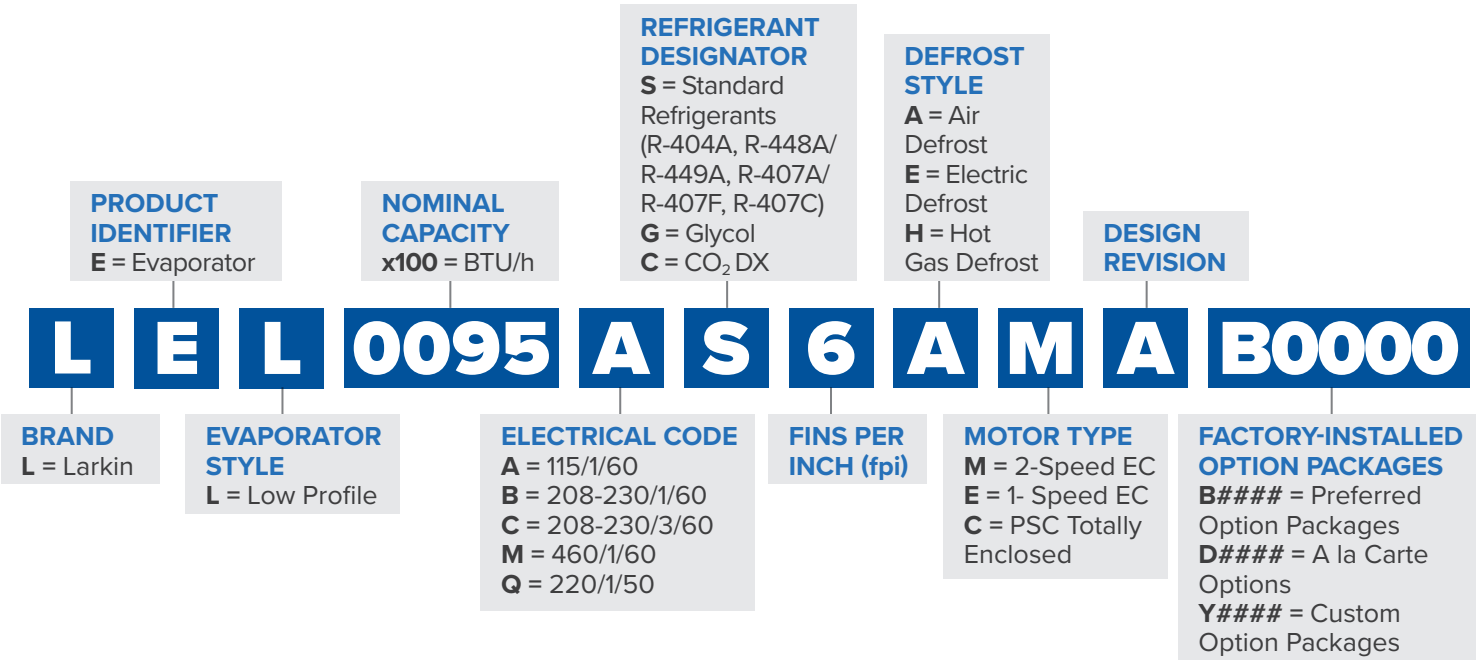


TABLE OF CONTENTS

3	Nomenclature
3	Preferred Option Packages
5	Features & Benefits
7	Air Defrost
7	Performance Data
7	Application Capacity: Air Defrost- 60 Hz
8	Application Capacity: Air Defrost- 60 Hz (CO ₂ DX)
9	Application Capacity: Air Defrost- 50 Hz (For PSC Motors) †
10	Application Capacity: Air Defrost- 50 Hz (CO ₂ DX)
11	Unit Specifications
14	Electric Defrost
14	Performance Data
14	Application Capacity: Low Temperature Electric Defrost- 60 Hz
16	Application Capacity: Low Temperature Electric Defrost- 60 Hz (CO ₂ DX)
17	Application Capacity: Low Temperature Electric Defrost- 50 Hz (For PSC Motors) †
19	Application Capacity: Low Temperature Electric Defrost- 50 Hz (CO ₂ DX)
20	Application Capacity: Medium Temperature Electric Defrost- 60 Hz
22	Application Capacity: Medium Temperature Electric Defrost- 60 Hz (CO ₂ DX)
23	Unit Specifications
	Hot Gas Defrost
27	Performance Data
27	Application Capacity: Low Temperature Hot Gas Defrost- 60 Hz
29	Application Capacity: Low Temperature Hot Gas Defrost- 50 Hz (For PSC Motors) †
31	Application Capacity: Medium Temperature Hot Gas Defrost- 60 Hz
33	Unit Specifications
39	Physical Data
42	Dimensional Drawings
	DOE Rated AWEF
43	AWEF
43	Air Defrost 2-Speed EC Motors
44	Electric Defrost 1-Speed EC Motors
45	Electric Defrost 2-Speed EC Motors
46	Hot Gas Defrost 1-Speed EC Motors
47	Hot Gas Defrost 2-Speed EC Motors
48	Hot Gas Defrost Reverse Cycle
48	Hot Gas Reverse Cycle Kits
48	Reverse Cycle Piping
51	Replacement Parts
51	Motor/Motor Mounts
51	Fan Blade/Fan Guard
51	Cabinet Components
53	Drain Pan Heaters
53	Coil Defrost Heaters
53	Electrical Components
53	Drain Fitting
55	Standard Nozzle Selection
55	Air Defrost
56	Electric Defrost
57	Hot Gas Defrost



NOMENCLATURE



PREFERRED OPTION PACKAGES

(HFC Refrigerants)

Package	Description (standard base model features + indicated options below)
B0000	Standard Base
B0100	Beacon II (R-404A/R-448A/R-449A)
B0101	Beacon II (R-407A/R-407C/R-407F)
B0200	intelliGen Refrigeration Controller (R-404A/R-448A/R-449A)
B0201	intelliGen Refrigeration Controller (R-407A/R-407C/R-407F)
B0300	Quick Response Controller (R-404A/R-448A/R-449A)
B0301	Quick Response Controller (R-407A/R-407C/R-407F)
B0403	Mounted Components (TXV, Solenoid Valve, Electronic T'Stat – R-404A)
B0404	Mounted Components (TXV, Solenoid Valve, Electronic T'Stat – R-407A/C/F)
B0405	Mounted Components (TXV, Solenoid Valve, Electronic T'Stat – R-448A/R-449A)

PREFERRED OPTION PACKAGES

(CO₂ DX)

Package	Description (standard base model features + indicated options below)
B0500 Standard Base	Danfoss EEV (120V) with 1/4" MPT Transducer Connection (Pressure Transducer not included)
B0501	Danfoss EEV (120V) with 1/4" MPT Transducer Connection (Pressure Transducer not included) + Filter Drier
B0502	Sporlan EEV (120V) with 1/4" MPT Transducer Connection (Pressure Transducer not included) + Filter Drier
B0503	Danfoss EEV (120V) with Danfoss Pressure Transducer
B0504	Danfoss EEV (120V) with Danfoss Pressure Transducer + Filter Drier
B0505	Danfoss EEV (120V) with CPC Pressure Transducer
B0506	Danfoss EEV (120V) with CPC Pressure Transducer + Filter Drier
B0507	Sporlan EEV (120V) with Microthermo Pressure Transducer + Filter Drier

FEATURES & BENEFITS

CABINET

- Cabinet design features hinged, removable front access panels on each side for easy access to electrical and refrigeration components.
- Molded fan guard and access panels are made of strong, durable, NSF and UL Sanitation rated lightweight and damage-resistant molded plastic material.
- Quick-removal fan guard/motor assembly for easier servicing of air mover parts.
- Sweat connections to reduce potential for leaks.
- Liquid line solenoid wire harness is factory-installed for quick installation.

COIL

- Internally enhanced tubing and fin design for higher efficiency.
- Coil heater slots have been enlarged for easier installation and replacement.
- Hot gas loop on bottom of coil for easier access is standard on hot gas defrost models.
- Fixed defrost termination for electric, adjustable defrost termination for hot gas.

CONTROLS OPTIONS

- **intelliGen™ Refrigeration Controller (iRC)**
 - Factory mounted, tested and calibrated with an electronic expansion valve, pressure transducer, temperature sensors, control board and User Interface. Standard features include Door Sensor, Product Load Input and Alarm Output.
 - Optional Field installable intelliGen™ Webserver Card (iWC) enables local and remote monitoring on any smart phone, tablet or PC.
 - Optional Field installable intelliGen™ Integration Card (iIC) enables connectivity to BACnet and Modbus.
- **Quick Response Controller** units include factory mounted electronic expansion valve, pressure transducer, temperature sensors and control board.
- **Beacon II™** units include factory mounted electronic expansion valve, pressure transducer, temperature sensors and control board.

MOTORS

- Motors plug into wiring harness for easier servicing.
- 2-Speed EC motors standard on Air Defrost models.
- 1-Speed EC motors standard on Electric Defrost & Hot Gas Defrost models.

DRAIN PAN

- Large diameter drain hole (3/4" ID) is located towards the back of the unit.
- Extended drain pan heaters for more uniform defrost throughout the drain pan and additional heat in end compartments.
- Hinged, removable drain pans allow for easy and safe access (3-6 fan units only).

OTHER OPTIONS

- Units available with factory installed mounted components: Expansion Valve, Mechanical Room Thermostat, Solenoid Valve with Dual Voltage Coil.
- Units available with mounted TXV and mounted TXV with solenoid valve.
 - Pre-assembled units come with mounted TXV, liquid line solenoid valve and room thermostat.
 - Available in a master liquid line configuration.
 - Pre-charged units come with mounted TXV, liquid line solenoid valve, room thermostat and quick connect fittings.
- Units available with stainless steel housing and drain pan.
- All units come standard with aluminum fin, copper tube coils. Units available with various coil material / coating options including polyester fin coating, black electrostatic fin coating, copper fins and Bronz-Glow coil coating. Please review our price book for availability.
- Units available with insulated drain pan.

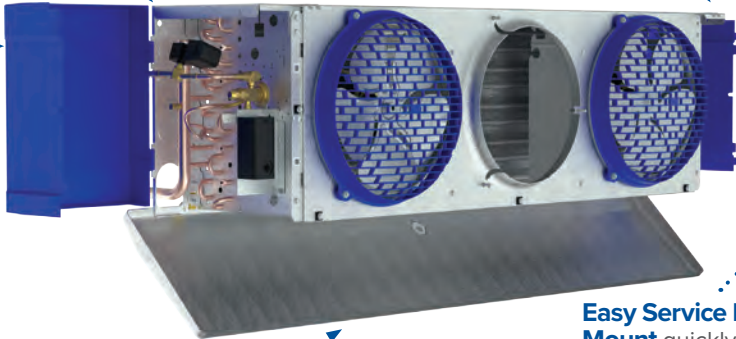
FEATURES & BENEFITS

OUTSTANDING FEATURES

Optional Factory Mounted Components
 Choose from Heatcraft's industry-leading IntelliGen™ Refrigeration Controller, Quick Response Controller, Beacon II Control or traditional mechanical components.

Composite Molded Access Panels have undergone extensive engineering and laboratory testing to ensure they are damage resistant from drops, dents, and bangs.

Hinged & Removeable Access Panels allow for easy access to both refrigeration and electrical end of Low Profile units.



Hinged Drain Pan improves access to service and clean the drain pan and coil. (3-6 fan models only)

Easy Service Motor Mount quickly and easily allows motor to be removed for service or replacement.

Re-Engineered Fan Guards have been redesigned for optimized air circulation and comply to new UL60335 safety standard.

Table 1: Capacity Correction Factors

Electric and Hot Gas Defrost Units				
Saturated Suction Temperature °F	+20	-10	-20	-30
Saturated Suction Temperature °C	-7	-23	-29	-34
Multiply Capacity By	1.15	1.04	1.00	0.90

PERFORMANCE DATA

Application Capacity: Air Defrost- 60 Hz

Please consult AWEF table on page 43 to confirm model meets DOE minimum AWEF

New Model	Legacy Model	R-404A/R-507A		R-448A/R-449A		Fan Data		
		Application Capacity ¹		Application Capacity ¹				
		10°F TD/25°F SST	6°C TD/-4°C SST	10°F TD/25°F SST	6°C TD/-4°C SST	No. of Fans	CFM	m ³ H
		BTUH	Watts	BTUH	Watts			
LEL0045*S6A^A	LCA640	4,000	1,200	4,600	1,300	1	653	1,109
LEL0055*S6A^A	LCA651	5,200	1,500	6,100	1,800	1	610	1,036
LEL0060*S6A^A	LCA662 LCA672	6,500	1,900	7,800	2,300	1	610	1,036
LEL0095*S6A^A	LCA672 LCA690	8,000	2,300	10,000	2,900	2	1,305	2,217
LEL0105*S6A^A	LCA690	9,200	2,650	12,500	3,600	2	1,305	2,217
LEL0115*S6A^A	LCA6110	11,700	3,370	14,500	4,180	2	1,220	2,073
LEL0125*S6A^A	LCA6135	13,000	3,800	15,500	4,500	2	1,220	2,073
LEL0155*S6A^A	LCA6135	14,000	4,100	16,800	4,900	3	1,958	3,327
LEL0190*S6A^A	LCA6160 LCA6185	18,000	5,300	21,200	6,200	3	1,830	3,109
LEL0250*S6A^A	LCA6215	20,800	6,100	24,600	7,200	4	2,440	4,146
LEL0295*S6A^A	LCA6260	26,000	7,600	30,700	9,000	5	3,050	5,182
LEL0350*S6A^A	LCA6310	31,200	9,100	36,800	10,800	6	3,660	6,218
LEL0380*S6A^A	LCA6350	37,000	10,800	44,400	13,000	6	3,660	6,218

New Model	Legacy Model	R-407A/R-407F		R-407C		Fan Data		
		Application Capacity ¹		Application Capacity ¹				
		10°F TD/25°F SST	6°C TD/-4°C SST	10°F TD/25°F SST	6°C TD/-4°C SST	No. of Fans	CFM	m ³ H
		BTUH	Watts	BTUH	Watts			
LEL0045*S6A^A	LCA640	4,600	1,300	4,600	1,300	1	653	1,109
LEL0055*S6A^A	LCA651	6,100	1,800	6,100	1,800	1	610	1,036
LEL0060*S6A^A	LCA662 LCA672	7,800	2,300	7,800	2,300	1	610	1,036
LEL0095*S6A^A	LCA672 LCA690	10,000	2,900	10,000	2,900	2	1,305	2,217
LEL0105*S6A^A	LCA690	12,500	3,600	12,500	3,600	2	1,305	2,217
LEL0115*S6A^A	LCA6110	14,500	4,180	14,500	4,180	2	1,220	2,073
LEL0125*S6A^A	LCA6135	15,500	4,500	15,500	4,500	2	1,220	2,073
LEL0155*S6A^A	LCA6135	16,800	4,900	16,800	4,900	3	1,958	3,327
LEL0190*S6A^A	LCA6160 LCA6185	21,200	6,200	21,200	6,200	3	1,830	3,109
LEL0250*S6A^A	LCA6215	24,600	7,200	24,600	7,200	4	2,440	4,146
LEL0295*S6A^A	LCA6260	30,700	9,000	30,700	9,000	5	3,050	5,182
LEL0350*S6A^A	LCA6310	36,800	10,800	36,800	10,800	6	3,660	6,218
LEL0380*S6A^A	LCA6350	44,400	13,000	44,400	13,000	6	3,660	6,218

Notes:

¹ = Capacities shown are Application Capacities reflecting nominal operation at 10°F TD. For models within the scope of the DOE AWEF (Annual Walk-in Energy Factor) standard, the Net Capacity is determined by the AHRI 1250 test method. DOE will publish this compliance data at www.regulations.doe.gov

* = Electrical Code Designator (see Nomenclature details)

^ = Motor Code Designator (see Nomenclature details)

Net Capacity is available upon request

PERFORMANCE DATA

Application Capacity: Air Defrost- 60 Hz

Please consult AWEF table on page 43 to confirm model meets DOE minimum AWEF

New Model	Legacy Model	CO ₂ DX		Fan Data		
		Application Capacity ¹				
		10°F TD/25°F SST	6°C TD/-4°C SST	No. of Fans	CFM	m ³ H
		BTUH	Watts			
LEL0045*C6A^A	N/A	4,600	1,348	1	653	1,109
LEL0055*C6A^A	N/A	6,100	1,788	1	610	1,036
LEL0060*C6A^A	N/A	7,800	2,286	1	610	1,036
LEL0095*C6A^A	N/A	10,000	2,931	2	1,305	2,217
LEL0105*C6A^A	N/A	12,500	3,663	2	1,305	2,217
LEL0115*C6A^A	N/A	14,500	4,250	2	1,220	2,073
LEL0125*C6A^A	N/A	15,500	4,543	2	1,220	2,073
LEL0155*C6A^A	N/A	16,800	4,924	3	1,958	3,327
LEL0190*C6A^A	N/A	21,200	6,213	3	1,830	3,109
LEL0250*C6A^A	N/A	24,600	7,210	4	2,440	4,146
LEL0295*C6A^A	N/A	30,700	8,997	5	3,050	5,182
LEL0350*C6A^A	N/A	36,800	10,785	6	3,660	6,218
LEL0380*C6A^A	N/A	44,400	13,012	6	3,660	6,218

Notes:
¹ = Capacities shown are Application Capacities reflecting nominal operation at 10°F TD. For models within the scope of the DOE AWEF (Annual Walk-in Energy Factor) standard, the Net Capacity is determined by the AHRI 1250 test method. DOE will publish this compliance data at www.regulations.doe.gov
 * = Electrical Code Designator (see Nomenclature details)
 ^ = Motor Code Designator (see Nomenclature details)
 Net Capacity is available upon request

PERFORMANCE DATA

Application Capacity: Air Defrost- 50 Hz (For PSC Motors)[†]

Please consult AWEF table on page 43 to confirm model meets DOE minimum AWEF

New Model	Legacy Model	R-404A/R-507A		R-448A/R-449A		Fan Data		
		Application Capacity ¹		Application Capacity ¹				
		10°F TD/25°F SST	6°C TD/-4°C SST	10°F TD/25°F SST	6°C TD/-4°C SST	No. of Fans	CFM	m ³ H
		BTUH	Watts	BTUH	Watts			
LEL0045*S6A^A	LCA640	3,800	1,140	4,370	1,235	1	588	999
LEL0055*S6A^A	LCA651	4,940	1,425	5,795	1,710	1	549	933
LEL0060*S6A^A	LCA662 LCA672	6,175	1,805	7,410	2,185	1	549	933
LEL0095*S6A^A	LCA672 LCA690	7,600	2,185	9,500	2,755	2	1,175	1,995
LEL0105*S6A^A	LCA690	8,740	2,518	11,875	3,420	2	1,175	1,995
LEL0115*S6A^A	LCA6110	11,115	3,202	13,775	3,971	2	1,098	1,866
LEL0125*S6A^A	LCA6135 [‡]	12,350	3,610	14,725	4,275	2	1,098	1,866
LEL0155*S6A^A	LCA6135	13,300	3,895	15,960	4,655	3	1,762	2,994
LEL0190*S6A^A	LCA6160 LCA6185 [‡]	17,100	5,035	20,140	5,890	3	1,647	2,798
LEL0250*S6A^A	LCA6215	19,760	5,795	23,370	6,840	4	2,196	3,731
LEL0295*S6A^A	LCA6260	24,700	7,220	29,165	8,550	5	2,745	4,664
LEL0350*S6A^A	LCA6310	29,640	8,645	34,960	10,260	6	3,294	5,597
LEL0380*S6A^A	LCA6350	35,150	10,260	42,180	12,350	6	3,294	5,597

New Model	Legacy Model	R-407A/R-407F		R-407C		Fan Data		
		Application Capacity ¹		Application Capacity ¹				
		10°F TD/25°F SST	6°C TD/-4°C SST	10°F TD/25°F SST	6°C TD/-4°C SST	No. of Fans	CFM	m ³ H
		BTUH	Watts	BTUH	Watts			
LEL0045*S6A^A	LCA640	4,370	1,235	4,370	1,235	1	588	999
LEL0055*S6A^A	LCA651	5,795	1,710	5,795	1,710	1	549	933
LEL0060*S6A^A	LCA662 LCA672	7,410	2,185	7,410	2,185	1	549	933
LEL0095*S6A^A	LCA672 LCA690	9,500	2,755	9,500	2,755	2	1,175	1,995
LEL0105*S6A^A	LCA690	11,875	3,420	11,875	3,420	2	1,175	1,995
LEL0115*S6A^A	LCA6110	13,775	3,971	13,775	3,971	2	1,098	1,866
LEL0125*S6A^A	LCA6135 [‡]	14,725	4,275	14,725	4,275	2	1,098	1,866
LEL0155*S6A^A	LCA6135	15,960	4,655	15,960	4,655	3	1,762	2,994
LEL0190*S6A^A	LCA6160 LCA6185 [‡]	20,140	5,890	20,140	5,890	3	1,647	2,798
LEL0250*S6A^A	LCA6215	23,370	6,840	23,370	6,840	4	2,196	3,731
LEL0295*S6A^A	LCA6260	29,165	8,550	29,165	8,550	5	2,745	4,664
LEL0350*S6A^A	LCA6310	34,960	10,260	34,960	10,260	6	3,294	5,597
LEL0380*S6A^A	LCA6350	42,180	12,350	42,180	12,350	6	3,294	5,597

Notes:

¹ = Capacities shown are Application Capacities reflecting nominal operation at 10°F TD. For models within the scope of the DOE AWEF (Annual Walk-in Energy Factor) standard, the Net Capacity is determined by the AHRI 1250 test method. DOE will publish this compliance data at www.regulations.doe.gov

* = Electrical Code Designator (see Nomenclature details)

^ = Motor Code Designator (see Nomenclature details)

Net Capacity is available upon request

[†] = For 1-speed and 2-speed EC motors, use 60 Hz capacity and airflow values. (units with EC motors operating at 50 Hz will not see a reduction in performance due to the electronic control of the motor)

PERFORMANCE DATA

Application Capacity: Air Defrost- 50 Hz (For PSC Motors) †

Please consult AWEF table on page 43 to confirm model meets DOE minimum AWEF

New Model	Legacy Model	CO ₂ DX		Fan Data		
		Application Capacity ¹				
		10°F TD/25°F SST	6°C TD/-4°C SST	No. of Fans	CFM	m ³ H
		BTUH	Watts			
LEL0045*C6A^A	N/A	4,370	1,281	1	588	999
LEL0055*C6A^A	N/A	5,795	1,698	1	549	933
LEL0060*C6A^A	N/A	7,410	2,172	1	549	933
LEL0095*C6A^A	N/A	9,500	2,784	2	1,175	1,996
LEL0105*C6A^A	N/A	11,875	3,480	2	1,175	1,996
LEL0115*C6A^A	N/A	13,775	4,037	2	1,098	1,866
LEL0125*C6A^A	N/A	14,725	4,315	2	1,098	1,866
LEL0155*C6A^A	N/A	15,960	4,677	3	1,762	2,994
LEL0190*C6A^A	N/A	20,140	5,902	3	1,647	2,798
LEL0250*C6A^A	N/A	23,370	6,849	4	2,196	3,731
LEL0295*C6A^A	N/A	29,165	8,547	5	2,745	4,664
LEL0350*C6A^A	N/A	34,960	10,246	6	3,294	5,597
LEL0380*C6A^A	N/A	42,180	12,362	6	3,294	5,597

Notes:

¹ = Capacities shown are Application Capacities reflecting nominal operation at 10°F TD. For models within the scope of the DOE AWEF (Annual Walk-in Energy Factor) standard, the Net Capacity is determined by the AHRI 1250 test method. DOE will publish this compliance data at www.regulations.doe.gov

* = Electrical Code Designator (see Nomenclature details)

^ = Motor Code Designator (see Nomenclature details)

Net Capacity is available upon request

† = For 1-speed and 2-speed EC motors, use 60 Hz capacity and airflow values. (units with EC motors operating at 50 Hz will not see a reduction in performance due to the electronic control of the motor)

SPECIFICATIONS

Air Defrost- 60 Hz

Please consult AWEF table on page 43 to confirm model meets DOE minimum AWEF

2-Speed EC Motor (Totally Enclosed)									
		115/1/60				208-230/1/60			
New Model	HP	Amps	Watts	MCA	MOPD	Amps	Watts	MCA	MOPD
LEL0045*±6AMA	1/20	0.9	55	1.1	20	0.5	55	0.6	15
LEL0055*±6AMA	1/20	0.9	55	1.1	20	0.5	55	0.6	15
LEL0060*±6AMA	1/20	0.9	55	1.1	20	0.5	55	0.6	15
LEL0095*±6AMA	1/20	1.8	110	2.0	20	1.0	110	1.1	15
LEL0105*±6AMA	1/20	1.8	110	2.0	20	1.0	110	1.1	15
LEL0115*±6AMA	1/20	1.8	110	2.0	20	1.0	110	1.1	15
LEL0125*±6AMA	1/20	1.8	110	2.0	20	1.0	110	1.1	15
LEL0155*±6AMA	1/20	2.7	165	2.9	20	1.5	165	1.6	15
LEL0190*±6AMA	1/20	2.7	165	2.9	20	1.5	165	1.6	15
LEL0250*±6AMA	1/20	3.6	220	3.8	20	2.0	220	2.1	15
LEL0295*±6AMA	1/20	4.5	275	4.7	20	2.5	275	2.6	15
LEL0350*±6AMA	1/20	5.4	330	5.6	20	3.0	330	3.1	15
LEL0380*±6AMA	1/20	5.4	330	5.6	20	3.0	330	3.1	15

1-Speed EC Motor (Totally Enclosed)									
		115/1/60				208-230/1/60			
New Model	HP	Amps	Watts	MCA	MOPD	Amps	Watts	MCA	MOPD
LEL0045*±6AEA	1/20	0.9	55	1.1	20	0.5	59	0.6	15
LEL0055*±6AEA	1/20	0.9	55	1.1	20	0.5	59	0.6	15
LEL0060*±6AEA	1/20	0.9	55	1.1	20	0.5	59	0.6	15
LEL0095*±6AEA	1/20	1.8	110	2.0	20	1.0	118	1.1	15
LEL0105*±6AEA	1/20	1.8	110	2.0	20	1.0	118	1.1	15
LEL0115*±6AEA	1/20	1.8	110	2.0	20	1.0	118	1.1	15
LEL0125*±6AEA	1/20	1.8	110	2.0	20	1.0	118	1.1	15
LEL0155*±6AEA	1/20	2.7	165	2.9	20	1.5	177	1.6	15
LEL0190*±6AEA	1/20	2.7	165	2.9	20	1.5	177	1.6	15
LEL0250*±6AEA	1/20	3.6	220	3.8	20	2.0	236	2.1	15
LEL0295*±6AEA	1/20	4.5	275	4.7	20	2.5	295	2.6	15
LEL0350*±6AEA	1/20	5.4	330	5.6	20	3.0	354	3.1	15
LEL0380*±6AEA	1/20	5.4	330	5.6	20	3.0	354	3.1	15

Notes:

* = Electrical Code Designator (see Nomenclature details)

± = Refrigerant Designator (see Nomenclature details)

SPECIFICATIONS

Air Defrost- 60 Hz

Please consult AWEF table on page 43 to confirm model meets DOE minimum AWEF

New Model	HP	PSC Motor (Totally Enclosed)											
		115/1/60				208-230/1/60				460/1/60			
		Amps	Watts	MCA	MOPD	Amps	Watts	MCA	MOPD	Amps	Watts	MCA	MOPD
LEL0045*±6ACA	1/20	1.0	82	1.3	20	0.5	91	0.6	15	0.4	117	0.5	15
LEL0055*±6ACA	1/20	1.0	82	1.3	20	0.5	91	0.6	15	0.4	117	0.5	15
LEL0060*±6ACA	1/20	1.0	82	1.3	20	0.5	91	0.6	15	0.4	117	0.5	15
LEL0095*±6ACA	1/20	2.0	164	2.3	20	1.0	182	1.1	15	0.8	234	0.9	15
LEL0105*±6ACA	1/20	2.0	164	2.3	20	1.0	182	1.1	15	0.8	234	0.9	15
LEL0115*±6ACA	1/20	2.0	164	2.3	20	1.0	182	1.1	15	0.8	234	0.9	15
LEL0125*±6ACA	1/20	2.0	164	2.3	20	1.0	182	1.1	15	0.8	234	0.9	15
LEL0155*±6ACA	1/20	3.0	246	3.3	20	1.5	273	1.6	15	1.2	351	1.3	15
LEL0190*±6ACA	1/20	3.0	246	3.3	20	1.5	273	1.6	15	1.2	351	1.3	15
LEL0250*±6ACA	1/20	4.0	328	4.3	20	2.0	364	2.1	15	1.6	468	1.7	15
LEL0295*±6ACA	1/20	5.0	410	5.3	20	2.5	455	2.6	15	2.0	585	2.1	15
LEL0350*±6ACA	1/20	6.0	492	6.3	20	3.0	546	3.1	15	2.4	702	2.5	15
LEL0380*±6ACA	1/20	6.0	492	6.3	20	3.0	546	3.1	15	2.4	702	2.5	15

Notes:
 * = Electrical Code Designator (see Nomenclature details)
 ± = Refrigerant Designator (see Nomenclature details)

SPECIFICATIONS

Air Defrost- 50 Hz

Please consult AWEF table on page 43 to confirm model meets DOE minimum AWEF

New Model	HP	2-Speed EC Motor (Totally Enclosed)				1-Speed EC Motor (Totally Enclosed)				PSC Motor (Totally Enclosed)			
		220/1/50				220/1/50				220/1/50			
		Amps	Watts	MCA	MOPD	Amps	Watts	MCA	MOPD	Amps	Watts	MCA	MOPD
LEL0045*±6A^A	1/20	0.5	55	0.6	15	0.5	59	0.6	15	0.5	65	0.6	15
LEL0055*±6A^A	1/20	0.5	55	0.6	15	0.5	59	0.6	15	0.5	65	0.6	15
LEL0060*±6A^A	1/20	0.5	55	0.6	15	0.5	59	0.6	15	0.5	65	0.6	15
LEL0095*±6A^A	1/20	1.0	110	1.1	15	1.0	118	1.1	15	1.0	130	1.1	15
LEL0105*±6A^A	1/20	1.0	110	1.1	15	1.0	118	1.1	15	1.0	130	1.1	15
LEL0115*±6A^A	1/20	1.0	110	1.1	15	1.0	118	1.1	15	1.0	130	1.1	15
LEL0125*±6A^A	1/20	1.0	110	1.1	15	1.0	118	1.1	15	1.0	130	1.1	15
LEL0155*±6A^A	1/20	1.5	165	1.6	15	1.5	177	1.6	15	1.5	195	1.6	15
LEL0190*±6A^A	1/20	1.5	165	1.6	15	1.5	177	1.6	15	1.5	195	1.6	15
LEL0250*±6A^A	1/20	2.0	220	2.1	15	2.0	236	2.1	15	2.0	260	2.1	15
LEL0295*±6A^A	1/20	2.5	275	2.6	15	2.5	295	2.6	15	2.5	325	2.6	15
LEL0350*±6A^A	1/20	3.0	330	3.1	15	3.0	354	3.1	15	3.0	390	3.1	15
LEL0380*±6A^A	1/20	3.0	330	3.1	15	3.0	354	3.1	15	3.0	390	3.1	15

Notes:

* = Electrical Code Designator (see Nomenclature details)

^ = Motor Code Designator (see Nomenclature details)

± = Refrigerant Designator (see Nomenclature details)

PERFORMANCE DATA

Application Capacity: Low Temperature Electric Defrost- 60 Hz

Please consult AWEF table on pages 44 & 45 to confirm model meets DOE minimum AWEF

Please refer to Table 1: Capacity Correction Factors (page 6) if using Saturated Suction Temperatures different than listed in the information below

FPI	New Model	Legacy Model	R-404A/R-507A		R-448A/R-449A		Fan Data		
			Application Capacity ¹		Application Capacity ¹				
			10°F TD/-20°F SST	6°C TD/-29°C SST	10°F TD/-20°F SST	6°C TD/-29°C SST	No. of Fans	CFM	m ³ H
			BTUH	Watts	BTUH	Watts			
6	LEL0040*S6E^A	LCE635	3,500	1,000	3,900	1,000	1	685	1,164
6	LEL0045*S6E^A	LCE643	4,700	1,400	5,300	1,600	1	641	1,088
6	LEL0065*S6E^A	LCE665	6,500	1,900	7,200	2,100	2	1,371	2,329
6	LEL0080*S6E^A	LCE676	7,500	2,200	8,400	2,500	2	1,371	2,329
6	LEL0100*S6E^A	LCE694	9,000	2,600	9,900	2,900	2	1,281	2,176
6	LEL0130*S6E^A	LCE6120	12,000	3,500	13,500	4,000	3	2,056	3,493
6	LEL0155*S6E^A	LCE6140	14,000	4,100	16,000	4,700	3	1,922	3,265
6	LEL0170*S6E^A	LCE6160	16,000	4,700	17,900	5,200	4	2,741	4,658
6	LEL0205*S6E^A	LCE6180	18,000	5,300	20,100	5,900	4	2,562	4,353
6	LEL0240*S6E^A	LCE6200	20,000	5,900	22,800	6,600	5	3,203	5,441
6	LEL0255*S6E^A	LCE6240	24,000	7,000	26,900	7,900	6	4,112	6,986
6	LEL0310*S6E^A	LCE6270	28,000	8,200	31,400	9,200	6	3,843	6,529
4	LEL0045*S4E^A	LCE441	4,100	1,200	4,500	1,300	1	667	1,132
4	LEL0070*S4E^A	LCE457 LCE467	6,800	2,000	7,400	2,200	2	1,425	2,422
4	LEL0090*S4E^A	LCE482	8,000	2,300	8,800	2,600	2	1,332	2,263
4	LEL0135*S4E^A	LCE4105	10,200	3,000	12,800	3,700	3	1,998	3,395
4	LEL0180*S4E^A	LCE4139	13,600	4,000	17,300	5,000	4	2,664	4,527
4	LEL0220*S4E^A	LCE4174	17,000	5,000	19,500	5,600	5	3,331	5,659
4	LEL0275*S4E^A	LCE4208 LCE4235	23,500	6,900	25,900	7,600	6	3,997	6,790

Notes:

¹ = Capacities shown are Application Capacities reflecting nominal operation at 10°F TD. For models within the scope of the DOE AWEF (Annual Walk-in Energy Factor) standard, the Net Capacity is determined by the AHRI 1250 test method. DOE will publish this compliance data at www.regulations.doe.gov

* = Electrical Code Designator (see Nomenclature details)

^ = Motor Code Designator (see Nomenclature details)

Net Capacity is available upon request

PERFORMANCE DATA

Application Capacity: Low Temperature Electric Defrost- 60 Hz

Please consult AWEF table on pages 44 & 45 to confirm model meets DOE minimum AWEF

Please refer to Table 1: Capacity Correction Factors (page 6) if using Saturated Suction Temperatures different than listed in the information below

FPI	New Model	Legacy Model	R-407A/R-407F		R-407C		Fan Data		
			Application Capacity ¹		Application Capacity ¹				
			10°F TD/-20°F SST	6°C TD/-29°C SST	10°F TD/-20°F SST	6°C TD/-29°C SST	No. of Fans	CFM	m ³ H
			BTUH	Watts	BTUH	Watts			
6	LEL0040*S6E^A	LCE635	3,900	1,000	-	-	1	685	1,164
6	LEL0045*S6E^A	LCE643	5,300	1,600	-	-	1	641	1,088
6	LEL0065*S6E^A	LCE665	7,200	2,100	-	-	2	1,371	2,329
6	LEL0080*S6E^A	LCE676	8,400	2,500	-	-	2	1,371	2,329
6	LEL0100*S6E^A	LCE694	9,900	2,900	-	-	2	1,281	2,176
6	LEL0130*S6E^A	LCE6120	13,500	4,000	-	-	3	2,056	3,493
6	LEL0155*S6E^A	LCE6140	16,000	4,700	-	-	3	1,922	3,265
6	LEL0170*S6E^A	LCE6160	17,900	5,200	-	-	4	2,741	4,658
6	LEL0205*S6E^A	LCE6180	20,100	5,900	-	-	4	2,562	4,353
6	LEL0240*S6E^A	LCE6200	22,400	6,500	-	-	5	3,203	5,441
6	LEL0255*S6E^A	LCE6240	26,900	7,900	-	-	6	4,112	6,986
6	LEL0310*S6E^A	LCE6270	31,400	9,200	-	-	6	3,843	6,529
4	LEL0045*S4E^A	LCE441	4,500	1,300	-	-	1	667	1,132
4	LEL0070*S4E^A	LCE457 LCE467	7,400	2,200	-	-	2	1,425	2,422
4	LEL0090*S4E^A	LCE482	8,800	2,600	-	-	2	1,332	2,263
4	LEL0135*S4E^A	LCE4105	12,100	3,500	-	-	3	1,998	3,395
4	LEL0180*S4E^A	LCE4139	16,300	4,700	-	-	4	2,664	4,527
4	LEL0220*S4E^A	LCE4174	19,600	5,600	-	-	5	3,331	5,659
4	LEL0275*S4E^A	LCE4208 LCE4235	25,900	7,600	-	-	6	3,997	6,790

Notes:

¹ = Capacities shown are Application Capacities reflecting nominal operation at 10°F TD. For models within the scope of the DOE AWEF (Annual Walk-in Energy Factor) standard, the Net Capacity is determined by the AHRI 1250 test method. DOE will publish this compliance data at www.regulations.doe.gov

* = Electrical Code Designator (see Nomenclature details)

^ = Motor Code Designator (see Nomenclature details)

Net Capacity is available upon request

PERFORMANCE DATA

Application Capacity: Low Temperature Electric Defrost- 60 Hz

Please consult AWEF table on pages 44 & 45 to confirm model meets DOE minimum AWEF

Please refer to Table 1: Capacity Correction Factors (page 6) if using Saturated Suction Temperatures different than listed in the information below

FPI	New Model	Legacy Model	CO ₂ DX		Fan Data		
			Application Capacity ¹				
			10°F TD/-20°F SST	6°C TD/-29°C SST	No. of Fans	CFM	m ³ H
			BTUH	Watts			
6	LEL0040*C6E^A	N/A	3,900	1,143	1	685	1,164
6	LEL0045*C6E^A	N/A	5,300	1,553	1	641	1,088
6	LEL0065*C6E^A	N/A	7,200	2,110	2	1,371	2,329
6	LEL0080*C6E^A	N/A	8,400	2,462	2	1,371	2,329
6	LEL0100*C6E^A	N/A	9,900	2,901	2	1,281	2,176
6	LEL0130*C6E^A	N/A	13,500	3,956	3	2,056	3,493
6	LEL0155*C6E^A	N/A	16,000	4,689	3	1,922	3,265
6	LEL0170*C6E^A	N/A	17,900	5,246	4	2,741	4,657
6	LEL0205*C6E^A	N/A	20,100	5,891	4	2,562	4,353
6	LEL0240*C6E^A	N/A	22,400	6,565	5	3,203	5,441
6	LEL0255*C6E^A	N/A	26,900	7,884	6	4,112	6,986
6	LEL0310*C6E^A	N/A	31,400	9,202	6	3,843	6,529
4	LEL0045*C4E^A	N/A	4,500	1,319	1	667	1,132
4	LEL0070*C4E^A	N/A	7,400	2,169	2	1,425	2,422
4	LEL0090*C4E^A	N/A	8,800	2,579	2	1,332	2,263
4	LEL0135*C4E^A	N/A	12,100	3,546	3	1,998	3,395
4	LEL0180*C4E^A	N/A	16,300	4,777	4	2,664	4,527
4	LEL0220*C4E^A	N/A	19,600	5,744	5	3,331	5,659
4	LEL0275*C4E^A	N/A	25,900	7,591	6	3,997	6,790

Notes:
¹ = Capacities shown are Application Capacities reflecting nominal operation at 10°F TD. For models within the scope of the DOE AWEF (Annual Walk-in Energy Factor) standard, the Net Capacity is determined by the AHRI 1250 test method. DOE will publish this compliance data at www.regulations.doe.gov
 * = Electrical Code Designator (see Nomenclature details)
 ^ = Motor Code Designator (see Nomenclature details)
 Net Capacity is available upon request

PERFORMANCE DATA

Application Capacity: Low Temperature Electric Defrost- 50 Hz (For PSC Motors)[†]

Please consult AWEF table on pages 44 & 45 to confirm model meets DOE minimum AWEF

Please refer to Table 1: Capacity Correction Factors (page 6) if using Saturated Suction Temperatures different than listed in the information below

FPI	New Model	Legacy Model	R-404A/R-507A		R-448A/R-449A		Fan Data		
			Application Capacity ¹		Application Capacity ¹				
			10°F TD/-20°F SST	6°C TD/-29°C SST	10°F TD/-20°F SST	6°C TD/-29°C SST	No. of Fans	CFM	m ³ H
			BTUH	Watts	BTUH	Watts			
6	LEL0040*S6E^A	LCE635	3,325	950	3,705	950	1	617	1,048
6	LEL0045*S6E^A	LCE643	4,465	1,330	5,035	1,520	1	576	979
6	LEL0065*S6E^A	LCE665	6,175	1,805	6,840	1,995	2	1,234	2,096
6	LEL0080*S6E^A	LCE676	7,125	2,090	7,980	2,375	2	1,234	2,096
6	LEL0100*S6E^A	LCE694	8,550	2,470	9,405	2,755	2	1,153	1,959
6	LEL0130*S6E^A	LCE6120	11,400	3,325	12,825	3,800	3	1,850	3,144
6	LEL0155*S6E^A	LCE6140	13,300	3,895	15,200	4,465	3	1,729	2,938
6	LEL0170*S6E^A	LCE6160	15,200	4,465	17,005	4,940	4	2,467	4,192
6	LEL0205*S6E^A	LCE6180	17,100	5,035	19,095	5,605	4	2,306	3,918
6	LEL0240*S6E^A	LCE6200	19,000	5,605	21,660	6,270	5	2,882	4,897
6	LEL0255*S6E^A	LCE6240	22,800	6,650	25,555	7,505	6	3,701	6,288
6	LEL0310*S6E^A	LCE6270	26,600	7,790	29,830	8,740	6	2,459	5,876
4	LEL0045*S4E^A	LCE441	3,895	1,140	4,275	1,235	1	600	1,019
4	LEL0070*S4E^A	LCE457 LCE467	6,460	1,900	7,030	2,090	2	1,283	2,180
4	LEL0090*S4E^A	LCE482	7,600	2,185	8,360	2,470	2	1,199	2,037
4	LEL0135*S4E^A	LCE4105	9,690	2,850	12,160	3,515	3	1,799	3,056
4	LEL0180*S4E^A	LCE4139	12,920	3,800	16,435	4,750	4	2,398	4,074
4	LEL0220*S4E^A	LCE4174	16,150	4,750	18,525	5,320	5	2,998	5,093
4	LEL0275*S4E^A	LCE4208 LCE4235	22,325	6,555	24,605	7,220	6	3,597	6,111

Notes:

¹ = Capacities shown are Application Capacities reflecting nominal operation at 10°F TD. For models within the scope of the DOE AWEF (Annual Walk-in Energy Factor) standard, the Net Capacity is determined by the AHRI 1250 test method. DOE will publish this compliance data at www.regulations.doe.gov

* = Electrical Code Designator (see Nomenclature details)

^ = Motor Code Designator (see Nomenclature details)

Net Capacity is available upon request

[†] = For 1-speed and 2-speed EC motors, use 60 Hz capacity and airflow values. (units with EC motors operating at 50 Hz will not see a reduction in performance due to the electronic control of the motor)

PERFORMANCE DATA

Application Capacity: Low Temperature Electric Defrost- 50 Hz (For PSC Motors)[†]

Please consult AWEF table on pages 44 & 45 to confirm model meets DOE minimum AWEF

Please refer to Table 1: Capacity Correction Factors (page 6) if using Saturated Suction Temperatures different than listed in the information below

FPI	New Model	Legacy Model	R-407A/R-407F		R-407C		Fan Data		
			Application Capacity ¹		Application Capacity ¹				
			10°F TD/-20°F SST	6°C TD/-29°C SST	10°F TD/-20°F SST	6°C TD/-29°C SST	No. of Fans	CFM	m ³ H
			BTUH	Watts	BTUH	Watts			
6	LEL0040*S6E^A	LCE635	3,705	950	-	-	1	617	1,048
6	LEL0045*S6E^A	LCE643	5,035	1,520	-	-	1	576	979
6	LEL0065*S6E^A	LCE665	6,840	1,995	-	-	2	1,234	2,096
6	LEL0080*S6E^A	LCE676	7,980	2,375	-	-	2	1,234	2,096
6	LEL0100*S6E^A	LCE694	9,405	2,755	-	-	2	1,153	1,959
6	LEL0130*S6E^A	LCE6120	12,825	3,800	-	-	3	1,850	3,144
6	LEL0155*S6E^A	LCE6140	15,200	4,465	-	-	3	1,729	2,938
6	LEL0170*S6E^A	LCE6160	17,005	4,940	-	-	4	2,467	4,192
6	LEL0205*S6E^A	LCE6180	19,095	5,605	-	-	4	2,306	3,918
6	LEL0240*S6E^A	LCE6200	21,280	6,175	-	-	5	2,882	4,897
6	LEL0255*S6E^A	LCE6240	25,555	7,505	-	-	6	3,701	6,288
6	LEL0310*S6E^A	LCE6270	29,830	8,740	-	-	6	2,459	5,876
4	LEL0045*S4E^A	LCE441	4,275	1,235	-	-	1	600	1,019
4	LEL0070*S4E^A	LCE457 LCE467	7,030	2,090	-	-	2	1,283	2,180
4	LEL0090*S4E^A	LCE482	8,360	2,470	-	-	2	1,199	2,037
4	LEL0135*S4E^A	LCE4105	11,495	3,325	-	-	3	1,799	3,056
4	LEL0180*S4E^A	LCE4139	15,485	4,465	-	-	4	2,398	4,074
4	LEL0220*S4E^A	LCE4174	18,620	5,320	-	-	5	2,998	5,093
4	LEL0275*S4E^A	LCE4208 LCE4235	24,605	7,220	-	-	6	3,597	6,111

Notes:

¹ = Capacities shown are Application Capacities reflecting nominal operation at 10°F TD. For models within the scope of the DOE AWEF (Annual Walk-in Energy Factor) standard, the Net Capacity is determined by the AHRI 1250 test method. DOE will publish this compliance data at www.regulations.doe.gov

* = Electrical Code Designator (see Nomenclature details)

^ = Motor Code Designator (see Nomenclature details)

Net Capacity is available upon request

[†] = For 1-speed and 2-speed EC motors, use 60 Hz capacity and airflow values. (units with EC motors operating at 50 Hz will not see a reduction in performance due to the electronic control of the motor)

PERFORMANCE DATA

Application Capacity: Low Temperature Electric Defrost- 50 Hz (For PSC Motors) †

Please consult AWEF table on pages 44 & 45 to confirm model meets DOE minimum AWEF

Please refer to Table 1: Capacity Correction Factors (page 6) if using Saturated Suction Temperatures different than listed in the information below

FPI	New Model	Legacy Model	CO ₂ DX		Fan Data		
			Application Capacity ¹		No. of Fans	CFM	m ³ H
			10°F TD/-20°F SST	6°C TD/-29°C SST			
			BTUH	Watts			
6	LEL0040*C6E^A	N/A	3,705	1,086	1	617	1,048
6	LEL0045*C6E^A	N/A	5,035	1,476	1	576	979
6	LEL0065*C6E^A	N/A	6,840	2,005	2	1,234	2,096
6	LEL0080*C6E^A	N/A	7,980	2,339	2	1,234	2,096
6	LEL0100*C6E^A	N/A	9,405	2,756	2	1,153	1,959
6	LEL0130*C6E^A	N/A	12,825	3,759	3	1,850	3,144
6	LEL0155*C6E^A	N/A	15,200	4,455	3	1,729	2,938
6	LEL0170*C6E^A	N/A	17,005	4,984	4	2,467	4,192
6	LEL0205*C6E^A	N/A	19,095	5,596	4	2,306	3,918
6	LEL0240*C6E^A	N/A	21,280	6,237	5	2,882	4,897
6	LEL0255*C6E^A	N/A	25,555	7,489	6	3,701	6,288
6	LEL0310*C6E^A	N/A	29,830	8,742	6	2,459	5,876
4	LEL0045*C4E^A	N/A	4,275	1,253	1	600	1,019
4	LEL0070*C4E^A	N/A	7,030	2,060	2	1,283	2,180
4	LEL0090*C4E^A	N/A	8,360	2,450	2	1,199	2,037
4	LEL0135*C4E^A	N/A	11,495	3,369	3	1,799	3,056
4	LEL0180*C4E^A	N/A	15,485	4,538	4	2,398	4,074
4	LEL0220*C4E^A	N/A	18,620	5,457	5	2,998	5,093
4	LEL0275*C4E^A	N/A	24,605	7,211	6	3,597	6,111

Notes:

¹ = Capacities shown are Application Capacities reflecting nominal operation at 10°F TD. For models within the scope of the DOE AWEF (Annual Walk-in Energy Factor) standard, the Net Capacity is determined by the AHRI 1250 test method. DOE will publish this compliance data at www.regulations.doe.gov

* = Electrical Code Designator (see Nomenclature details)

^ = Motor Code Designator (see Nomenclature details)

Net Capacity is available upon request

† = For 1-speed and 2-speed EC motors, use 60 Hz capacity and airflow values. (units with EC motors operating at 50 Hz will not see a reduction in performance due to the electronic control of the motor)

PERFORMANCE DATA

Application Capacity: Medium Temperature Electric Defrost- 60 Hz

Please consult AWEF table on pages 44 & 45 to confirm model meets DOE minimum AWEF

Please refer to Table 1: Capacity Correction Factors (page 6) if using Saturated Suction Temperatures different than listed in the information below

FPI	New Model	Legacy Model	R-404A/R-507A		R-448A/R-449A		Fan Data		
			Application Capacity ¹		Application Capacity ¹				
			10°F TD/-20°F SST	6°C TD/-4°C SST	10°F TD/-20°F SST	6°C TD/-4°C SST	No. of Fans	CFM	m ³ H
			BTUH	Watts	BTUH	Watts			
6	LEL0040*S6E^A	LCE635	4,000	1,200	4,500	1,300	1	685	1,164
6	LEL0045*S6E^A	LCE643	5,400	1,550	6,100	1,750	1	641	1,088
6	LEL0065*S6E^A	LCE665	7,450	2,150	8,300	2,400	2	1,371	2,329
6	LEL0080*S6E^A	LCE676	8,650	2,500	9,650	2,800	2	1,371	2,329
6	LEL0100*S6E^A	LCE694	10,350	3,000	11,400	3,300	2	1,281	2,176
6	LEL0130*S6E^A	LCE6120	13,800	4,000	15,500	4,500	3	2,056	3,493
6	LEL0155*S6E^A	LCE6140	16,100	4,650	18,400	5,300	3	1,922	3,265
6	LEL0170*S6E^A	LCE6160	18,400	5,300	20,600	5,950	4	2,741	4,658
6	LEL0205*S6E^A	LCE6180	20,700	6,000	23,100	6,650	4	2,562	4,353
6	LEL0240*S6E^A	LCE6200	23,000	6,650	25,750	7,450	5	3,203	5,441
6	LEL0255*S6E^A	LCE6240	27,600	7,950	30,950	8,950	6	4,112	6,986
6	LEL0310*S6E^A	LCE6270	32,200	9,300	36,100	10,400	6	3,843	6,529
4	LEL0045*S4E^A	LCE441	4,700	1,400	5,200	1,500	1	667	1,132
4	LEL0070*S4E^A	LCE457 LCE467	7,800	2,250	8,500	2,450	2	1,425	2,422
4	LEL0090*S4E^A	LCE482	9,200	2,650	10,100	2,900	2	1,332	2,263
4	LEL0135*S4E^A	LCE4105	11,750	3,400	13,050	3,800	3	1,998	3,395
4	LEL0180*S4E^A	LCE4139	15,650	4,500	17,650	5,100	4	2,664	4,527
4	LEL0220*S4E^A	LCE4174	19,550	5,650	21,850	6,300	5	3,331	5,659
4	LEL0275*S4E^A	LCE4208 LCE4235	27,000	7,800	29,800	8,600	6	3,997	6,790

Notes:
¹ = Capacities shown are Application Capacities reflecting nominal operation at 10°F TD. For models within the scope of the DOE AWEF (Annual Walk-in Energy Factor) standard, the Net Capacity is determined by the AHRI 1250 test method. DOE will publish this compliance data at www.regulations.doe.gov
 * = Electrical Code Designator (see Nomenclature details)
 ^ = Motor Code Designator (see Nomenclature details)
 Net Capacity is available upon request

PERFORMANCE DATA

Application Capacity: Medium Temperature Electric Defrost- 60 Hz

Please consult AWEF table on pages 44 & 45 to confirm model meets DOE minimum AWEF

Please refer to Table 1: Capacity Correction Factors (page 6) if using Saturated Suction Temperatures different than listed in the information below

FPI	New Model	Legacy Model	R-407A/R-407F		R-407C		Fan Data		
			Application Capacity ¹		Application Capacity ¹				
			10°F TD/-20°F SST	6°C TD/-4°C SST	10°F TD/-20°F SST	6°C TD/-4°C SST	No. of Fans	CFM	m ³ H
			BTUH	Watts	BTUH	Watts			
6	LEL0040*S6E^A	LCE635	4,500	1,300	-	-	1	685	1,164
6	LEL0045*S6E^A	LCE643	6,100	1,750	-	-	1	641	1,088
6	LEL0065*S6E^A	LCE665	8,300	2,400	-	-	2	1,371	2,329
6	LEL0080*S6E^A	LCE676	9,650	2,800	-	-	2	1,371	2,329
6	LEL0100*S6E^A	LCE694	11,400	3,300	-	-	2	1,281	2,176
6	LEL0130*S6E^A	LCE6120	15,500	4,500	-	-	3	2,056	3,493
6	LEL0155*S6E^A	LCE6140	18,400	5,300	-	-	3	1,922	3,265
6	LEL0170*S6E^A	LCE6160	20,600	5,950	-	-	4	2,741	4,658
6	LEL0205*S6E^A	LCE6180	23,100	6,650	-	-	4	2,562	4,353
6	LEL0240*S6E^A	LCE6200	25,750	7,450	-	-	5	3,203	5,441
6	LEL0255*S6E^A	LCE6240	30,950	8,950	-	-	6	4,112	6,986
6	LEL0310*S6E^A	LCE6270	36,100	10,400	-	-	6	3,843	6,529
4	LEL0045*S4E^A	LCE441	5,200	1,500	-	-	1	667	1,132
4	LEL0070*S4E^A	LCE457 LCE467	8,500	2,450	-	-	2	1,425	2,422
4	LEL0090*S4E^A	LCE482	10,100	2,900	-	-	2	1,332	2,263
4	LEL0135*S4E^A	LCE4105	13,050	3,800	-	-	3	1,998	3,395
4	LEL0180*S4E^A	LCE4139	17,650	5,100	-	-	4	2,664	4,527
4	LEL0220*S4E^A	LCE4174	21,850	6,300	-	-	5	3,331	5,659
4	LEL0275*S4E^A	LCE4208 LCE4235	29,800	8,600	-	-	6	3,997	6,790

Notes:

¹ = Capacities shown are Application Capacities reflecting nominal operation at 10°F TD. For models within the scope of the DOE AWEF (Annual Walk-in Energy Factor) standard, the Net Capacity is determined by the AHRI 1250 test method. DOE will publish this compliance data at www.regulations.doe.gov

* = Electrical Code Designator (see Nomenclature details)

^ = Motor Code Designator (see Nomenclature details)

Net Capacity is available upon request

PERFORMANCE DATA

Application Capacity: Medium Temperature Electric Defrost- 60 Hz

Please consult AWEF table on pages 44 & 45 to confirm model meets DOE minimum AWEF

Please refer to Table 1: Capacity Correction Factors (page 6) if using Saturated Suction Temperatures different than listed in the information below

FPI	New Model	Legacy Model	CO ₂ DX		Fan Data		
			Application Capacity ¹		No. of Fans	CFM	m ³ H
			10°F TD/-20°F SST	6°C TD/-29°C SST			
			BTUH	Watts			
6	LEL0040*C6E^A	N/A	4,500	1,319	1	685	1,164
6	LEL0045*C6E^A	N/A	6,100	1,788	1	641	1,089
6	LEL0065*C6E^A	N/A	8,300	2,432	2	1,371	2,329
6	LEL0080*C6E^A	N/A	9,650	2,828	2	1,371	2,329
6	LEL0100*C6E^A	N/A	11,400	3,341	2	1,281	2,176
6	LEL0130*C6E^A	N/A	15,500	4,543	3	2,056	3,493
6	LEL0155*C6E^A	N/A	18,400	5,393	3	1,922	3,265
6	LEL0170*C6E^A	N/A	20,600	6,037	4	2,741	4,657
6	LEL0205*C6E^A	N/A	23,100	6,770	4	2,562	4,353
6	LEL0240*C6E^A	N/A	25,750	7,547	5	3,203	5,442
6	LEL0255*C6E^A	N/A	30,950	9,071	6	4,112	6,986
6	LEL0310*C6E^A	N/A	36,100	10,580	6	3,843	6,529
4	LEL0045*C4E^A	N/A	5,200	1,524	1	641	1,089
4	LEL0070*C4E^A	N/A	8,500	2,491	2	1,425	2,421
4	LEL0090*C4E^A	N/A	10,100	2,960	2	1,332	2,263
4	LEL0135*C4E^A	N/A	13,050	3,825	3	1,998	3,395
4	LEL0180*C4E^A	N/A	17,650	5,173	4	2,664	4,526
4	LEL0220*C4E^A	N/A	21,850	6,404	5	3,331	5,659
4	LEL0275*C4E^A	N/A	29,800	8,734	6	3,997	6,791

Notes:
¹ = Capacities shown are Application Capacities reflecting nominal operation at 10°F TD. For models within the scope of the DOE AWEF (Annual Walk-in Energy Factor) standard, the Net Capacity is determined by the AHRI 1250 test method. DOE will publish this compliance data at www.regulations.doe.gov
 * = Electrical Code Designator (see Nomenclature details)
 ^ = Motor Code Designator (see Nomenclature details)
 Net Capacity is available upon request

SPECIFICATIONS

Electric Defrost- 60 Hz

Please consult AWEF table on pages 44 & 45 to confirm model meets DOE minimum AWEF

FPI	New Model	HP	2-Speed EC Motor (Totally Enclosed)				Defrost Heaters-230V			Defrost Heaters-460V	
			208-230/1/60				Watts	230/1/60	230/3/60	Watts	460/1/60
			Amps	Watts	MCA	MOPD					
6	LEL0040*±6EMA	1/20	0.5	55	0.6	15	1,050	4.6	2.8	900	2.0
6	LEL0045*±6EMA	1/20	0.5	55	0.6	15	1,050	4.6	2.8	900	2.0
6	LEL0065*±6EMA	1/20	1.0	110	1.1	15	2,100	9.1	5.7	1,800	3.9
6	LEL0080*±6EMA	1/20	1.0	110	1.1	15	2,100	9.1	5.7	1,800	3.9
6	LEL0100*±6EMA	1/20	1.0	110	1.1	15	2,100	9.1	5.7	1,800	3.9
6	LEL0130*±6EMA	1/20	1.5	165	1.6	15	3,150	13.7	8.5	2,700	5.9
6	LEL0155*±6EMA	1/20	1.5	165	1.6	15	3,150	13.7	8.5	2,700	5.9
6	LEL0170*±6EMA	1/20	2.0	220	2.1	15	4,200	18.3	11.4	3,600	7.8
6	LEL0205*±6EMA	1/20	2.0	220	2.1	15	4,200	18.3	11.4	3,600	7.8
6	LEL0240*±6EMA	1/20	2.5	275	2.6	15	5,250	22.8	14.2	4,500	9.8
6	LEL0255*±6EMA	1/20	3.0	330	3.1	15	6,300	27.4	17.1	5,400	11.7
6	LEL0310*±6EMA	1/20	3.0	330	3.1	15	6,300	27.4	17.1	5,400	11.7
4	LEL0045*±4EMA	1/20	0.5	55	0.6	15	1,050	4.6	2.8	900	2.0
4	LEL0070*±4EMA	1/20	1.0	110	1.1	15	2,100	9.1	5.7	1,800	3.9
4	LEL0090*±4EMA	1/20	1.0	110	1.1	15	2,100	9.1	5.7	1,800	3.9
4	LEL0135*±4EMA	1/20	1.5	165	1.6	15	3,150	13.7	8.5	2,700	5.9
4	LEL0180*±4EMA	1/20	2.0	220	2.1	15	4,200	18.3	11.4	3,600	7.8
4	LEL0220*±4EMA	1/20	2.5	275	2.6	15	5,250	22.8	14.2	4,500	9.8
4	LEL0275*±4EMA	1/20	3.0	330	3.1	15	6,300	27.4	17.1	5,400	11.7

FPI	New Model	HP	1-Speed EC Motor (Totally Enclosed)				Defrost Heaters-230V			Defrost Heaters-460V	
			208-230/1/60				Watts	230/1/60	230/3/60	Watts	460/1/60
			Amps	Watts	MCA	MOPD					
6	LEL0040*±6EEA	1/20	0.5	59	0.6	15	1,050	4.6	2.8	900	2.0
6	LEL0045*±6EEA	1/20	0.5	59	0.6	15	1,050	4.6	2.8	900	2.0
6	LEL0065*±6EEA	1/20	1.0	118	1.1	15	2,100	9.1	5.7	1,800	3.9
6	LEL0080*±6EEA	1/20	1.0	118	1.1	15	2,100	9.1	5.7	1,800	3.9
6	LEL0100*±6EEA	1/20	1.0	118	1.1	15	2,100	9.1	5.7	1,800	3.9
6	LEL0130*±6EEA	1/20	1.5	177	1.6	15	3,150	13.7	8.5	2,700	5.9
6	LEL0155*±6EEA	1/20	1.5	177	1.6	15	3,150	13.7	8.5	2,700	5.9
6	LEL0170*±6EEA	1/20	2.0	236	2.1	15	4,200	18.3	11.4	3,600	7.8
6	LEL0205*±6EEA	1/20	2.0	236	2.1	15	4,200	18.3	11.4	3,600	7.8
6	LEL0240*±6EEA	1/20	2.5	295	2.6	15	5,250	22.8	14.2	4,500	9.8
6	LEL0255*±6EEA	1/20	3.0	354	3.1	15	6,300	27.4	17.1	5,400	11.7
6	LEL0310*±6EEA	1/20	3.0	354	3.1	15	6,300	27.4	17.1	5,400	11.7
4	LEL0045*±4EEA	1/20	0.5	59	0.6	15	1,050	4.6	2.8	900	2.0
4	LEL0070*±4EEA	1/20	1.0	118	1.1	15	2,100	9.1	5.7	1,800	3.9
4	LEL0090*±4EEA	1/20	1.0	118	1.1	15	2,100	9.1	5.7	1,800	3.9
4	LEL0135*±4EEA	1/20	1.5	177	1.6	15	3,150	13.7	8.5	2,700	5.9
4	LEL0180*±4EEA	1/20	2.0	236	2.1	15	4,200	18.3	11.4	3,600	7.8
4	LEL0220*±4EEA	1/20	2.5	295	2.6	15	5,250	22.8	14.2	4,500	9.8
4	LEL0275*±4EEA	1/20	3.0	354	3.1	15	6,300	27.4	17.1	5,400	11.7

Notes:

* = Electrical Code Designator (see Nomenclature details)

± = Refrigerant Designator (see Nomenclature details)

SPECIFICATIONS

Electric Defrost- 60 Hz

Please consult AWEF table on pages 44 & 45 to confirm model meets DOE minimum AWEF

FPI	New Model	HP	PSC Motor (Totally Enclosed)				Defrost Heaters-230V			Defrost Heaters-460V	
			208-230/1/60				Watts	230/1/60	230/3/60	Watts	460/1/60
			Amps	Watts	MCA	MOPD					
6	LEL0040*±6ECA	1/20	0.5	91	0.6	15	1,050	4.6	2.8	900	2.0
6	LEL0045*±6ECA	1/20	0.5	91	0.6	15	1,050	4.6	2.8	900	2.0
6	LEL0065*±6ECA	1/20	1.0	182	1.1	15	2,100	9.1	5.7	1,800	3.9
6	LEL0080*±6ECA	1/20	1.0	182	1.1	15	2,100	9.1	5.7	1,800	3.9
6	LEL0100*±6ECA	1/20	1.0	182	1.1	15	2,100	9.1	5.7	1,800	3.9
6	LEL0130*±6ECA	1/20	1.5	273	1.6	15	3,150	13.7	8.5	2,700	5.9
6	LEL0155*±6ECA	1/20	1.5	273	1.6	15	3,150	13.7	8.5	2,700	5.9
6	LEL0170*±6ECA	1/20	2.0	364	2.1	15	4,200	18.3	11.4	3,600	7.8
6	LEL0205*±6ECA	1/20	2.0	364	2.1	15	4,200	18.3	11.4	3,600	7.8
6	LEL0240*±6ECA	1/20	2.5	455	2.6	15	5,250	22.8	14.2	4,500	9.8
6	LEL0255*±6ECA	1/20	3.0	546	3.1	15	6,300	27.4	17.1	5,400	11.7
6	LEL0310*±6ECA	1/20	3.0	546	3.1	15	6,300	27.4	17.1	5,400	11.7
4	LEL0045*±4ECA	1/20	0.5	91	0.6	15	1,050	4.6	2.8	900	2.0
4	LEL0070*±4ECA	1/20	1.0	182	1.1	15	2,100	9.1	5.7	1,800	3.9
4	LEL0090*±4ECA	1/20	1.0	182	1.1	15	2,100	9.1	5.7	1,800	3.9
4	LEL0135*±4ECA	1/20	1.5	273	1.6	15	3,150	13.7	8.5	2,700	5.9
4	LEL0180*±4ECA	1/20	2.0	364	2.1	15	4,200	18.3	11.4	3,600	7.8
4	LEL0220*±4ECA	1/20	2.5	455	2.6	15	5,250	22.8	14.2	4,500	9.8
4	LEL0275*±4ECA	1/20	3.0	546	3.1	15	6,300	27.4	17.1	5,400	11.7

FPI	New Model	HP	PSC Motor (Totally Enclosed)				Defrost Heaters-230V			Defrost Heaters-460V	
			460/1/60				Watts	230/1/60	230/3/60	Watts	460/1/60
			Amps	Watts	MCA	MOPD					
6	LEL0040*±6ECA	1/20	0.4	117	0.5	15	1,050	4.6	2.8	900	2.0
6	LEL0045*±6ECA	1/20	0.4	117	0.5	15	1,050	4.6	2.8	900	2.0
6	LEL0065*±6ECA	1/20	0.8	234	0.9	15	2,100	9.1	5.7	1,800	3.9
6	LEL0080*±6ECA	1/20	0.8	234	0.9	15	2,100	9.1	5.7	1,800	3.9
6	LEL0100*±6ECA	1/20	0.8	234	0.9	15	2,100	9.1	5.7	1,800	3.9
6	LEL0130*±6ECA	1/20	1.2	351	1.3	15	3,150	13.7	8.5	2,700	5.9
6	LEL0155*±6ECA	1/20	1.2	351	1.3	15	3,150	13.7	8.5	2,700	5.9
6	LEL0170*±6ECA	1/20	1.6	468	1.7	15	4,200	18.3	11.4	3,600	7.8
6	LEL0205*±6ECA	1/20	1.6	468	1.7	15	4,200	18.3	11.4	3,600	7.8
6	LEL0240*±6ECA	1/20	2.0	585	2.1	15	5,250	22.8	14.2	4,500	9.8
6	LEL0255*±6ECA	1/20	2.4	702	2.5	15	6,300	27.4	17.1	5,400	11.7
6	LEL0310*±6ECA	1/20	2.4	702	2.5	15	6,300	27.4	17.1	5,400	11.7
4	LEL0045*±4ECA	1/20	0.4	117	0.5	15	1,050	4.6	2.8	900	2.0
4	LEL0070*±4ECA	1/20	0.8	234	0.9	15	2,100	9.1	5.7	1,800	3.9
4	LEL0090*±4ECA	1/20	0.8	234	0.9	15	2,100	9.1	5.7	1,800	3.9
4	LEL0135*±4ECA	1/20	1.2	351	1.3	15	3,150	13.7	8.5	2,700	5.9
4	LEL0180*±4ECA	1/20	1.6	468	1.7	15	4,200	18.3	11.4	3,600	7.8
4	LEL0220*±4ECA	1/20	2.0	585	2.1	15	5,250	22.8	14.2	4,500	9.8
4	LEL0275*±4ECA	1/20	2.4	702	2.5	15	6,300	27.4	17.1	5,400	11.7

Notes:
 * = Electrical Code Designator (see Nomenclature details)
 ± = Refrigerant Designator (see Nomenclature details)

SPECIFICATIONS

Electric Defrost- 50 Hz

Please consult AWEF table on pages 44 & 45 to confirm model meets DOE minimum AWEF

FPI	New Model	HP	2-Speed EC Motor (Totally Enclosed)				Defrost Heaters	
			220/1/50				Watts	220/1/50 Total Amps
			Amps	Watts	MCA	MOPD		
6	LEL0040*±6EMA	1/20	0.5	55	0.6	15	960	4.4
6	LEL0045*±6EMA	1/20	0.5	55	0.6	15	960	4.4
6	LEL0065*±6EMA	1/20	1.0	110	1.1	15	1,920	8.7
6	LEL0080*±6EMA	1/20	1.0	110	1.1	15	1,920	8.7
6	LEL0100*±6EMA	1/20	1.0	110	1.1	15	1,920	8.7
6	LEL0130*±6EMA	1/20	1.5	165	1.6	15	2,880	13.1
6	LEL0155*±6EMA	1/20	1.5	165	1.6	15	2,880	13.1
6	LEL0170*±6EMA	1/20	2.0	220	2.1	15	3,845	17.5
6	LEL0205*±6EMA	1/20	2.0	220	2.1	15	3,845	17.5
6	LEL0240*±6EMA	1/20	2.5	275	2.6	15	4,805	21.8
6	LEL0255*±6EMA	1/20	3.0	330	3.1	15	5,765	26.2
6	LEL0310*±6EMA	1/20	3.0	330	3.1	15	5,765	26.2
4	LEL0045*±4EMA	1/20	0.5	55	0.6	15	960	4.4
4	LEL0070*±4EMA	1/20	1.0	110	1.1	15	1,920	8.7
4	LEL0090*±4EMA	1/20	1.0	110	1.1	15	1,920	8.7
4	LEL0135*±4EMA	1/20	1.5	165	1.6	15	2,880	13.1
4	LEL0180*±4EMA	1/20	2.0	220	2.1	15	3,845	17.5
4	LEL0220*±4EMA	1/20	2.5	275	2.6	15	4,805	21.8
4	LEL0275*±4EMA	1/20	3.0	330	3.1	15	5,765	26.2

FPI	New Model	HP	1-Speed EC Motor (Totally Enclosed)				Defrost Heaters	
			220/1/50				Watts	220/1/50 Total Amps
			Amps	Watts	MCA	MOPD		
6	LEL0040*±6EEA	1/20	0.5	59	0.6	15	960	4.4
6	LEL0045*±6EEA	1/20	0.5	59	0.6	15	960	4.4
6	LEL0065*±6EEA	1/20	1.0	118	1.1	15	1,920	8.7
6	LEL0080*±6EEA	1/20	1.0	118	1.1	15	1,920	8.7
6	LEL0100*±6EEA	1/20	1.0	118	1.1	15	1,920	8.7
6	LEL0130*±6EEA	1/20	1.5	177	1.6	15	2,880	13.1
6	LEL0155*±6EEA	1/20	1.5	177	1.6	15	2,880	13.1
6	LEL0170*±6EEA	1/20	2.0	236	2.1	15	3,845	17.5
6	LEL0205*±6EEA	1/20	2.0	236	2.1	15	3,845	17.5
6	LEL0240*±6EEA	1/20	2.5	295	2.6	15	4,805	21.8
6	LEL0255*±6EEA	1/20	3.0	354	3.1	15	5,765	26.2
6	LEL0310*±6EEA	1/20	3.0	354	3.1	15	5,765	26.2
4	LEL0045*±4EEA	1/20	0.5	59	0.6	15	960	4.4
4	LEL0070*±4EEA	1/20	1.0	118	1.1	15	1,920	8.7
4	LEL0090*±4EEA	1/20	1.0	118	1.1	15	1,920	8.7
4	LEL0135*±4EEA	1/20	1.5	177	1.6	15	2,880	13.1
4	LEL0180*±4EEA	1/20	2.0	236	2.1	15	3,845	17.5
4	LEL0220*±4EEA	1/20	2.5	295	2.6	15	4,805	21.8
4	LEL0275*±4EEA	1/20	3.0	354	3.1	15	5,765	26.2

Notes:

* = Electrical Code Designator (see Nomenclature details)

± = Refrigerant Designator (see Nomenclature details)

SPECIFICATIONS

Electric Defrost- 50 Hz

Please consult AWEF table on pages 44 & 45 to confirm model meets DOE minimum AWEF

FPI	New Model	HP	PSC Motor (Totally Enclosed)				Defrost Heaters	
			220/1/50				Watts	220/1/50
			Amps	Watts	MCA	MOPD		Total Amps
6	LEL0040*±6ECA	1/20	0.5	65	0.6	15	960	4.4
6	LEL0045*±6ECA	1/20	0.5	65	0.6	15	960	4.4
6	LEL0065*±6ECA	1/20	1.0	130	1.1	15	1,920	8.7
6	LEL0080*±6ECA	1/20	1.0	130	1.1	15	1,920	8.7
6	LEL0100*±6ECA	1/20	1.0	130	1.1	15	1,920	8.7
6	LEL0130*±6ECA	1/20	1.5	195	1.6	15	2,880	13.1
6	LEL0155*±6ECA	1/20	1.5	195	1.6	15	2,880	13.1
6	LEL0170*±6ECA	1/20	2.0	260	2.1	15	3,845	17.5
6	LEL0205*±6ECA	1/20	2.0	260	2.1	15	3,845	17.5
6	LEL0240*±6ECA	1/20	2.5	325	2.6	15	4,805	21.8
6	LEL0255*±6ECA	1/20	3.0	390	3.1	15	5,765	26.2
6	LEL0310*±6ECA	1/20	3.0	390	3.1	15	5,765	26.2
4	LEL0045*±4ECA	1/20	0.5	65	0.6	15	960	4.4
4	LEL0070*±4ECA	1/20	1.0	130	1.1	15	1,920	8.7
4	LEL0090*±4ECA	1/20	1.0	130	1.1	15	1,920	8.7
4	LEL0135*±4ECA	1/20	1.5	195	1.6	15	2,880	13.1
4	LEL0180*±4ECA	1/20	2.0	260	2.1	15	3,845	17.5
4	LEL0220*±4ECA	1/20	2.5	325	2.6	15	4,805	21.8
4	LEL0275*±4ECA	1/20	3.0	390	3.1	15	5,765	26.2

Notes:

* = Electrical Code Designator (see Nomenclature details)

± = Refrigerant Designator (see Nomenclature details)

PERFORMANCE DATA

Application Capacity: Low Temperature Hot Gas Defrost- 60 Hz

Please consult AWEF table on pages 46 & 47 to confirm model meets DOE minimum AWEF

Please refer to Table 1: Capacity Correction Factors (page 6) if using Saturated Suction Temperatures different than listed in the information below

FPI	New Model	Legacy Model	R-404A/R-507A		R-448A/R-449A		Fan Data		
			Application Capacity ¹		Application Capacity ¹				
			10°F TD/-20°F SST	6°C TD/-29°C SST	10°F TD/-20°F SST	6°C TD/-29°C SST	No. of Fans	CFM	m ³ H
			BTUH	Watts	BTUH	Watts			
6	LEL0040*S6H^A	LCH635	3,500	1,000	3,900	1,000	1	685	1,164
6	LEL0045*S6H^A	LCH643	4,700	1,400	5,300	1,600	1	641	1,088
6	LEL0065*S6H^A	LCH665	6,500	1,900	7,200	2,100	2	1,371	2,329
6	LEL0080*S6H^A	LCH676	7,500	2,200	8,400	2,500	2	1,371	2,329
6	LEL0100*S6H^A	LCH694	9,000	2,600	9,900	2,900	2	1,281	2,176
6	LEL0130*S6H^A	LCH6120	12,000	3,500	13,500	4,000	3	2,056	3,493
6	LEL0155*S6H^A	LCH6140	14,000	4,100	16,000	4,700	3	1,922	3,265
6	LEL0170*S6H^A	LCH6160	16,000	4,700	17,900	5,200	4	2,741	4,658
6	LEL0205*S6H^A	LCH6180	18,000	5,300	20,100	5,900	4	2,562	4,353
6	LEL0240*S6H^A	LCH6200	20,000	5,900	22,800	6,600	5	3,203	5,441
6	LEL0255*S6H^A	LCH6240	24,000	7,000	26,900	7,900	6	4,112	6,986
6	LEL0310*S6H^A	LCH6270	28,000	8,200	31,400	9,200	6	3,843	6,529
4	LEL0045*S4H^A	LCH441	4,100	1,200	4,500	1,300	1	667	1,132
4	LEL0070*S4H^A	LCH457 LCH467	6,800	2,000	7,400	2,200	2	1,425	2,422
4	LEL0090*S4H^A	LCH482	8,000	2,300	8,800	2,600	2	1,332	2,263
4	LEL0135*S4H^A	LCH4105	10,200	3,000	12,800	3,700	3	1,998	3,395
4	LEL0180*S4H^A	LCH4139	13,600	4,000	17,300	5,000	4	2,664	4,527
4	LEL0220*S4H^A	LCH4174	17,000	5,000	19,500	5,600	5	3,331	5,659
4	LEL0275*S4H^A	LCH4208 LCH4235	23,500	6,900	25,900	7,600	6	3,997	6,790

Notes:

¹ = Capacities shown are Application Capacities reflecting nominal operation at 10°F TD. For models within the scope of the DOE AWEF (Annual Walk-in Energy Factor) standard, the Net Capacity is determined by the AHRI 1250 test method. DOE will publish this compliance data at www.regulations.doe.gov

* = Electrical Code Designator (see Nomenclature details)

^ = Motor Code Designator (see Nomenclature details)

Net Capacity is available upon request

PERFORMANCE DATA

Application Capacity: Low Temperature Hot Gas Defrost- 60 Hz

Please consult AWEF table on pages 46 & 47 to confirm model meets DOE minimum AWEF

Please refer to Table 1: Capacity Correction Factors (page 6) if using Saturated Suction Temperatures different than listed in the information below

FPI	New Model	Legacy Model	R-407A/R-407F		R-407C		Fan Data		
			Application Capacity ¹		Application Capacity ¹				
			10°F TD/-20°F SST	6°C TD/-29°C SST	10°F TD/-20°F SST	6°C TD/-29°C SST	No. of Fans	CFM	m ³ H
			BTUH	Watts	BTUH	Watts			
6	LEL0040*S6H^A	LCH635	3,900	1,000	-	-	1	685	1,164
6	LEL0045*S6H^A	LCH643	5,300	1,600	-	-	1	641	1,088
6	LEL0065*S6H^A	LCH665	7,200	2,100	-	-	2	1,371	2,329
6	LEL0080*S6H^A	LCH676	8,400	2,500	-	-	2	1,371	2,329
6	LEL0100*S6H^A	LCH694	9,900	2,900	-	-	2	1,281	2,176
6	LEL0130*S6H^A	LCH6120	13,500	4,000	-	-	3	2,056	3,493
6	LEL0155*S6H^A	LCH6140	16,000	4,700	-	-	3	1,922	3,265
6	LEL0170*S6H^A	LCH6160	17,900	5,200	-	-	4	2,741	4,658
6	LEL0205*S6H^A	LCH6180	20,100	5,900	-	-	4	2,562	4,353
6	LEL0240*S6H^A	LCH6200	22,400	6,500	-	-	5	3,203	5,441
6	LEL0255*S6H^A	LCH6240	26,900	7,900	-	-	6	4,112	6,986
6	LEL0310*S6H^A	LCH6270	31,400	9,200	-	-	6	3,843	6,529
4	LEL0045*S4H^A	LCH441	4,500	1,300	-	-	1	667	1,132
4	LEL0070*S4H^A	LCH457 LCH467	7,400	2,200	-	-	2	1,425	2,422
4	LEL0090*S4H^A	LCH482	8,800	2,600	-	-	2	1,332	2,263
4	LEL0135*S4H^A	LCH4105	12,100	3,500	-	-	3	1,998	3,395
4	LEL0180*S4H^A	LCH4139	16,300	4,700	-	-	4	2,664	4,527
4	LEL0220*S4H^A	LCH4174	19,000	5,500	-	-	5	3,331	5,659
4	LEL0275*S4H^A	LCH4208 LCH4235	25,900	7,600	-	-	6	3,997	6,790

Notes:
¹ = Capacities shown are Application Capacities reflecting nominal operation at 10°F TD. For models within the scope of the DOE AWEF (Annual Walk-in Energy Factor) standard, the Net Capacity is determined by the AHRI 1250 test method. DOE will publish this compliance data at www.regulations.doe.gov
 * = Electrical Code Designator (see Nomenclature details)
 ^ = Motor Code Designator (see Nomenclature details)
 Net Capacity is available upon request

PERFORMANCE DATA

Application Capacity: Low Temperature Hot Gas Defrost- 50 Hz (For PSC Motors)[†]

Please consult AWEF table on pages 46 & 47 to confirm model meets DOE minimum AWEF

Please refer to Table 1: Capacity Correction Factors (page 6) if using Saturated Suction Temperatures different than listed in the information below

FPI	New Model	Legacy Model	R-404A/R-507A		R-448A/R-449A		Fan Data		
			Application Capacity ¹		Application Capacity ¹				
			10°F TD/-20°F SST	6°C TD/-29°C SST	10°F TD/-20°F SST	6°C TD/-29°C SST	No. of Fans	CFM	m ³ H
			BTUH	Watts	BTUH	Watts			
6	LEL0040*S6H^A	LCH635	3,325	950	3,705	950	1	617	1,048
6	LEL0045*S6H^A	LCH643	4,465	1,330	5,035	1,520	1	576	979
6	LEL0065*S6H^A	LCH665	6,175	1,805	6,840	1,995	2	1,234	2,096
6	LEL0080*S6H^A	LCH676	7,125	2,090	7,980	2,375	2	1,234	2,096
6	LEL0100*S6H^A	LCH694	8,550	2,470	9,405	2,755	2	1,153	1,959
6	LEL0130*S6H^A	LCH6120	11,400	3,325	12,825	3,800	3	1,850	3,144
6	LEL0155*S6H^A	LCH6140	13,300	3,895	15,200	4,465	3	1,729	2,938
6	LEL0170*S6H^A	LCH6160	15,200	4,465	17,005	4,940	4	2,467	4,192
6	LEL0205*S6H^A	LCH6180	17,100	5,035	19,095	5,605	4	2,306	3,918
6	LEL0240*S6H^A	LCH6200	19,000	5,605	21,660	6,270	5	2,882	4,897
6	LEL0255*S6H^A	LCH6240	22,800	6,650	25,555	7,505	6	3,701	6,288
6	LEL0310*S6H^A	LCH6270	26,600	7,790	29,830	8,740	6	2,459	5,876
4	LEL0045*S4H^A	LCH441	3,895	1,140	4,275	1,235	1	600	1,019
4	LEL0070*S4H^A	LCH457 LCH467	6,460	1,900	7,030	2,090	2	1,283	2,180
4	LEL0090*S4H^A	LCH482	7,600	2,185	8,360	2,470	2	1,199	2,037
4	LEL0135*S4H^A	LCH4105	9,690	2,850	12,160	3,515	3	1,799	3,056
4	LEL0180*S4H^A	LCH4139	12,920	3,800	16,435	4,750	4	2,398	4,074
4	LEL0220*S4H^A	LCH4174	16,150	4,750	18,525	5,320	5	2,998	5,093
4	LEL0275*S4H^A	LCH4208 LCH4235	22,325	6,555	24,605	7,220	6	3,597	6,111

Notes:

¹ = Capacities shown are Application Capacities reflecting nominal operation at 10°F TD. For models within the scope of the DOE AWEF (Annual Walk-in Energy Factor) standard, the Net Capacity is determined by the AHRI 1250 test method. DOE will publish this compliance data at www.regulations.doe.gov

* = Electrical Code Designator (see Nomenclature details)

^ = Motor Code Designator (see Nomenclature details)

Net Capacity is available upon request

[†] = For 1-speed and 2-speed EC motors, use 60 Hz capacity and airflow values. (units with EC motors operating at 50 Hz will not see a reduction in performance due to the electronic control of the motor)

PERFORMANCE DATA

Application Capacity: Low Temperature Hot Gas Defrost- 50 Hz (For PSC Motors)[†]

Please consult AWEF table on pages 46 & 47 to confirm model meets DOE minimum AWEF

Please refer to Table 1: Capacity Correction Factors (page 6) if using Saturated Suction Temperatures different than listed in the information below

FPI	New Model	Legacy Model	R-407A/R-407F		R-407C		Fan Data		
			Application Capacity ¹		Application Capacity ¹				
			10°F TD/-20°F SST	6°C TD/-29°C SST	10°F TD/-20°F SST	6°C TD/-29°C SST	No. of Fans	CFM	m ³ H
			BTUH	Watts	BTUH	Watts			
6	LEL0040*S6H^A	LCH635	3,705	950	-	-	1	617	1,048
6	LEL0045*S6H^A	LCH643	5,035	1,520	-	-	1	576	979
6	LEL0065*S6H^A	LCH665	6,840	1,995	-	-	2	1,234	2,096
6	LEL0080*S6H^A	LCH676	7,980	2,375	-	-	2	1,234	2,096
6	LEL0100*S6H^A	LCH694	9,405	2,755	-	-	2	1,153	1,959
6	LEL0130*S6H^A	LCH6120	12,825	3,800	-	-	3	1,850	3,144
6	LEL0155*S6H^A	LCH6140	15,200	4,465	-	-	3	1,729	2,938
6	LEL0170*S6H^A	LCH6160	17,005	4,940	-	-	4	2,467	4,192
6	LEL0205*S6H^A	LCH6180	19,095	5,605	-	-	4	2,306	3,918
6	LEL0240*S6H^A	LCH6200	21,280	6,175	-	-	5	2,882	4,897
6	LEL0255*S6H^A	LCH6240	25,555	7,505	-	-	6	3,701	6,288
6	LEL0310*S6H^A	LCH6270	29,830	8,740	-	-	6	2,459	5,876
4	LEL0045*S4H^A	LCH441	4,275	1,235	-	-	1	600	1,019
4	LEL0070*S4H^A	LCH457 LCH467	7,030	2,090	-	-	2	1,283	2,180
4	LEL0090*S4H^A	LCH482	8,360	2,470	-	-	2	1,199	2,037
4	LEL0135*S4H^A	LCH4105	11,495	3,325	-	-	3	1,799	3,056
4	LEL0180*S4H^A	LCH4139	15,485	4,465	-	-	4	2,398	4,074
4	LEL0220*S4H^A	LCH4174	18,050	5,225	-	-	5	2,998	5,093
4	LEL0275*S4H^A	LCH4208 LCH4235	24,605	7,220	-	-	6	3,597	6,111

Notes:

¹ = Capacities shown are Application Capacities reflecting nominal operation at 10°F TD. For models within the scope of the DOE AWEF (Annual Walk-in Energy Factor) standard, the Net Capacity is determined by the AHRI 1250 test method. DOE will publish this compliance data at www.regulations.doe.gov

* = Electrical Code Designator (see Nomenclature details)

^ = Motor Code Designator (see Nomenclature details)

Net Capacity is available upon request

[†] = For 1-speed and 2-speed EC motors, use 60 Hz capacity and airflow values. (units with EC motors operating at 50 Hz will not see a reduction in performance due to the electronic control of the motor)

PERFORMANCE DATA

Application Capacity: Medium Temperature Hot Gas Defrost- 60 Hz

Please consult AWEF table on pages 46 & 47 to confirm model meets DOE minimum AWEF

Please refer to Table 1: Capacity Correction Factors (page 6) if using Saturated Suction Temperatures different than listed in the information below

FPI	New Model	Legacy Model	R-404A/R-507A		R-448A/R-449A		Fan Data		
			Application Capacity ¹		Application Capacity ¹				
			10°F TD/-20°F SST	6°C TD/-4°C SST	10°F TD/-20°F SST	6°C TD/-4°C SST	No. of Fans	CFM	m ³ H
			BTUH	Watts	BTUH	Watts			
6	LEL0040*S6H^A	LCH635	4,000	1,200	4,500	1,300	1	685	1,164
6	LEL0045*S6H^A	LCH643	5,400	1,550	6,100	1,750	1	641	1,088
6	LEL0065*S6H^A	LCH665	7,450	2,150	8,300	2,400	2	1,371	2,329
6	LEL0080*S6H^A	LCH676	8,650	2,500	9,650	2,800	2	1,371	2,329
6	LEL0100*S6H^A	LCH694	10,350	3,000	11,400	3,300	2	1,281	2,176
6	LEL0130*S6H^A	LCH6120	13,800	4,000	15,500	4,500	3	2,056	3,493
6	LEL0155*S6H^A	LCH6140	16,100	4,650	18,400	5,300	3	1,922	3,265
6	LEL0170*S6H^A	LCH6160	18,400	5,300	20,600	5,950	4	2,741	4,658
6	LEL0205*S6H^A	LCH6180	20,700	6,000	23,100	6,650	4	2,562	4,353
6	LEL0240*S6H^A	LCH6200	23,000	6,650	25,750	7,450	5	3,203	5,441
6	LEL0255*S6H^A	LCH6240	27,600	7,950	30,950	8,950	6	4,112	6,986
6	LEL0310*S6H^A	LCH6270	32,200	9,300	36,100	10,400	6	3,843	6,529
4	LEL0045*S4H^A	LCH441	4,700	1,400	5,200	1,500	1	667	1,132
4	LEL0070*S4H^A	LCH457 LCH467	7,800	2,250	8,500	2,450	2	1,425	2,422
4	LEL0090*S4H^A	LCH482	9,200	2,650	10,100	2,900	2	1,332	2,263
4	LEL0135*S4H^A	LCH4105	11,750	3,400	13,050	3,800	3	1,998	3,395
4	LEL0180*S4H^A	LCH4139	15,650	4,500	17,650	5,100	4	2,664	4,527
4	LEL0220*S4H^A	LCH4174	19,550	5,650	21,850	6,300	5	3,331	5,659
4	LEL0275*S4H^A	LCH4208 LCH4235	27,000	7,800	29,800	8,600	6	3,997	6,790

Notes:

¹ = Capacities shown are Application Capacities reflecting nominal operation at 10°F TD. For models within the scope of the DOE AWEF (Annual Walk-in Energy Factor) standard, the Net Capacity is determined by the AHRI 1250 test method. DOE will publish this compliance data at www.regulations.doe.gov

* = Electrical Code Designator (see Nomenclature details)

^ = Motor Code Designator (see Nomenclature details)

Net Capacity is available upon request

PERFORMANCE DATA

Application Capacity: Medium Temperature Hot Gas Defrost- 60 Hz

Please consult AWEF table on pages 46 & 47 to confirm model meets DOE minimum AWEF

Please refer to Table 1: Capacity Correction Factors (page 6) if using Saturated Suction Temperatures different than listed in the information below

FPI	New Model	Legacy Model	R-407A/R-407F		R-407C		Fan Data		
			Application Capacity ¹		Application Capacity ¹				
			10°F TD/-20°F SST	6°C TD/-4°C SST	10°F TD/-20°F SST	6°C TD/-4°C SST	No. of Fans	CFM	m ³ H
			BTUH	Watts	BTUH	Watts			
6	LEL0040*S6H^A	LCH635	4,500	1,300	-	-	1	685	1,164
6	LEL0045*S6H^A	LCH643	6,100	1,750	-	-	1	641	1,088
6	LEL0065*S6H^A	LCH665	8,300	2,400	-	-	2	1,371	2,329
6	LEL0080*S6H^A	LCH676	9,650	2,800	-	-	2	1,371	2,329
6	LEL0100*S6H^A	LCH694	11,400	3,300	-	-	2	1,281	2,176
6	LEL0130*S6H^A	LCH6120	15,500	4,500	-	-	3	2,056	3,493
6	LEL0155*S6H^A	LCH6140	18,400	5,300	-	-	3	1,922	3,265
6	LEL0170*S6H^A	LCH6160	20,600	5,950	-	-	4	2,741	4,658
6	LEL0205*S6H^A	LCH6180	23,100	6,650	-	-	4	2,562	4,353
6	LEL0240*S6H^A	LCH6200	25,750	7,450	-	-	5	3,203	5,441
6	LEL0255*S6H^A	LCH6240	30,950	8,950	-	-	6	4,112	6,986
6	LEL0310*S6H^A	LCH6270	36,100	10,400	-	-	6	3,843	6,529
4	LEL0045*S4H^A	LCH441	5,200	1,500	-	-	1	667	1,132
4	LEL0070*S4H^A	LCH457 LCH467	8,500	2,450	-	-	2	1,425	2,422
4	LEL0090*S4H^A	LCH482	10,100	2,900	-	-	2	1,332	2,263
4	LEL0135*S4H^A	LCH4105	13,050	3,800	-	-	3	1,998	3,395
4	LEL0180*S4H^A	LCH4139	17,650	5,100	-	-	4	2,664	4,527
4	LEL0220*S4H^A	LCH4174	21,850	6,300	-	-	5	3,331	5,659
4	LEL0275*S4H^A	LCH4208 LCH4235	29,800	8,600	-	-	6	3,997	6,790

Notes:
¹ = Capacities shown are Application Capacities reflecting nominal operation at 10°F TD. For models within the scope of the DOE AWEF (Annual Walk-in Energy Factor) standard, the Net Capacity is determined by the AHRI 1250 test method. DOE will publish this compliance data at www.regulations.doe.gov
 * = Electrical Code Designator (see Nomenclature details)
 ^ = Motor Code Designator (see Nomenclature details)
 Net Capacity is available upon request

SPECIFICATIONS

Hot Gas Defrost- 60 Hz

Please consult AWEF table on pages 46 & 47 to confirm model meets DOE minimum AWEF

FPI	New Model	HP	2-Speed EC Motor (Totally Enclosed)				Drain Pan Heaters			
			115/1/60				Watts	115/1/60	230/1/60	460/1/60
			Amps	Watts	MCA	MOPD		Total Amps		
6	LEL0040*S6HMA	1/20	0.9	55	1.1	20	150	1.3	0.7	0.3
6	LEL0045*S6HMA	1/20	0.9	55	1.1	20	150	1.3	0.7	0.3
6	LEL0065*S6HMA	1/20	1.8	110	2.0	20	300	2.6	1.3	0.7
6	LEL0080*S6HMA	1/20	1.8	110	2.0	20	300	2.6	1.3	0.7
6	LEL0100*S6HMA	1/20	1.8	110	2.0	20	300	2.6	1.3	0.7
6	LEL0130*S6HMA	1/20	2.7	165	2.9	20	450	3.9	2.0	1.0
6	LEL0155*S6HMA	1/20	2.7	165	2.9	20	450	3.9	2.0	1.0
6	LEL0170*S6HMA	1/20	3.6	220	3.8	20	600	5.2	2.6	1.3
6	LEL0205*S6HMA	1/20	3.6	220	3.8	20	600	5.2	2.6	1.3
6	LEL0240*S6HMA	1/20	4.5	275	4.7	20	750	6.5	3.3	1.6
6	LEL0255*S6HMA	1/20	5.4	330	5.6	20	900	7.8	3.9	2.0
6	LEL0310*S6HMA	1/20	5.4	330	5.6	20	900	7.8	3.9	2.0
4	LEL0045*S4HMA	1/20	0.9	55	1.1	20	150	1.3	0.7	0.3
4	LEL0070*S4HMA	1/20	1.8	110	2.0	20	300	2.6	1.3	0.7
4	LEL0090*S4HMA	1/20	1.8	110	2.0	20	300	2.6	1.3	0.7
4	LEL0135*S4HMA	1/20	2.7	165	2.9	20	450	3.9	2.0	1.0
4	LEL0180*S4HMA	1/20	3.6	220	3.8	20	600	5.2	2.6	1.3
4	LEL0220*S4HMA	1/20	4.5	275	4.7	20	750	6.5	3.3	1.6
4	LEL0275*S4HMA	1/20	5.4	330	5.6	20	900	7.8	3.9	2.0

FPI	New Model	HP	2-Speed EC Motor (Totally Enclosed)				Drain Pan Heaters			
			208-230/1/60				Watts	115/1/60	230/1/60	460/1/60
			Amps	Watts	MCA	MOPD		Total Amps		
6	LEL0040*S6HMA	1/20	0.5	55	0.6	15	150	1.3	0.7	0.3
6	LEL0045*S6HMA	1/20	0.5	55	0.6	15	150	1.3	0.7	0.3
6	LEL0065*S6HMA	1/20	1.0	110	1.1	15	300	2.6	1.3	0.7
6	LEL0080*S6HMA	1/20	1.0	110	1.1	15	300	2.6	1.3	0.7
6	LEL0100*S6HMA	1/20	1.0	110	1.1	15	300	2.6	1.3	0.7
6	LEL0130*S6HMA	1/20	1.4	165	1.6	15	450	3.9	2.0	1.0
6	LEL0155*S6HMA	1/20	1.4	165	1.6	15	450	3.9	2.0	1.0
6	LEL0170*S6HMA	1/20	1.9	220	2.1	15	600	5.2	2.6	1.3
6	LEL0205*S6HMA	1/20	1.9	220	2.1	15	600	5.2	2.6	1.3
6	LEL0240*S6HMA	1/20	2.4	275	2.6	15	750	6.5	3.3	1.6
6	LEL0255*S6HMA	1/20	2.9	330	3.1	15	900	7.8	3.9	2.0
6	LEL0310*S6HMA	1/20	2.9	330	3.1	15	900	7.8	3.9	2.0
4	LEL0045*S4HMA	1/20	0.5	55	0.6	15	150	1.3	0.7	0.3
4	LEL0070*S4HMA	1/20	1.0	110	1.1	15	300	2.6	1.3	0.7
4	LEL0090*S4HMA	1/20	1.0	110	1.1	15	300	2.6	1.3	0.7
4	LEL0135*S4HMA	1/20	1.4	165	1.6	15	450	3.9	2.0	1.0
4	LEL0180*S4HMA	1/20	1.9	220	2.1	15	600	5.2	2.6	1.3
4	LEL0220*S4HMA	1/20	2.4	275	2.6	15	750	6.5	3.3	1.6
4	LEL0275*S4HMA	1/20	2.9	330	3.1	15	900	7.8	3.9	2.0

Notes:

* = Electrical Code Designator (see Nomenclature details)

^ = Motor Code Designator (see Nomenclature details)

SPECIFICATIONS

Hot Gas Defrost- 60 Hz

Please consult AWEF table on pages 46 & 47 to confirm model meets DOE minimum AWEF

FPI	New Model	HP	1-Speed EC Motor (Totally Enclosed)				Watts	Drain Pan Heaters		
			115/1/60					115/1/60	230/1/60	460/1/60
			Amps	Watts	MCA	MOPD				
6	LEL0040*S6HEA	1/20	0.9	55	1.1	20	150	1.3	0.7	0.3
6	LEL0045*S6HEA	1/20	0.9	55	1.1	20	150	1.3	0.7	0.3
6	LEL0065*S6HEA	1/20	1.8	110	2.0	20	300	2.6	1.3	0.7
6	LEL0080*S6HEA	1/20	1.8	110	2.0	20	300	2.6	1.3	0.7
6	LEL0100*S6HEA	1/20	1.8	110	2.0	20	300	2.6	1.3	0.7
6	LEL0130*S6HEA	1/20	2.7	165	2.9	20	450	3.9	2.0	1.0
6	LEL0155*S6HEA	1/20	2.7	165	2.9	20	450	3.9	2.0	1.0
6	LEL0170*S6HEA	1/20	3.6	220	3.8	20	600	5.2	2.6	1.3
6	LEL0205*S6HEA	1/20	3.6	220	3.8	20	600	5.2	2.6	1.3
6	LEL0240*S6HEA	1/20	4.5	270	4.7	20	750	6.5	3.3	1.6
6	LEL0255*S6HEA	1/20	5.4	330	5.6	20	900	7.8	3.9	2.0
6	LEL0310*S6HEA	1/20	5.4	330	5.6	20	900	7.8	3.9	2.0
4	LEL0045*S4HEA	1/20	0.9	55	1.1	20	150	1.3	0.7	0.3
4	LEL0070*S4HEA	1/20	1.8	110	2.0	20	300	2.6	1.3	0.7
4	LEL0090*S4HEA	1/20	1.8	110	2.0	20	300	2.6	1.3	0.7
4	LEL0135*S4HEA	1/20	2.7	165	2.9	20	450	3.9	2.0	1.0
4	LEL0180*S4HEA	1/20	3.6	220	3.8	20	600	5.2	2.6	1.3
4	LEL0220*S4HEA	1/20	4.5	275	4.7	20	750	6.5	3.3	1.6
4	LEL0275*S4HEA	1/20	5.4	330	5.6	20	900	7.8	3.9	2.0

FPI	New Model	HP	1-Speed EC Motor (Totally Enclosed)				Watts	Drain Pan Heaters		
			208-230/1/60					115/1/60	230/1/60	460/1/60
			Amps	Watts	MCA	MOPD				
6	LEL0040*S6HEA	1/20	0.5	59	0.6	15	150	1.3	0.7	0.3
6	LEL0045*S6HEA	1/20	0.5	59	0.6	15	150	1.3	0.7	0.3
6	LEL0065*S6HEA	1/20	1.0	118	1.1	15	300	2.6	1.3	0.7
6	LEL0080*S6HEA	1/20	1.0	118	1.1	15	300	2.6	1.3	0.7
6	LEL0100*S6HEA	1/20	1.0	118	1.1	15	300	2.6	1.3	0.7
6	LEL0130*S6HEA	1/20	1.5	177	1.6	15	450	3.9	2.0	1.0
6	LEL0155*S6HEA	1/20	1.5	177	1.6	15	450	3.9	2.0	1.0
6	LEL0170*S6HEA	1/20	2.0	236	2.1	15	600	5.2	2.6	1.3
6	LEL0205*S6HEA	1/20	2.0	236	2.1	15	600	5.2	2.6	1.3
6	LEL0240*S6HEA	1/20	2.5	295	2.6	15	750	6.5	3.3	1.6
6	LEL0255*S6HEA	1/20	3.0	354	3.1	15	900	7.8	3.9	2.0
6	LEL0310*S6HEA	1/20	3.0	354	3.1	15	900	7.8	3.9	2.0
4	LEL0045*S4HEA	1/20	0.5	59	0.6	15	150	1.3	0.7	0.3
4	LEL0070*S4HEA	1/20	1.0	118	1.1	15	300	2.6	1.3	0.7
4	LEL0090*S4HEA	1/20	1.0	118	1.1	15	300	2.6	1.3	0.7
4	LEL0135*S4HEA	1/20	1.5	177	1.6	15	450	3.9	2.0	1.0
4	LEL0180*S4HEA	1/20	2.0	236	2.1	15	600	5.2	2.6	1.3
4	LEL0220*S4HEA	1/20	2.5	295	2.6	15	750	6.5	3.3	1.6
4	LEL0275*S4HEA	1/20	3.0	354	3.1	15	900	7.8	3.9	2.0

Notes:

* = Electrical Code Designator (see Nomenclature details)

SPECIFICATIONS

Hot Gas Defrost- 60 Hz

Please consult AWEF table on pages 46 & 47 to confirm model meets DOE minimum AWEF

FPI	New Model	HP	PSC Motor (Totally Enclosed)				Drain Pan Heaters			
			115/1/60				Watts	115/1/60	230/1/60	460/1/60
			Amps	Watts	MCA	MOPD		Total Amps		
6	LEL0040*S6HCA	1/20	1.0	82	1.3	20	150	1.3	0.7	0.3
6	LEL0045*S6HCA	1/20	1.0	82	1.3	20	150	1.3	0.7	0.3
6	LEL0065*S6HCA	1/20	2.0	164	2.3	20	300	2.6	1.3	0.7
6	LEL0080*S6HCA	1/20	2.0	164	2.3	20	300	2.6	1.3	0.7
6	LEL0100*S6HCA	1/20	2.0	164	2.3	20	300	2.6	1.3	0.7
6	LEL0130*S6HCA	1/20	3.0	246	3.3	20	450	3.9	2.0	1.0
6	LEL0155*S6HCA	1/20	3.0	246	3.3	20	450	3.9	2.0	1.0
6	LEL0170*S6HCA	1/20	4.0	328	4.3	20	600	5.2	2.6	1.3
6	LEL0205*S6HCA	1/20	4.0	328	4.3	20	600	5.2	2.6	1.3
6	LEL0240*S6HCA	1/20	5.0	410	5.3	20	750	6.5	3.3	1.6
6	LEL0255*S6HCA	1/20	6.0	492	6.3	20	900	7.8	3.9	2.0
6	LEL0310*S6HCA	1/20	6.0	492	6.3	20	900	7.8	3.9	2.0
4	LEL0045*S4HCA	1/20	1.0	82	1.3	20	150	1.3	0.7	0.3
4	LEL0070*S4HCA	1/20	2.0	164	2.3	20	300	2.6	1.3	0.7
4	LEL0090*S4HCA	1/20	2.0	164	2.3	20	300	2.6	1.3	0.7
4	LEL0135*S4HCA	1/20	3.0	246	3.3	20	450	3.9	2.0	1.0
4	LEL0180*S4HCA	1/20	4.0	328	4.3	20	600	5.2	2.6	1.3
4	LEL0220*S4HCA	1/20	5.0	410	5.3	20	750	6.5	3.3	1.6
4	LEL0275*S4HCA	1/20	6.0	492	6.3	20	900	7.8	3.9	2.0

FPI	New Model	HP	PSC Motor (Totally Enclosed)				Drain Pan Heaters			
			208-230/1/60				Watts	115/1/60	230/1/60	460/1/60
			Amps	Watts	MCA	MOPD		Total Amps		
6	LEL0040*S6HCA	1/20	0.5	91	0.6	15	150	1.3	0.7	0.3
6	LEL0045*S6HCA	1/20	0.5	91	0.6	15	150	1.3	0.7	0.3
6	LEL0065*S6HCA	1/20	1.0	182	1.1	15	300	2.6	1.3	0.7
6	LEL0080*S6HCA	1/20	1.0	182	1.1	15	300	2.6	1.3	0.7
6	LEL0100*S6HCA	1/20	1.0	182	1.1	15	300	2.6	1.3	0.7
6	LEL0130*S6HCA	1/20	1.5	273	1.6	15	450	3.9	2.0	1.0
6	LEL0155*S6HCA	1/20	1.5	273	1.6	15	450	3.9	2.0	1.0
6	LEL0170*S6HCA	1/20	2.0	364	2.1	15	600	5.2	2.6	1.3
6	LEL0205*S6HCA	1/20	2.0	364	2.1	15	600	5.2	2.6	1.3
6	LEL0240*S6HCA	1/20	2.5	455	2.6	15	750	6.5	3.3	1.6
6	LEL0255*S6HCA	1/20	3.0	546	3.1	15	900	7.8	3.9	2.0
6	LEL0310*S6HCA	1/20	3.0	546	3.1	15	900	7.8	3.9	2.0
4	LEL0045*S4HCA	1/20	0.5	91	0.6	15	150	1.3	0.7	0.3
4	LEL0070*S4HCA	1/20	1.0	182	1.1	15	300	2.6	1.3	0.7
4	LEL0090*S4HCA	1/20	1.0	182	1.1	15	300	2.6	1.3	0.7
4	LEL0135*S4HCA	1/20	1.5	273	1.6	15	450	3.9	2.0	1.0
4	LEL0180*S4HCA	1/20	2.0	364	2.1	15	600	5.2	2.6	1.3
4	LEL0220*S4HCA	1/20	2.5	455	2.6	15	750	6.5	3.3	1.6
4	LEL0275*S4HCA	1/20	3.0	546	3.1	15	900	7.8	3.9	2.0

Notes:

* = Electrical Code Designator (see Nomenclature details)

SPECIFICATIONS

Hot Gas Defrost- 60 Hz

Please consult AWEF table on pages 46 & 47 to confirm model meets DOE minimum AWEF

FPI	New Model	HP	PSC Motor (Totally Enclosed)				Drain Pan Heaters			
			460/1/60				Watts	115/1/60	230/1/60	460/1/60
			Amps	Watts	MCA	MOPD		Total Amps		
6	LEL0040*S6HCA	1/20	0.4	117	0.5	15	150	1.3	0.7	0.3
6	LEL0045*S6HCA	1/20	0.4	117	0.5	15	150	1.3	0.7	0.3
6	LEL0065*S6HCA	1/20	0.8	234	0.9	15	300	2.6	1.3	0.7
6	LEL0080*S6HCA	1/20	0.8	234	0.9	15	300	2.6	1.3	0.7
6	LEL0100*S6HCA	1/20	0.8	234	0.9	15	300	2.6	1.3	0.7
6	LEL0130*S6HCA	1/20	1.2	351	1.3	15	450	3.9	2.0	1.0
6	LEL0155*S6HCA	1/20	1.2	351	1.3	15	450	3.9	2.0	1.0
6	LEL0170*S6HCA	1/20	1.6	468	1.7	15	600	5.2	2.6	1.3
6	LEL0205*S6HCA	1/20	1.6	468	1.7	15	600	5.2	2.6	1.3
6	LEL0240*S6HCA	1/20	2.0	585	2.1	15	750	6.5	3.3	1.6
6	LEL0255*S6HCA	1/20	2.4	702	2.5	15	900	7.8	3.9	2.0
6	LEL0310*S6HCA	1/20	2.4	702	2.5	15	900	7.8	3.9	2.0
4	LEL0045*S4HCA	1/20	0.4	117	0.5	15	150	1.3	0.7	0.3
4	LEL0070*S4HCA	1/20	0.8	234	0.9	15	300	2.6	1.3	0.7
4	LEL0090*S4HCA	1/20	0.8	234	0.9	15	300	2.6	1.3	0.7
4	LEL0135*S4HCA	1/20	1.2	351	1.3	15	450	3.9	2.0	1.0
4	LEL0180*S4HCA	1/20	1.6	468	1.7	15	600	5.2	2.6	1.3
4	LEL0220*S4HCA	1/20	2.0	585	2.1	15	750	6.5	3.3	1.6
4	LEL0275*S4HCA	1/20	2.4	702	2.5	15	900	7.8	3.9	2.0

Notes:

* = Electrical Code Designator (see Nomenclature details)

SPECIFICATIONS

Hot Gas Defrost- 50 Hz

Please consult AWEF table on pages 46 & 47 to confirm model meets DOE minimum AWEF

FPI	New Model	HP	2-Speed EC Motor (Totally Enclosed)				Drain Pan Heaters	
			220/1/50				Watts	220/1/50
			Amps	Watts	MCA	MOPD		Total Amps
6	LEL0040*S6HMA	1/20	0.5	55	0.6	15	135	0.6
6	LEL0045*S6HMA	1/20	0.5	55	0.6	15	135	0.6
6	LEL0065*S6HMA	1/20	1.0	110	1.1	15	275	1.2
6	LEL0080*S6HMA	1/20	1.0	110	1.1	15	275	1.2
6	LEL0100*S6HMA	1/20	1.0	110	1.1	15	275	1.2
6	LEL0130*S6HMA	1/20	1.5	165	1.6	15	410	1.9
6	LEL0155*S6HMA	1/20	1.5	165	1.6	15	410	1.9
6	LEL0170*S6HMA	1/20	2.0	220	2.1	15	550	2.5
6	LEL0205*S6HMA	1/20	2.0	220	2.1	15	550	2.5
6	LEL0240*S6HMA	1/20	2.5	275	2.6	15	690	3.1
6	LEL0255*S6HMA	1/20	3.0	330	3.1	15	825	3.7
6	LEL0310*S6HMA	1/20	3.0	330	3.1	15	825	3.7
4	LEL0045*S4HMA	1/20	0.5	55	0.6	15	135	0.6
4	LEL0070*S4HMA	1/20	1.0	110	1.1	15	275	1.2
4	LEL0090*S4HMA	1/20	1.0	110	1.1	15	275	1.2
4	LEL0135*S4HMA	1/20	1.5	165	1.6	15	410	1.9
4	LEL0180*S4HMA	1/20	2.0	220	2.1	15	550	2.5
4	LEL0220*S4HMA	1/20	2.5	275	2.6	15	690	3.1
4	LEL0275*S4HMA	1/20	3.0	330	3.1	15	825	3.7

FPI	New Model	HP	1-Speed EC Motor (Totally Enclosed)				Drain Pan Heaters	
			220/1/50				Watts	220/1/50
			Amps	Watts	MCA	MOPD		Total Amps
6	LEL0040*S6HEA	1/20	0.5	59	0.6	15	135	0.6
6	LEL0045*S6HEA	1/20	0.5	59	0.6	15	135	0.6
6	LEL0065*S6HEA	1/20	1.0	118	1.1	15	275	1.2
6	LEL0080*S6HEA	1/20	1.0	118	1.1	15	275	1.2
6	LEL0100*S6HEA	1/20	1.0	118	1.1	15	275	1.2
6	LEL0130*S6HEA	1/20	1.5	177	1.6	15	410	1.9
6	LEL0155*S6HEA	1/20	1.5	177	1.6	15	410	1.9
6	LEL0170*S6HEA	1/20	2.0	236	2.1	15	550	2.5
6	LEL0205*S6HEA	1/20	2.0	236	2.1	15	550	2.5
6	LEL0240*S6HEA	1/20	2.5	295	2.6	15	690	3.1
6	LEL0255*S6HEA	1/20	3.0	354	3.1	15	825	3.7
6	LEL0310*S6HEA	1/20	3.0	354	3.1	15	825	3.7
4	LEL0045*S4HEA	1/20	0.5	59	0.6	15	135	0.6
4	LEL0070*S4HEA	1/20	1.0	118	1.1	15	275	1.2
4	LEL0090*S4HEA	1/20	1.0	118	1.1	15	275	1.2
4	LEL0135*S4HEA	1/20	1.5	177	1.6	15	410	1.9
4	LEL0180*S4HEA	1/20	2.0	236	2.1	15	550	2.5
4	LEL0220*S4HEA	1/20	2.5	295	2.6	15	690	3.1
4	LEL0275*S4HEA	1/20	3.0	354	3.1	15	825	3.7

Notes:

* = Electrical Code Designator (see Nomenclature details)

SPECIFICATIONS

Hot Gas Defrost- 50 Hz

Please consult AWEF table on pages 46 & 47 to confirm model meets DOE minimum AWEF

FPI	New Model	HP	PSC Motor (Totally Enclosed)				Drain Pan Heaters	
			220/1/50				Watts	220/1/50
			Amps	Watts	MCA	MOPD		Total Amps
6	LEL0040*S6HCA	1/20	0.5	65	0.6	15	135	0.6
6	LEL0045*S6HCA	1/20	0.5	65	0.6	15	135	0.6
6	LEL0065*S6HCA	1/20	1.0	130	1.1	15	275	1.2
6	LEL0080*S6HCA	1/20	1.0	130	1.1	15	275	1.2
6	LEL0100*S6HCA	1/20	1.0	130	1.1	15	275	1.2
6	LEL0130*S6HCA	1/20	1.5	195	1.6	15	410	1.9
6	LEL0155*S6HCA	1/20	1.5	195	1.6	15	410	1.9
6	LEL0170*S6HCA	1/20	2.0	260	2.1	15	550	2.5
6	LEL0205*S6HCA	1/20	2.0	260	2.1	15	550	2.5
6	LEL0240*S6HCA	1/20	2.5	325	2.6	15	690	3.1
6	LEL0255*S6HCA	1/20	3.0	390	3.1	15	825	3.7
6	LEL0310*S6HCA	1/20	3.0	390	3.1	15	825	3.7
4	LEL0045*S4HCA	1/20	0.5	65	0.6	15	135	0.6
4	LEL0070*S4HCA	1/20	1.0	130	1.1	15	275	1.2
4	LEL0090*S4HCA	1/20	1.0	130	1.1	15	275	1.2
4	LEL0135*S4HCA	1/20	1.5	195	1.6	15	410	1.9
4	LEL0180*S4HCA	1/20	2.0	260	2.1	15	550	2.5
4	LEL0220*S4HCA	1/20	2.5	325	2.6	15	690	3.1
4	LEL0275*S4HCA	1/20	3.0	390	3.1	15	825	3.7

Notes:

* = Electrical Code Designator (see Nomenclature details)

PHYSICAL DATA

Air Defrost (R-404A/R-507A, R-448A/R-449A, R-407A/R-407F, R-407C)

Model	No. of Fans	Coil Inlet OD	Suction OD	Equalizer OD	Drain MPT	Approx. Net Weight	
						lb	kg
LEL0045*S6A^A	1	1/2	1/2	1/4	3/4	33	15
LEL0055*S6A^A	1	1/2	5/8	1/4	3/4	36	16
LEL0060*S6A^A	1	1/2	5/8	1/4	3/4	36	16
LEL0095*S6A^A	2	1/2	5/8	1/4	3/4	51	23
LEL0105*S6A^A	2	1/2	5/8	1/4	3/4	52	24
LEL0115*S6A^A	2	1/2	5/8	1/4	3/4	56	26
LEL0125*S6A^A	2	1/2	7/8	1/4	3/4	56	26
LEL0155*S6A^A	3	1/2	7/8	1/4	3/4	67	30
LEL0190*S6A^A	3	1/2	7/8	1/4	3/4	73	33
LEL0250*S6A^A	4	1/2	7/8	1/4	3/4	94	43
LEL0295*S6A^A	5	1/2	7/8	1/4	3/4	115	52
LEL0350*S6A^A	6	1/2	1-1/8	1/4	3/4	133	60
LEL0380*S6A^A	6	1/2	1-1/8	1/4	3/4	137	62

Air Defrost (CO₂DX)

Model	No. of Fans	Coil Inlet ²	Suction OD ²	Drain MPT	Approx. Net Weight	
					lb	kg
LEL0045*C6A^A	1	3/8	3/8	3/4	33	15
LEL0055*C6A^A	1	3/8	3/8	3/4	36	16
LEL0060*C6A^A	1	3/8	3/8	3/4	36	16
LEL0095*C6A^A	2	3/8	3/8	3/4	51	23
LEL0105*C6A^A	2	3/8	3/8	3/4	52	24
LEL0115*C6A^A	2	3/8	3/8	3/4	56	26
LEL0125*C6A^A	2	3/8	3/8	3/4	56	26
LEL0155*C6A^A	3	3/8	3/8	3/4	67	30
LEL0190*C6A^A	3	3/8	3/8	3/4	73	33
LEL0250*C6A^A	4	3/8	1/2	3/4	94	43
LEL0295*C6A^A	5	3/8	1/2	3/4	115	52
LEL0350*C6A^A	6	3/8	1/2	3/4	133	60
LEL0380*C6A^A	6	1/2	5/8	3/4	137	62

Notes:

* = Electrical Code Designator (see Nomenclature details)

^ = Motor Code Designator (see Nomenclature details)

² = Connection sizes may vary, if TD is lesser or greater than 10°F

PHYSICAL DATA

Electric Defrost (R-404A/R-507A, R-448A/R-449A, R-407A/R-407F, R-407C)

Model	No. of Fans	Coil Inlet OD	Suction OD	Equalizer OD	Drain MPT	Approx. Net Weight	
						lb	kg
LEL0045*S6A^A	1	1/2	1/2	1/4	3/4	33	15
LEL0055*S6A^A	1	1/2	5/8	1/4	3/4	36	16
LEL0060*S6A^A	1	1/2	5/8	1/4	3/4	36	16
LEL0095*S6A^A	2	1/2	5/8	1/4	3/4	51	23
LEL0105*S6A^A	2	1/2	5/8	1/4	3/4	52	24
LEL0115*S6A^A	2	1/2	7/8	1/4	3/4	56	26
LEL0125*S6A^A	2	1/2	7/8	1/4	3/4	56	26
LEL0155*S6A^A	3	1/2	7/8	1/4	3/4	67	30
LEL0190*S6A^A	3	1/2	7/8	1/4	3/4	73	33
LEL0250*S6A^A	4	1/2	7/8	1/4	3/4	94	43
LEL0295*S6A^A	5	1/2	7/8	1/4	3/4	115	52
LEL0350*S6A^A	6	1/2	1-1/8	1/4	3/4	133	60
LEL0380*S6A^A	6	1/2	1-1/8	1/4	3/4	137	62

Electric Defrost (CO₂DX)

FPI	Model	No. of Fans	Coil Inlet ²	Suction OD ²	Drain MPT	Approx. Net Weight	
						lb	kg
6	LEL0040*C6E^A	1	3/8	3/8	36	16	16
6	LEL0045*C6E^A	1	3/8	3/8	38	17	17
6	LEL0065*C6E^A	2	3/8	3/8	54	24	24
6	LEL0080*C6E^A	2	3/8	1/2	54	24	24
6	LEL0100*C6E^A	2	3/8	1/2	59	27	27
6	LEL0130*C6E^A	3	3/8	1/2	71	32	32
6	LEL0155*C6E^A	3	3/8	1/2	78	35	35
6	LEL0170*C6E^A	4	3/8	1/2	91	41	41
6	LEL0205*C6E^A	4	3/8	1/2	100	45	45
6	LEL0240*C6E^A	5	3/8	5/8	120	54	54
6	LEL0255*C6E^A	6	3/8	5/8	134	61	61
6	LEL0310*C6E^A	6	3/8	5/8	146	66	66
4	LEL0045*C4E^A	1	3/8	3/8	38	17	17
4	LEL0070*C4E^A	2	3/8	3/8	53	24	24
4	LEL0090*C4E^A	2	3/8	1/2	59	27	27
4	LEL0135*C4E^A	3	3/8	1/2	77	35	35
4	LEL0180*C4E^A	4	3/8	1/2	100	45	45
4	LEL0220*C4E^A	5	3/8	1/2	119	54	54
4	LEL0275*C4E^A	6	3/8	5/8	142	64	64

Notes:

* = Electrical Code Designator (see Nomenclature details)

^ = Motor Code Designator (see Nomenclature details)

² = Connection sizes may vary, if TD is lesser or greater than 10°F

PHYSICAL DATA

Hot Gas Defrost

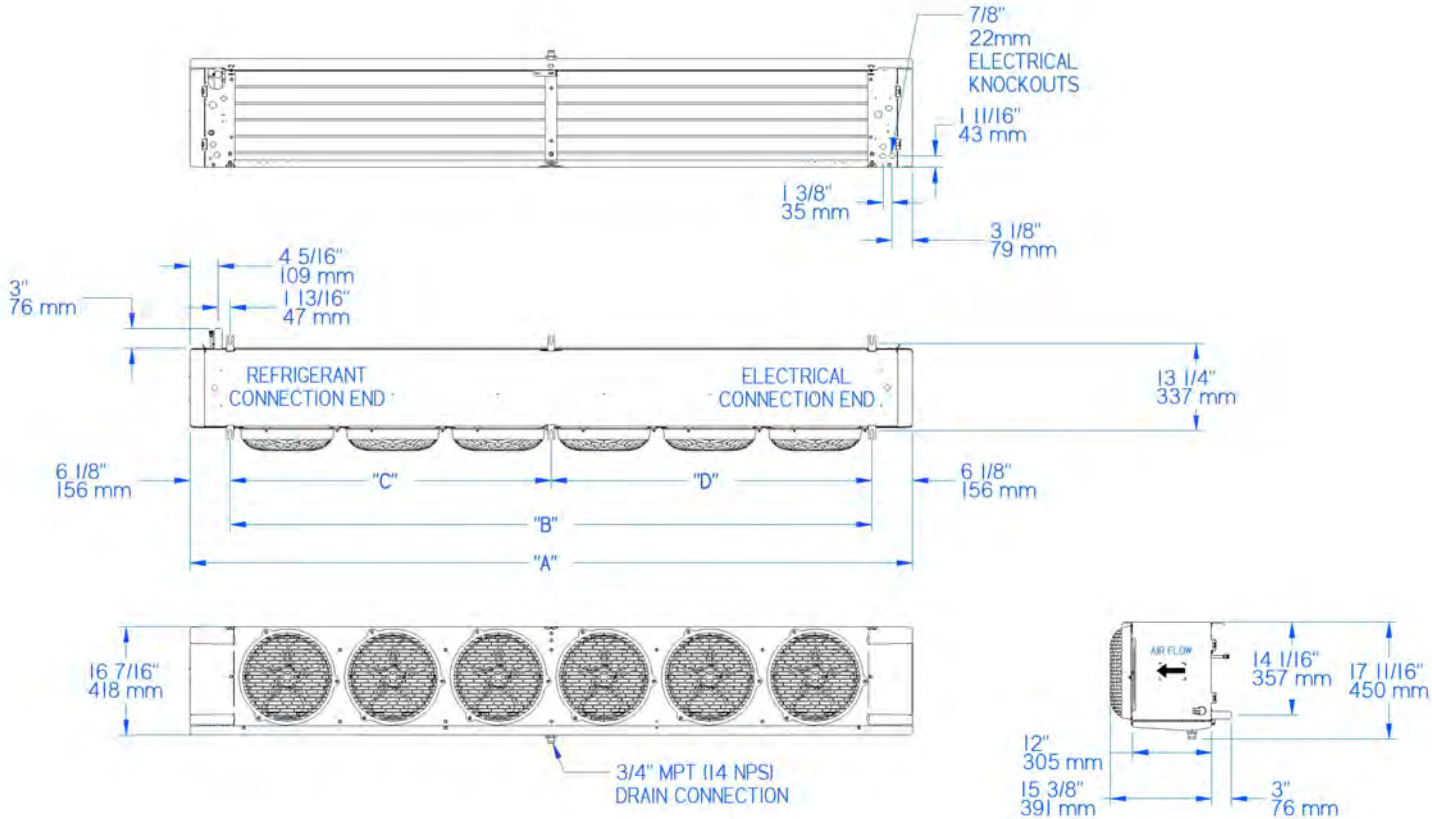
FPI	Model	No. of Fans	Coil Inlet OD	Suction OD	Equalizer OD	Drain MPT	Side Port OD	Hot Gas Pan Connection OD	Approx. Net Weight	
									lb	kg
6	LEL0040*S6H^A	1	1/2	5/8	1/4	3/4	1/2	5/8	38	17
6	LEL0045*S6H^A	1	1/2	5/8	1/4	3/4	1/2	5/8	40	18
6	LEL0065*S6H^A	2	1/2	5/8	1/4	3/4	1/2	5/8	56	25
6	LEL0080*S6H^A	2	1/2	5/8	1/4	3/4	1/2	5/8	56	25
6	LEL0100*S6H^A	2	1/2	7/8	1/4	3/4	1/2	5/8	61	27
6	LEL0130*S6H^A	3	1/2	7/8	1/4	3/4	1/2	5/8	73	33
6	LEL0155*S6H^A	3	1/2	1-1/8	1/4	3/4	1/2	5/8	80	36
6	LEL0170*S6H^A	4	1/2	7/8	1/4	3/4	1/2	5/8	93	42
6	LEL0205*S6H^A	4	1/2	1-1/8	1/4	3/4	1/2	5/8	102	46
6	LEL0240*S6H^A	5	1/2	1-1/8	1/4	3/4	1/2	5/8	122	55
6	LEL0255*S6H^A	6	1/2	1-1/8	1/4	3/4	1/2	5/8	136	62
6	LEL0310*S6H^A	6	1/2	1-1/8	1/4	3/4	1/2	5/8	148	67
4	LEL0045*S4H^A	1	1/2	5/8	1/4	3/4	1/2	5/8	40	18
4	LEL0070*S4H^A	2	1/2	5/8	1/4	3/4	1/2	5/8	55	25
4	LEL0090*S4H^A	2	1/2	7/8	1/4	3/4	1/2	5/8	61	28
4	LEL0135*S4H^A	3	1/2	7/8	1/4	3/4	1/2	5/8	79	36
4	LEL0180*S4H^A	4	1/2	1-1/8	1/4	3/4	1/2	5/8	102	46
4	LEL0220*S4H^A	5	1/2	1-1/8	1/4	3/4	1/2	5/8	121	55
4	LEL0275*S4H^A	6	1/2	1-1/8	1/4	3/4	1/2	5/8	144	65

Notes:

* = Electrical Code Designator (see Nomenclature details)

^ = Motor Code Designator (see Nomenclature details)

DIMENSIONAL DRAWINGS



No. of Fans	A		B		C		D	
	in.	mm	in.	mm	in.	mm	in.	mm
1	29.5	749	17.25	438	-	-	-	-
2	45.5	1,156	33.25	845	-	-	-	-
3	61.5	1,562	49.25	1,251	-	-	-	-
4	77.5	1,969	65.25	1,657	-	-	-	-
5	93.5	2,375	81.25	2,064	48.63	1,235	32.63	829
6	109.5	2,781	97.25	2,470	48.63	1,235	48.63	1,235

Note:
Hanger brackets will accept 3/8" / 9.5 mm hanger rods

DOE Rated AWEF

AWEF DATA

Air Defrost/2-Speed EC Motors

FPI	Model	Cooler				
		R-404A/ R-507A	R-448A/ R-449A	R-407A/ R-407F	R-407C	CO ₂ DX
		AWEF	AWEF	AWEF	AWEF	AWEF
6	LEL0045*S6AMA	9.00	9.00	9.00	9.00	9.00
6	LEL0055*S6AMA	9.00	9.00	9.00	9.00	9.00
6	LEL0060*S6AMA	9.00	9.00	9.00	9.00	9.00
6	LEL0095*S6AMA	9.00	9.00	9.00	9.00	9.00
6	LEL0105*S6AMA	9.00	9.00	9.00	9.00	9.00
6	LEL0115*S6AMA	9.00	9.00	9.00	9.00	9.00
6	LEL0125*S6AMA	9.00	9.00	9.00	9.00	9.00
6	LEL0155*S6AMA	9.00	9.00	9.00	9.00	9.00
6	LEL0190*S6AMA	9.00	9.00	9.00	9.00	9.00
6	LEL0250*S6AMA	9.00	9.00	9.00	9.00	9.00
6	LEL0295*S6AMA	9.00	9.00	9.00	9.00	9.00
6	LEL0350*S6AMA	9.00	9.00	9.00	9.00	9.00
6	LEL0380*S6AMA	9.00	9.00	9.00	9.00	9.00

DOE Rated AWEF

AWEF DATA

Electric Defrost/1-Speed EC Motors

FPI	Model	Freezer				
		R-404A/ R-507A	R-448A/ R-449A	R-407A/ R-407F	R-407C	CO ₂ DX
		AWEF	AWEF	AWEF	AWEF	AWEF
6	LEL0040*±6EEA	3.96	3.96	3.96	-	3.96
6	LEL0045*±6EEA	3.96	3.96	3.96	-	3.96
6	LEL0065*±6EEA	4.00	4.03	4.02	-	4.00
6	LEL0080*±6EEA	4.03	4.03	4.03	-	4.03
6	LEL0100*±6EEA	4.00	4.06	4.06	-	4.00
6	LEL0130*±6EEA	4.09	4.09	4.09	-	4.09
6	LEL0155*±6EEA	4.10	4.10	4.10	-	4.10
6	LEL0170*±6EEA	4.14	4.14	4.14	-	4.14
6	LEL0205*±6EEA	4.15	4.15	4.15	-	4.15
6	LEL0240*±6EEA	4.15	4.15	4.15	-	4.15
6	LEL0255*±6EEA	4.15	4.15	4.15	-	4.15
6	LEL0310*±6EEA	4.15	4.15	4.15	-	4.15
4	LEL0045*±4EEA	3.96	3.96	3.96	-	3.96
4	LEL0070*±4EEA	3.99	3.99	3.99	-	-
4	LEL0090*±4EEA	4.02	4.02	4.02	-	4.02
4	LEL0135*±4EEA	4.07	4.07	4.07	-	4.07
4	LEL0180*±4EEA	4.12	4.12	4.12	-	4.12
4	LEL0220*±4EEA	4.15	4.15	4.15	-	4.15
4	LEL0275*±4EEA	4.15	4.15	4.15	-	4.15

DOE Rated AWEF

AWEF DATA

Electric Defrost/2-Speed EC Motors

FPI	Model	Cooler				
		R-404A/ R-507A	R-448A/ R-449A	R-407A/ R-407F	R-407C	CO ₂ DX
		AWEF	AWEF	AWEF	AWEF	AWEF
6	LEL0040*±6EMA	9.00	9.00	9.00	-	9.00
6	LEL0045*±6EMA	9.00	9.00	9.00	-	9.00
6	LEL0065*±6EMA	9.00	9.00	9.00	-	9.00
6	LEL0080*±6EMA	9.00	9.00	9.00	-	9.00
6	LEL0100*±6EMA	9.00	9.00	9.00	-	9.00
6	LEL0130*±6EMA	9.00	9.00	9.00	-	9.00
6	LEL0155*±6EMA	9.00	9.00	9.00	-	9.00
6	LEL0170*±6EMA	9.00	9.00	9.00	-	9.00
6	LEL0205*±6EMA	9.00	9.00	9.00	-	9.00
6	LEL0240*±6EMA	9.00	9.00	9.00	-	9.00
6	LEL0255*±6EMA	9.00	9.00	9.00	-	9.00
6	LEL0310*±6EMA	9.00	9.00	9.00	-	9.00
4	LEL0045*±4EMA	9.00	9.00	9.00	-	9.00
4	LEL0070*±4EMA	9.00	9.00	9.00	-	-
4	LEL0090*±4EMA	9.00	9.00	9.00	-	9.00
4	LEL0135*±4EMA	9.00	9.00	9.00	-	9.00
4	LEL0180*±4EMA	9.00	9.00	9.00	-	9.00
4	LEL0220*±4EMA	9.00	9.00	9.00	-	9.00
4	LEL0275*±4EMA	9.00	9.00	9.00	-	9.00

FPI	Model	Freezer				
		R-404A/ R-507A	R-448A/ R-449A	R-407A/ R-407F	R-407C	CO ₂ DX
		AWEF	AWEF	AWEF	AWEF	AWEF
6	LEL0040*±6EMA	3.96	3.96	3.96	-	3.96
6	LEL0045*±6EMA	3.96	3.96	3.96	-	3.96
6	LEL0065*±6EMA	4.00	4.03	4.02	-	4.00
6	LEL0080*±6EMA	4.00	4.00	4.00	-	4.00
6	LEL0100*±6EMA	4.03	4.03	4.03	-	4.03
6	LEL0130*±6EMA	4.06	4.06	4.06	-	4.06
6	LEL0155*±6EMA	4.09	4.09	4.09	-	4.09
6	LEL0170*±6EMA	4.10	4.10	4.10	-	4.10
6	LEL0205*±6EMA	4.14	4.14	4.14	-	4.14
6	LEL0240*±6EMA	4.15	4.15	4.15	-	4.15
6	LEL0255*±6EMA	4.15	4.15	4.15	-	4.15
6	LEL0310*±6EMA	4.15	4.15	4.15	-	4.15
4	LEL0045*±4EMA	3.96	3.96	3.96	-	3.96
4	LEL0070*±4EMA	3.99	3.99	3.99	-	-
4	LEL0090*±4EMA	4.02	4.02	4.02	-	4.02
4	LEL0135*±4EMA	4.07	4.07	4.07	-	4.07
4	LEL0180*±4EMA	4.12	4.12	4.12	-	4.12
4	LEL0220*±4EMA	4.15	4.15	4.15	-	4.15
4	LEL0275*±4EMA	4.15	4.15	4.15	-	4.15

DOE Rated AWEF

AWEF DATA

Hot Gas Defrost/1-Speed EC Motors

FPI	Model	Freezer			
		R-404A/ R-507A	R-448A/ R-449A	R-407A/ R-407F	R-407C
		AWEF	AWEF	AWEF	AWEF
6	LEL0040*S6HEA	3.96	3.96	3.96	-
6	LEL0045*S6HEA	3.96	3.96	3.96	-
6	LEL0065*S6HEA	4.00	4.03	4.02	-
6	LEL0080*S6HEA	4.03	4.03	4.03	-
6	LEL0100*S6HEA	4.06	4.06	4.06	-
6	LEL0130*S6HEA	4.09	4.09	4.09	-
6	LEL0155*S6HEA	4.10	4.10	4.10	-
6	LEL0170*S6HEA	4.14	4.14	4.14	-
6	LEL0205*S6HEA	4.15	4.15	4.15	-
6	LEL0240*S6HEA	4.15	4.15	4.15	-
6	LEL0255*S6HEA	4.15	4.15	4.15	-
6	LEL0310*S6HEA	4.15	4.15	4.15	-
4	LEL0045*S4HEA	3.96	3.96	3.96	-
4	LEL0070*S4HEA	3.99	3.99	3.99	-
4	LEL0090*S4HEA	4.02	4.02	4.02	-
4	LEL0135*S4HEA	4.07	4.07	4.07	-
4	LEL0180*S4HEA	4.12	4.12	4.12	-
4	LEL0220*S4HEA	4.15	4.15	4.15	-
4	LEL0275*S4HEA	4.15	4.15	4.15	-

DOE Rated AWEF

AWEF DATA

Hot Gas Defrost/2-Speed EC Motors

FPI	Model	Cooler			
		R-404A/ R-507A	R-448A/ R-449A	R-407A/ R-407F	R-407C
		AWEF	AWEF	AWEF	AWEF
6	LEL0040*S6HMA	9.00	9.00	9.00	-
6	LEL0045*S6HMA	9.00	9.00	9.00	-
6	LEL0065*S6HMA	9.00	9.00	9.00	-
6	LEL0080*S6HMA	9.00	9.00	9.00	-
6	LEL0100*S6HMA	9.00	9.00	9.00	-
6	LEL0130*S6HMA	9.00	9.00	9.00	-
6	LEL0155*S6HMA	9.00	9.00	9.00	-
6	LEL0170*S6HMA	9.00	9.00	9.00	-
6	LEL0205*S6HMA	9.00	9.00	9.00	-
6	LEL0240*S6HMA	9.00	9.00	9.00	-
6	LEL0255*S6HMA	9.00	9.00	9.00	-
6	LEL0310*S6HMA	9.00	9.00	9.00	-
4	LEL0045*S4HMA	9.00	9.00	9.00	-
4	LEL0070*S4HMA	9.00	9.00	9.00	-
4	LEL0090*S4HMA	9.00	9.00	9.00	-
4	LEL0135*S4HMA	9.00	9.00	9.00	-
4	LEL0180*S4HMA	9.00	9.00	9.00	-
4	LEL0220*S4HMA	9.00	9.00	9.00	-
4	LEL0275*S4HMA	9.00	9.00	9.00	-

FPI	Model	Freezer			
		R-404A/ R-507A	R-448A/ R-449A	R-407A/ R-407F	R-407C
		AWEF	AWEF	AWEF	AWEF
6	LEL0040*S6HMA	3.96	3.96	3.96	-
6	LEL0045*S6HMA	3.96	3.96	3.96	-
6	LEL0065*S6HMA	4.00	4.03	4.02	-
6	LEL0080*S6HMA	4.00	4.00	4.00	-
6	LEL0100*S6HMA	4.03	4.03	4.03	-
6	LEL0130*S6HMA	4.06	4.06	4.06	-
6	LEL0155*S6HMA	4.09	4.09	4.09	-
6	LEL0170*S6HMA	4.10	4.10	4.10	-
6	LEL0205*S6HMA	4.14	4.14	4.14	-
6	LEL0240*S6HMA	4.15	4.15	4.15	-
6	LEL0255*S6HMA	4.15	4.15	4.15	-
6	LEL0310*S6HMA	4.15	4.15	4.15	-
4	LEL0045*S4HMA	3.96	3.96	3.96	-
4	LEL0070*S4HMA	3.99	3.99	3.99	-
4	LEL0090*S4HMA	4.02	4.02	4.02	-
4	LEL0135*S4HMA	4.07	4.07	4.07	-
4	LEL0180*S4HMA	4.12	4.12	4.12	-
4	LEL0220*S4HMA	4.15	4.15	4.15	-
4	LEL0275*S4HMA	4.15	4.15	4.15	-

HOT GAS REVERSE CYCLE KITS

Shipped Loose Accessories

FPI	Model	TXV Bypass and Liquid Line Piping Kit (Reverse Cycle)	TXV Liquid Line Piping Kit (Three Pipe or Rev Cycle w/o TXV Bypass)	Suction/Drain Pan Check Valve Piping Kit (Reverse Cycle)	Drain Pan Check Valve Piping Kit (Three Pipe)
		For TXV's SBF/SQE/BBI/EG	For TXV's SBF/SQE/BBI/EG		
6	LEL0040*S6H^A	50756301	50756302	50692204	50692302
6	LEL0045*S6H^A	50756301	50756302	50692204	50692302
6	LEL0065*S6H^A	50756301	50756302	50692204	50692302
6	LEL0080*S6H^A	50756301	50756302	50692204	50692302
6	LEL0100*S6H^A	50756301	50756302	50692225	50692302
6	LEL0130*S6H^A	50756301	50756302	50692225	50692302
6	LEL0155*S6H^A	50756301	50756302	50692206	50692302
6	LEL0170*S6H^A	50756301	50756302	50692205	50692302
6	LEL0205*S6H^A	50756301	50756302	50692206	50692302
6	LEL0240*S6H^A	50756301	50756302	50692206	50692302
6	LEL0255*S6H^A	50756301	50756302	50692206	50692302
6	LEL0310*S6H^A	50756301	50756302	50692206	50692302
4	LEL0045*S4H^A	50756301	50756302	50692204	50692302
4	LEL0070*S4H^A	50756301	50756302	50692204	50692302
4	LEL0090*S4H^A	50756301	50756302	50692205	50692302
4	LEL0135*S4H^A	50756301	50756302	50692205	50692302
4	LEL0180*S4H^A	50756301	50756302	50692206	50692302
4	LEL0220*S4H^A	50756301	50756302	50692206	50692302
4	LEL0275*S4H^A	50756301	50756302	50692206	50692302

REVERSE CYCLE PIPING

Reverse cycle defrost unit cooler operation

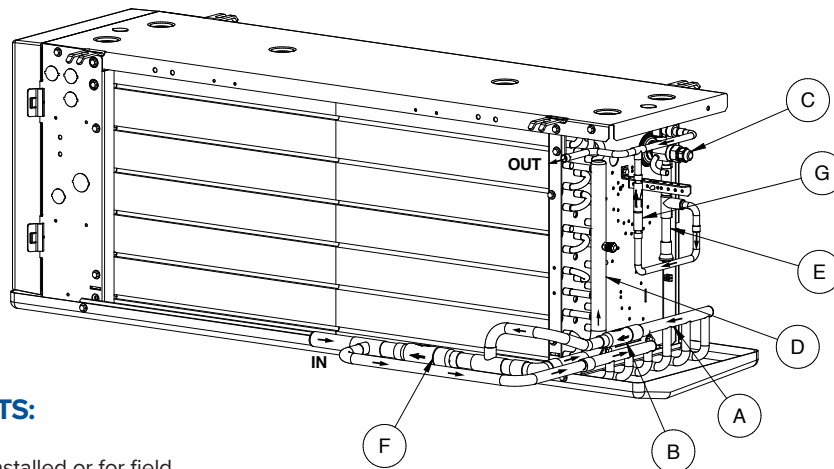
Reverse cycle defrost is a common method used in systems that include at least four unit coolers connected to a compressor rack. No more than 25% of the connected unit coolers are typically defrosted at the same time.

During reverse cycle, valving at the compressor rack diverts hot gas through the suction line to the defrosting unit cooler. See piping view in Figure 1. The suction line check valve directs the hot gas through the pan loop; heating the drain pan and preventing condensate from freezing during defrost. The hot gas exits the loop at the pan loop outlet header, passes through the drain pan check valve and enters the evaporator coil through the coil suction header. The hot refrigerant gas then flows through the defrosting coil, heating the finned surface and melting frost. As heat is transferred to the coil fins, hot refrigerant gas condenses to a liquid state. The refrigerant then exits the coil at the distributor side port, passes around the expansion valve through the bypass check valve and flows into the liquid refrigerant line. The liquid refrigerant then feeds other evaporators on the cooling cycle, evaporates, and returns to the compressor through their suction lines.

In some systems, electric drain pan heaters are used instead of a hot gas pan loop. Hot gas piping is simplified with the suction and drain pan check valves being eliminated. Electric drain pan heaters are energized during the defrost period, by a defrost control on the unit cooler or by a compressor rack controller.

REVERSE CYCLE DEFROST PIPING KEY COMPONENTS (FIG. 1)

- A. Hot gas drain pan loop
- B. Drain pan check valve
- C. Expansion valve
- D. Suction header
- E. Distributor
- F. Suction check valve
- G. Expansion valve bypass check valve



REVERSE CYCLE DEFROST PIPING KITS:

External check valve kit (available factory-installed or for field installation) includes suction check valve, drain pan check valve and piping to connect to suction header and hot gas drain pan loop. This kit is only necessary when the unit cooler is equipped with a hot gas drain pan loop.

Expansion valve bypass kit (available factory-installed or for field installation) includes expansion valve bypass check valve and piping to connect to the distributor side port and liquid line piping. The factory-installed version includes the expansion valve.

Use of external liquid/suction line heat exchanger with a reverse cycle system:

To increase the efficiency, higher performance and greater system protection, a heat exchanger may be beneficial to the system. In order to use a heat exchanger, the expansion valve bypass piping must be modified. See the piping view in Figure 2. The modification includes rerouting the pipe from the expansion valve bypass check valve to the inlet connection of the liquid line to the heat exchanger. A pipe needs to be routed from the liquid line outlet connection of the heat exchanger to the inlet connection of the thermostatic expansion valve.

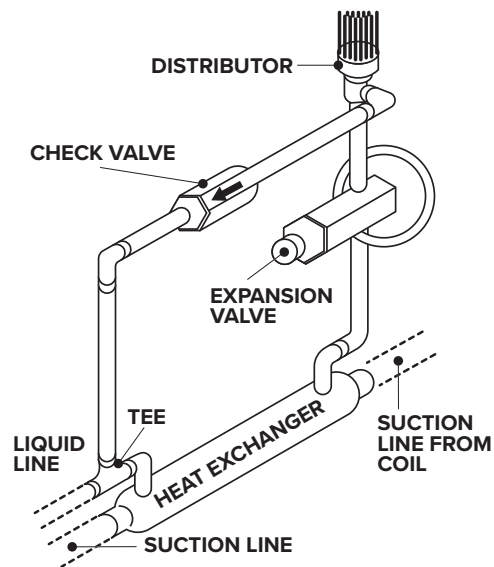


FIGURE 2. Typical Liquid Line Bypass Kit
(Shown assembled and modified for heat exchanger)

Three-pipe defrost unit cooler operation

Three-pipe defrost systems are connected to either a condensing unit or a compressor rack. No more than 33% of the connected unit coolers are typically defrosted at the same time.

During defrost, hot gas is directed through dedicated refrigerant piping (third pipe) to the defrosting unit cooler. See piping view in Figure 3. The hot gas enters the drain pan loop; heating the drain pan and preventing condensate from freezing during defrost. The hot gas exits the loop at the pan loop outlet header, passes through the drain pan check valve and enters the evaporator coil through the distributor side port connection. The hot refrigerant gas then flows through the defrosting coil, heating the finned surface and melting frost. As heat is transferred to the coil fins, hot refrigerant gas condenses to a liquid state. The refrigerant then exits the coil at the suction header.

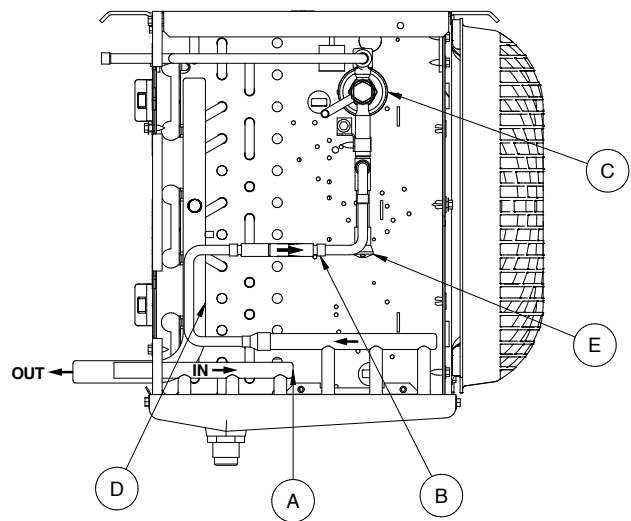
Three-pipe defrost unit cooler operation (cont.)

In some systems, electric drain pan heaters are used instead of a hot gas pan loop. Hot gas piping is simplified with the drain pan check valve being eliminated. Electric drain pan heaters are energized during the defrost period, by a defrost control on the unit cooler or by a compressor rack controller.

In order to provide sufficient re-evaporation of the liquid vapor mixture and sufficient heat for defrost, no more than one-third of the system should be defrosted at one time. Some means of control in the 3-pipe hot gas system should be supplied to regulate the large amount of liquid returning to the compressor, refrigerant slugging can otherwise damage the compressor.

REVERSE CYCLE THREE-PIPE DEFROST PIPING KEY COMPONENTS (FIG. 3)

- A. Hot gas drain pan loop
- B. Drain pan check valve
- C. Expansion valve
- D. Suction header
- E. Distributor



THREE-PIPE DEFROST PIPING KIT:

Three-pipe check valve kit (available factory-installed or for field installation) includes drain pan check valve and piping to connect the distributor side port to the hot gas drain pan loop. This kit is only necessary when the unit cooler is equipped with a hot gas drain pan loop.

Hot gas defrost controls:

Hot gas unit coolers are factory equipped with temperature control(s) that terminate the defrost cycle when the evaporator coil is clear of frost. After defrost, the control(s) keep the evaporator fans from re-energizing until the coil temperature is close to the freezing point.

STANDARD:

The standard control scheme includes an electromechanical defrost termination / fan delay control.

For reverse cycle defrost, the control sensing bulb is placed on the expansion valve bypass line, between the distributor side port and the expansion valve bypass check valve.

For three-pipe defrost, the control sensing bulb is placed on the suction header or suction header outlet connection.

OPTIONAL:

The optional control scheme includes an electromechanical defrost termination control and a separate bimetallic fan delay control. This scheme provides more options for the placement of the control sensing bulb as the defrost termination and fan delay sensing points are no longer combined.

The fan delay temperature is sensed on the evaporator coil endplate adjacent to the fins.

For reverse cycle defrost, the control sensing bulb is placed on the expansion valve bypass line or liquid line piping adjacent to the unit cooler.

For three-pipe defrost, the control sensing bulb is placed on the suction header or suction header outlet connection.

REPLACEMENT PARTS

Motor/Motor Mounts

Part #	Motor Type	Voltage	Motor Speeds	Motor Mount
25312501S / 25329001S	EC	115	1-SP / 2-SP	23108401*
25312601S / 25329101S	EC	208-230	2-SP	23108401*
25317701S	EC	208-230	1-SP	23108401
25309501S	PSC	115	1-SP	23108401
25309801S	PSC	208-230	1-SP	23108401
25309701S	PSC	460	1-SP	23106401

* = Consult factory when replacing motor mounts for motors 25329001S / 23529101S

Fan Blade

Part #	Description
5140C	Fan Blade 12" Std
5110E	Fan Blade 12" Reverse Air Flow

Fan Guard

Part #	Description
37001601	Fan Guard Wire Blue
37001801	Fan Guard Molded Blue

Cabinet Components

Part #	No. of Fans	Description	Defrost Type	Cabinet Aluminum	Application Notes
40594101	1	Drain Pan	Air/Hot Gas	Aluminum	Air, Hot Gas Models w/Drain Pan Loop
40595101	1	Drain Pan	Air/Hot Gas	White Painted Aluminum	Air, Hot Gas Models w/Drain Pan Loop
40596101	1	Drain Pan	Air/Hot Gas	Stainless Steel	Air Defrost Only
40594201	2	Drain Pan	Air/Hot Gas	Aluminum	Air, Hot Gas Models w/Drain Pan Loop
40595201	2	Drain Pan	Air/Hot Gas	White Painted Aluminum	Air, Hot Gas Models w/Drain Pan Loop
40596201	2	Drain Pan	Air/Hot Gas	Stainless Steel	Air Defrost Only
40594301	3	Drain Pan	Air/Hot Gas	Aluminum	Air, Hot Gas Models w/Drain Pan Loop
40595301	4	Drain Pan	Air/Hot Gas	White Painted Aluminum	Air, Hot Gas Models w/Drain Pan Loop
40596301	4	Drain Pan	Air/Hot Gas	Stainless Steel	Air Defrost Only
40594401	4	Drain Pan	Air/Hot Gas	Aluminum	Air, Hot Gas Models w/Drain Pan Loop
40595401	4	Drain Pan	Air/Hot Gas	White Painted Aluminum	Air, Hot Gas Models w/Drain Pan Loop
40596401	4	Drain Pan	Air/Hot Gas	Stainless Steel	Air Defrost Only
40594501	5	Drain Pan	Air/Hot Gas	Aluminum	Air, Hot Gas Models w/Drain Pan Loop
40595501	5	Drain Pan	Air/Hot Gas	White Painted Aluminum	Air, Hot Gas Models w/Drain Pan Loop
40596501	5	Drain Pan	Air/Hot Gas	Stainless Steel	Air Defrost Only
40594601	6	Drain Pan	Air/Hot Gas	Aluminum	Air, Hot Gas Models w/Drain Pan Loop
40595601	6	Drain Pan	Air/Hot Gas	White Painted Aluminum	Air, Hot Gas Models w/Drain Pan Loop
40596601	6	Drain Pan	Air/Hot Gas	Stainless Steel	Air Defrost Only

REPLACEMENT PARTS

Cabinet Components (cont.)

Part #	No. of Fans	Description	Defrost Type	Cabinet Aluminum	Application Notes
40594102	1	Drain Pan	Electric/Hot Gas	Aluminum	Elec, Hot Gas Models w/Drain Pan Heater
40595102	1	Drain Pan	Electric/Hot Gas	White Painted Aluminum	Elec, Hot Gas Models w/Drain Pan Heater
40594202	2	Drain Pan	Electric/Hot Gas	Aluminum	Elec, Hot Gas Models w/Drain Pan Heater
40595202	2	Drain Pan	Electric/Hot Gas	White Painted Aluminum	Elec, Hot Gas Models w/Drain Pan Heater
40594302	3	Drain Pan	Electric/Hot Gas	Aluminum	Elec, Hot Gas Models w/Drain Pan Heater
40595302	3	Drain Pan	Electric/Hot Gas	White Painted Aluminum	Elec, Hot Gas Models w/Drain Pan Heater
40594402	4	Drain Pan	Electric/Hot Gas	Aluminum	Elec, Hot Gas Models w/Drain Pan Heater
40595402	4	Drain Pan	Electric/Hot Gas	White Painted Aluminum	Elec, Hot Gas Models w/Drain Pan Heater
40594502	5	Drain Pan	Electric/Hot Gas	Aluminum	Elec, Hot Gas Models w/Drain Pan Heater
40595502	5	Drain Pan	Electric/Hot Gas	White Painted Aluminum	Elec, Hot Gas Models w/Drain Pan Heater
40594602	6	Drain Pan	Electric/Hot Gas	Aluminum	Elec, Hot Gas Models w/Drain Pan Heater
40595602	6	Drain Pan	Electric/Hot Gas	White Painted Aluminum	Elec, Hot Gas Models w/Drain Pan Heater
40593703	1	Insulated Outer Drain Pan Assy	All	Aluminum	Includes Outer Cover and Insulation
40593704	1	Insulated Outer Drain Pan Assy	All	White Painted Aluminum	Includes Outer Cover and Insulation
40593002	1	Insulated Outer Drain Pan Assy	All	Stainless Steel	Includes Outer Cover and Insulation
40593803	2	Insulated Outer Drain Pan Assy	All	Aluminum	Includes Outer Cover and Insulation
40593804	2	Insulated Outer Drain Pan Assy	All	White Painted Aluminum	Includes Outer Cover and Insulation
40593102	2	Insulated Outer Drain Pan Assy	All	Stainless Steel	Includes Outer Cover and Insulation
40591503	3	Insulated Outer Drain Pan Assy	All	Aluminum	Includes Outer Cover and Insulation
40591504	3	Insulated Outer Drain Pan Assy	All	White Painted Aluminum	Includes Outer Cover and Insulation
40593202	3	Insulated Outer Drain Pan Assy	All	Stainless Steel	Includes Outer Cover and Insulation
40591603	4	Insulated Outer Drain Pan Assy	All	Aluminum	Includes Outer Cover and Insulation
40591604	4	Insulated Outer Drain Pan Assy	All	White Painted Aluminum	Includes Outer Cover and Insulation
40593302	4	Insulated Outer Drain Pan Assy	All	Stainless Steel	Includes Outer Cover and Insulation
40591703	5	Insulated Outer Drain Pan Assy	All	Aluminum	Includes Outer Cover and Insulation
40591704	5	Insulated Outer Drain Pan Assy	All	White Painted Aluminum	Includes Outer Cover and Insulation
40593402	5	Insulated Outer Drain Pan Assy	All	Stainless Steel	Includes Outer Cover and Insulation
40591803	6	Insulated Outer Drain Pan Assy	All	Aluminum	Includes Outer Cover and Insulation

REPLACEMENT PARTS

Cabinet Components (cont.)

Part #	No. of Fans	Description	Defrost Type	Cabinet Aluminum	Application Notes
40591804	6	Insulated Outer Drain Pan Assy	All	White Painted Aluminum	Includes Outer Cover and Insulation
40593502	6	Insulated Outer Drain Pan Assy	All	Stainless Steel	Includes Outer Cover and Insulation
41032901	All	Access Panel RH (Elect) End	All	Aluminum/Stainless Steel	All w/Unpainted Cabinet
41032902	All	Access Panel RH (Elect) End	All	White Painted Aluminum	All w/White Cabinet
41032801	All	Access Panel LH (Refrig) End	All	Aluminum/Stainless Steel	Standard w/Unpainted Cabinet
41032802	All	Access Panel LH (Refrig) End	All	White Painted Aluminum	Standard w/White Cabinet
41032803	All	Access Panel LH (Refrig) End	Air/Electric	Aluminum/Stainless Steel	IntelliGen/QRC/Beacon II w/Unpainted Cabinet
41032804	All	Access Panel LH (Refrig) End	Air/Electric	White Painted Aluminum	IntelliGen/QRC/Beacon II w/White Cabinet
41038401	All	Access Panel LH (Refrig) End	Air/Electric	Aluminum	Glycol/CO ₂ Overfeed Only
41038402	All	Access Panel LH (Refrig) End	Air/Electric	White Painted Aluminum	Glycol/CO ₂ Overfeed Only
41038501	All	Access Panel LH (Refrig) End	Air/Electric	Stainless Steel	Glycol/CO ₂ Overfeed Only
41038701	All	Access Panel RH (Elect) End	Air/Electric	Aluminum	Glycol/CO ₂
41038702	All	Access Panel RH (Elect) End	Air/Electric	White Painted Aluminum	Glycol/CO ₂
41038901	All	Access Panel RH (Elect) End	Air/Electric	Stainless Steel	Glycol/CO ₂

Drain Pan Heaters

Part #	No. of Fans	Voltage	Wattage	Defrost Type	Application Notes
24753101	1	115	150	Hot Gas	Hot Gas Models w/Drain Pan Heater
24753102	2	115	300	Hot Gas	Hot Gas Models w/Drain Pan Heater
24753103	3	115	450	Hot Gas	Hot Gas Models w/Drain Pan Heater
24753104	4	115	600	Hot Gas	Hot Gas Models w/Drain Pan Heater
24753105	5	115	750	Hot Gas	Hot Gas Models w/Drain Pan Heater
24753106	6	115	900	Hot Gas	Hot Gas Models w/Drain Pan Heater
24752501	1	230	150	Electric /Hot Gas	Elec, Hot Gas Models w/Drain Pan Heater
24752502	2	230	300	Electric /Hot Gas	Elec, Hot Gas Models w/Drain Pan Heater
24752503	3	230	450	Electric /Hot Gas	Elec, Hot Gas Models w/Drain Pan Heater
24752504	4	230	600	Electric /Hot Gas	Elec, Hot Gas Models w/Drain Pan Heater
24752505	5	230	750	Electric /Hot Gas	Elec, Hot Gas Models w/Drain Pan Heater
24752506	6	230	900	Electric /Hot Gas	Elec, Hot Gas Models w/Drain Pan Heater
24753201	1	460	150	Hot Gas	Hot Gas Models w/Drain Pan Heater
24753202	2	460	300	Hot Gas	Hot Gas Models w/Drain Pan Heater
24753203	3	460	450	Hot Gas	Hot Gas Models w/Drain Pan Heater
24753204	4	460	600	Hot Gas	Hot Gas Models w/Drain Pan Heater
24753205	5	460	750	Hot Gas	Hot Gas Models w/Drain Pan Heater
24753206	6	460	900	Hot Gas	Hot Gas Models w/Drain Pan Heater

REPLACEMENT PARTS

Coil Defrost Heaters

Part #	No. of Fans	Voltage	Wattage	Defrost Type
24752001	1	230	300	Electric
24752002	2	230	600	Electric
24752003	3	230	900	Electric
24752004	4	230	1,200	Electric
24752005	5	230	1,500	Electric
24752006	6	230	1,800	Electric
24754101*	1	230	150	Electric
24754102*	2	230	300	Electric
24754103*	3	230	450	Electric
24754104*	4	230	600	Electric
24754105*	5	230	750	Electric
24754106*	6	230	900	Electric

* = One used per 460V unit only, top coil heater position

Electrical Components

Part #	Description	Defrost Type	Application Notes
22597101	Terminal Board	Air	All
22597701	Terminal Board	Electric/Hot Gas	All
5709L	Defrost Termination/Fan Delay Thermostat	Electric	Fixed Bi-Metallic Control
5708L	Heater Limit Thermostat	Electric	Fixed Bi-Metallic Control
4267W	Defrost Termination/Fan Delay Thermostat	Electric/Hot Gas	Adjustable Control
28913901	Room Thermostat	Air/Electric	Room Thermostat Mech
28963201	Room Thermostat	Air/Electric	Room Thermostat Elec

Drain Fitting

Part #	Description	Application Notes
26925101	Drain Fitting Kit	All

STANDARD NOZZLE SELECTION

Air Defrost

Medium Temperature (25°F SST)								
Model	No. of Fans	Distributor Tube (in.)		No. of Circuits	Nozzle Selections			
		OD	Length		R-404A/R-507A	R-448A/R-449A	R-407A/R-407F	R-407C
LEL0045*S6A^A	1	3/16	15	1	-	-	-	-
LEL0055*S6A^A	1	3/16	15	2	L-1/3	L-1/2	L-1/3	L-1/3
LEL0060*S6A^A	1	3/16	15	2	L-1/2	L-3/4	L-1/2	L-1/2
LEL0095*S6A^A	2	3/16	15	2	L-1/2	L-3/4	L-1/2	L-1/2
LEL0105*S6A^A	2	3/16	15	3	L-3/4	L-1	L-3/4	L-3/4
LEL0115*S6A^A	2	3/16	15	4	L-1	L-1-1/2	L-1	L-1
LEL0125*S6A^A	2	3/16	15	4	L-1	L-1-1/2	L-1	L-1
LEL0155*S6A^A	3	3/16	15	4	L-1	L-1-1/2	L-1	L-1
LEL0190*S6A^A	3	3/16	15	6	L-1-1/2	L-2	L-1-1/2	L-1-1/2
LEL0250*S6A^A	4	3/16	15	6	L-1-1/2	L-2	L-1-1/2	L-1-1/2
LEL0295*S6A^A	5	3/16	15	6	L-2	L-2-1/2	L-1-1/2	L-1-1/2
LEL0350*S6A^A	6	3/16	15	7	L-2	L-3	L-2	L-2
LEL0380*S6A^A	6	3/16	15	8	L-2-1/2	L-3	L-2-1/2	L-2-1/2

Notes:

Nozzles sized for 90-100°F liquid temperature at expansion valve.
 Contact Application Engineering for guidance if:
 - Liquid temperature is not 90-100°F
 - Evaporator TD is not 10°-15°F (room temperature – saturated suction temperature)
 Caution: Refrigeration system will not perform properly without correct nozzle

STANDARD NOZZLE SELECTION

Electric Defrost

Low Temperature (-20°F SST)								
Model	No. of Fans	Distributor Tube (in.)		No. of Circuits	Nozzle Selections			
		OD	Length		R-404A/R-507A	R-448A/R-449A	R-407A/R-407F	R-407C
LEL0040*S6E^A	1	3/16	15	2	L-1/2	L-3/4	L-1/2	-
LEL0045*S6E^A	1	3/16	15	2	L-3/4	L-3/4	L-1/2	-
LEL0065*S6E^A	2	3/16	15	3	L-3/4	L-1	L-3/4	-
LEL0080*S6E^A	2	3/16	15	3	L-1	L-1-1/2	L-1	-
LEL0100*S6E^A	2	3/16	15	6	L-1-1/2	L-1-1/2	L-1	-
LEL0130*S6E^A	3	3/16	15	6	L-1-1/2	L-2	L-1-1/2	-
LEL0155*S6E^A	3	3/16	15	8	L-2	L-2-1/2	L-2	-
LEL0170*S6E^A	4	3/16	15	6	L-2	L-2-1/2	L-2	-
LEL0205*S6E^A	4	3/16	15	8	L-2-1/2	L-3	L-2	-
LEL0240*S6E^A	5	3/16	15	8	L-2-1/2	L-4	L-2-1/2	-
LEL0255*S6E^A	6	3/16	15	9	L-3	L-4	L-3	-
LEL0310*S6E^A	6	3/16	15	12	L-4	L-5	L-3	-
LEL0045*S4E^A	1	3/16	15	2	L-1/2	L-3/4	L-1/2	-
LEL0070*S4E^A	2	3/16	15	3	L-3/4	L-1	L-3/4	-
LEL0090*S4E^A	2	3/16	15	6	L-1	L-1-1/2	L-1	-
LEL0135*S4E^A	3	3/16	15	6	L-1-1/2	L-2	L-1-1/2	-
LEL0180*S4E^A	4	3/16	15	8	L-2	L-2-1/2	L-2	-
LEL0220*S4E^A	5	3/16	15	8	L-2	L-3	L-2	-
LEL0275*S4E^A	6	3/16	15	12	L-3	L-4	L-3	-

Medium Temperature (25°F SST)								
Model	No. of Fans	Distributor Tube (in.)		No. of Circuits	Nozzle Selections			
		OD	Length		R-404A/R-507A	R-448A/R-449A	R-407A/R-407F	R-407C
LEL0040*S6E^A	1	3/16	15	2	L-1/4	L-1/3	L-1/4	L-1/4
LEL0045*S6E^A	1	3/16	15	2	L-1/3	L-1/2	L-1/3	L-1/3
LEL0065*S6E^A	2	3/16	15	3	L-1/2	L-3/4	L-1/2	L-1/2
LEL0080*S6E^A	2	3/16	15	3	L-3/4	L-3/4	L-1/2	L-1/2
LEL0100*S6E^A	2	3/16	15	6	L-3/4	L-1	L-3/4	L-3/4
LEL0130*S6E^A	3	3/16	15	6	L-1	L-1-1/2	L-1	L-1
LEL0155*S6E^A	3	3/16	15	8	L-1	L-1-1/2	L-1	L-1
LEL0170*S6E^A	4	3/16	15	6	L-1-1/2	L-1-1/2	L-1-1/2	L-1-1/2
LEL0205*S6E^A	4	3/16	15	8	L-1-1/2	L-2	L-1-1/2	L-1-1/2
LEL0240*S6E^A	5	3/16	15	8	L-1-1/2	L-2	L-1-1/2	L-1-1/2
LEL0255*S6E^A	6	3/16	15	9	L-2	L-2-1/2	L-2	L-2
LEL0310*S6E^A	6	3/16	15	12	L-2	L-3	L-2	L-2
LEL0045*S4E^A	1	3/16	15	2	L-1/3	L-1/2	L-1/4	L-1/4
LEL0070*S4E^A	2	3/16	15	3	L-1/2	L-3/4	L-1/2	L-1/2
LEL0090*S4E^A	2	3/16	15	6	L-3/4	L-3/4	L-3/4	L-3/4
LEL0135*S4E^A	3	3/16	15	6	L-3/4	L-1	L-3/4	L-3/4
LEL0180*S4E^A	4	3/16	15	8	L-1	L-1-1/2	L-1	L-1
LEL0220*S4E^A	5	3/16	15	8	L-1-1/2	L-2	L-1-1/2	L-1-1/2
LEL0275*S4E^A	6	3/16	15	12	L-2	L-2-1/2	L-2	L-2

Notes:

Nozzles sized for 90-100°F liquid temperature at expansion valve.
 Contact Application Engineering for guidance if:
 - Liquid temperature is not 90-100°F
 - Evaporator TD is not 10°-15°F (room temperature – saturated suction temperature)
 Caution: Refrigeration system will not perform properly without correct nozzle

STANDARD NOZZLE SELECTION

Hot Gas Defrost

Low Temperature (-20°F SST)

Model	No. of Fans	Distributor Tube (in.)		No. of Circuits	Nozzle Selections			
		OD	Length		R-404A/R-507A	R-448A/R-449A	R-407A/R-407F	R-407C
LEL0040*S6H^A	1	3/16	15	2	L-1/2	L-3/4	L-1/2	-
LEL0045*S6H^A	1	3/16	15	2	L-3/4	L-3/4	L-1/2	-
LEL0065*S6H^A	2	3/16	15	3	L-3/4	L-1	L-3/4	-
LEL0080*S6H^A	2	3/16	15	3	L-1	L-1-1/2	L-1	-
LEL0100*S6H^A	2	3/16	15	6	L-1-1/2	L-1-1/2	L-1	-
LEL0130*S6H^A	3	3/16	15	6	L-1-1/2	L-2	L-1-1/2	-
LEL0155*S6H^A	3	3/16	15	8	L-2	L-2-1/2	L-2	-
LEL0170*S6H^A	4	3/16	15	6	L-2	L-2-1/2	L-2	-
LEL0205*S6H^A	4	3/16	15	8	L-2-1/2	L-3	L-2	-
LEL0240*S6H^A	5	3/16	15	8	L-2-1/2	L-4	L-2-1/2	-
LEL0255*S6H^A	6	3/16	15	9	L-3	L-4	L-3	-
LEL0310*S6H^A	6	3/16	15	12	L-4	L-5	L-3	-
LEL0045*S4H^A	1	3/16	15	2	L-1/2	L-3/4	L-1/2	-
LEL0070*S4H^A	2	3/16	15	3	L-3/4	L-1	L-3/4	-
LEL0090*S4H^A	2	3/16	15	6	L-1	L-1-1/2	L-1	-
LEL0135*S4H^A	3	3/16	15	6	L-1-1/2	L-2	L-1-1/2	-
LEL0180*S4H^A	4	3/16	15	8	L-2	L-2-1/2	L-2	-
LEL0220*S4H^A	5	3/16	15	8	L-2	L-3	L-2	-
LEL0275*S4H^A	6	3/16	15	12	L-3	L-4	L-3	-

Medium Temperature (25°F SST)

Model	No. of Fans	Distributor Tube (in.)		No. of Circuits	Nozzle Selections			
		OD	Length		R-404A/R-507A	R-448A/R-449A	R-407A/R-407F	R-407C
LEL0040*S6H^A	1	3/16	15	2	L-1/4	L-1/3	L-1/4	L-1/4
LEL0045*S6H^A	1	3/16	15	2	L-1/3	L-1/2	L-1/3	L-1/3
LEL0065*S6H^A	2	3/16	15	3	L-1/2	L-3/4	L-1/2	L-1/2
LEL0080*S6H^A	2	3/16	15	3	L-3/4	L-3/4	L-1/2	L-1/2
LEL0100*S6H^A	2	3/16	15	6	L-3/4	L-1	L-3/4	L-3/4
LEL0130*S6H^A	3	3/16	15	6	L-1	L-1-1/2	L-1	L-1
LEL0155*S6H^A	3	3/16	15	8	L-1	L-1-1/2	L-1	L-1
LEL0170*S6H^A	4	3/16	15	6	L-1-1/2	L-1-1/2	L-1-1/2	L-1-1/2
LEL0205*S6H^A	4	3/16	15	8	L-1-1/2	L-2	L-1-1/2	L-1-1/2
LEL0240*S6H^A	5	3/16	15	8	L-1-1/2	L-2	L-1-1/2	L-1-1/2
LEL0255*S6H^A	6	3/16	15	9	L-2	L-2-1/2	L-2	L-2
LEL0310*S6H^A	6	3/16	15	12	L-2	L-3	L-2	L-2
LEL0045*S4H^A	1	3/16	15	2	L-1/3	L-1/2	L-1/4	L-1/4
LEL0070*S4H^A	2	3/16	15	3	L-1/2	L-3/4	L-1/2	L-1/2
LEL0090*S4H^A	2	3/16	15	6	L-3/4	L-3/4	L-3/4	L-3/4
LEL0135*S4H^A	3	3/16	15	6	L-3/4	L-1	L-3/4	L-3/4
LEL0180*S4H^A	4	3/16	15	8	L-1	L-1-1/2	L-1	L-1
LEL0220*S4H^A	5	3/16	15	8	L-1-1/2	L-2	L-1-1/2	L-1-1/2
LEL0275*S4H^A	6	3/16	15	12	L-2	L-2-1/2	L-2	L-2

Notes:

Nozzles sized for 90-100°F liquid temperature at expansion valve.
 Contact Application Engineering for guidance if:
 - Liquid temperature is not 90-100°F
 - Evaporator TD is not 10°-15°F (room temperature – saturated suction temperature)
 Caution: Refrigeration system will not perform properly without correct nozzle



2175 West Park Place Blvd.

Stone Mountain, GA 30087

Phone: 800.537.7775 · Fax: 770.465.5900

heatcraftspd.com

Since product improvement is a continuing effort, we reserve the right to make changes in specifications without notice.

LK-LOP-0622 | Version 004

©2022 Heatcraft Refrigeration Products LLC