

BOHN

BN-CM | **JANUARY 2024**
Replaces July 2022

CENTER MOUNT EVAPORATOR

Technical Guide
Including models meeting DOE minimum AWEF



TABLE OF CONTENTS

- 3** Features & Benefits
- 4** Outstanding Features
- 5** Nomenclature
- 5** Preferred Option Packages
- 6** Air Defrost
 - 6** Performance Data
 - 6** Application Capacity: Air Defrost- 60 Hz
 - 7** Unit Specifications
- 8** Electric Defrost
 - 8** Performance Data
 - 8** Application Capacity: Low Temperature Electric Defrost- 60 Hz
 - 9** Application Capacity: Medium Temperature Electric Defrost- 60 Hz
 - 10** Unit Specifications
- 11** Physical Data
- 12** Dimensional Drawings
- 13** Dimensional Data
- 14** DOE Rated AWEF
 - 14** AWEF Data
 - 14** Air Defrost
 - 15** Electric Defrost
- 16** Replacement Parts
- 17** Standard Nozzle Selection
 - 17** Air Defrost
 - 17** Electric Defrost



FEATURES & BENEFITS

CABINET

- Air moves across the ceiling in both directions providing even air distribution throughout the cooler
- Compact, ceiling mount and center mount design allows for shelving and storage of product around all walls
- Heavy-gauge grained aluminum cabinet cleans easily and looks attractive
- Cabinet design features improved access panels on each end for easy access to electrical and refrigeration components
- Improved wire management and routing
- Quick disconnect, waterproof plug and receptacle for each motor in all models
- Molded fan guard is made of strong, durable, NSF and UL Sanitation rated lightweight and damage resistant plastic material
- Liquid line solenoid wire harness is factory-installed for quick installation

COIL

- High-efficiency aluminum fins with full collars cover mechanically expanded copper tubes
- Coils are dehydrated and sealed at the factory
- Electric defrost models incorporate high quality tubular heaters and a standard fixed defrost termination thermostat
- Generous coil surface gives proper compressor balance
- Standard adjustable defrost termination fan delay thermostat
- Internally enhanced tubing and fin design for higher efficiency
- Optimized heater placement with reduced heater wattages
- Fixed defrost termination for electric, adjustable defrost termination for hot gas

DRAIN PAN

- Hinged drain pan for faster, easier and safer access and serviceability
- Tapered mounting provides proper slope for condensate drainage to one end of the unit
- Double drain pan eliminates drain pan sweating

MOTOR

- Motor rail is design for maximum strength and durability
- Motors are life lubricated and thermal overload protected
- 2 Speed EC Motors are factory-installed

CONTROL OPTIONS

- intelliGen™ Refrigeration Controller (iRC) units come with a factory mounted controller, tested and calibrated with an electronic expansion valve, pressure transducer, temperature sensors, control board and user interface. Standard features include Door Sensor, Product Load Input and Alarm Output.
- Optional Factory or Field installable intelliGen Webserver Card (iWC) enables local and remote monitoring on any Phone, Tablet or PC.
- Optional Factory or Field installable intelliGen Integration Card (iIC) enables connectivity to BACnet and Modbus.

OTHER OPTIONS

- Factory installed mounted components are available in these configurations:
- Pre-assembled units available with mounted TXV, liquid line solenoid valve and room thermostat
- Mounted TXV
- Mounted TXV and solenoid valve
- Units available with stainless steel housing and drain pan
- Air defrost units are available with various coil coatings options

OUTSTANDING FEATURES



Improved **wire management** and routing

Easily removable end access panel with captive fasteners

2 Speed EC motor standard

Optional IntelliGen™ Refrigeration Controller

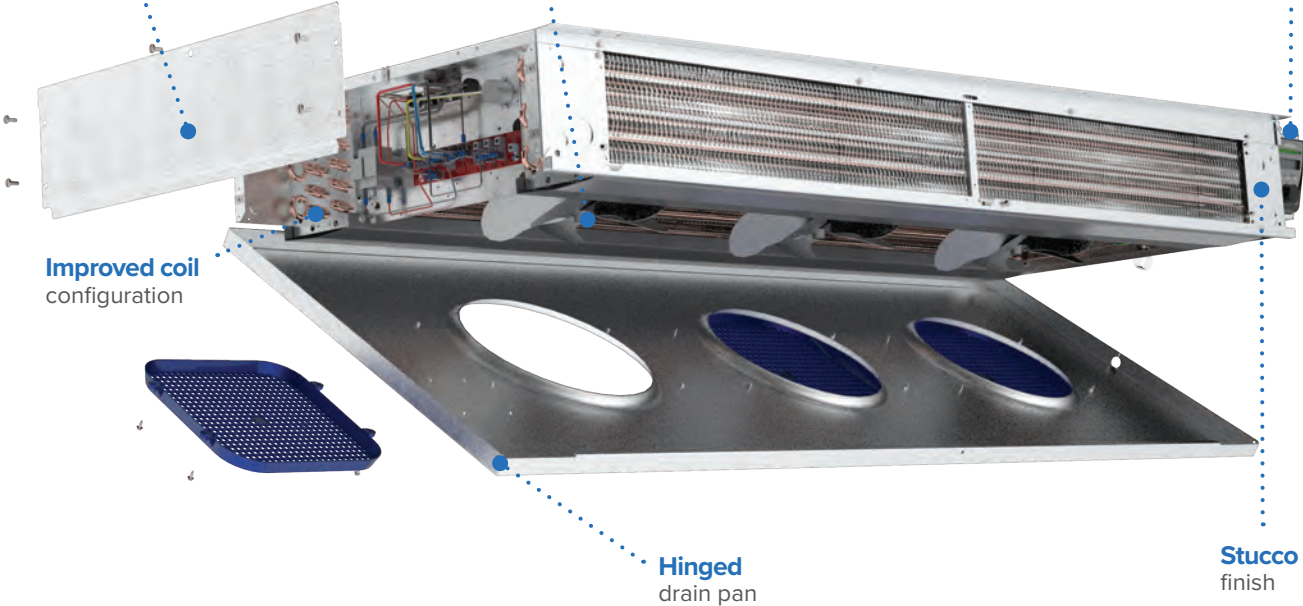

Improved coil configuration

Hinged drain pan

Stucco finish

Table 1: Capacity Correction Factors

Electric and Hot Gas Defrost Units				
Saturated Suction Temperature °F	+20	-10	-20	-30
Saturated Suction Temperature °C	-7	-23	-29	-34
Multiply Capacity By	1.15	1.04	1.00	0.90

NOMENCLATURE

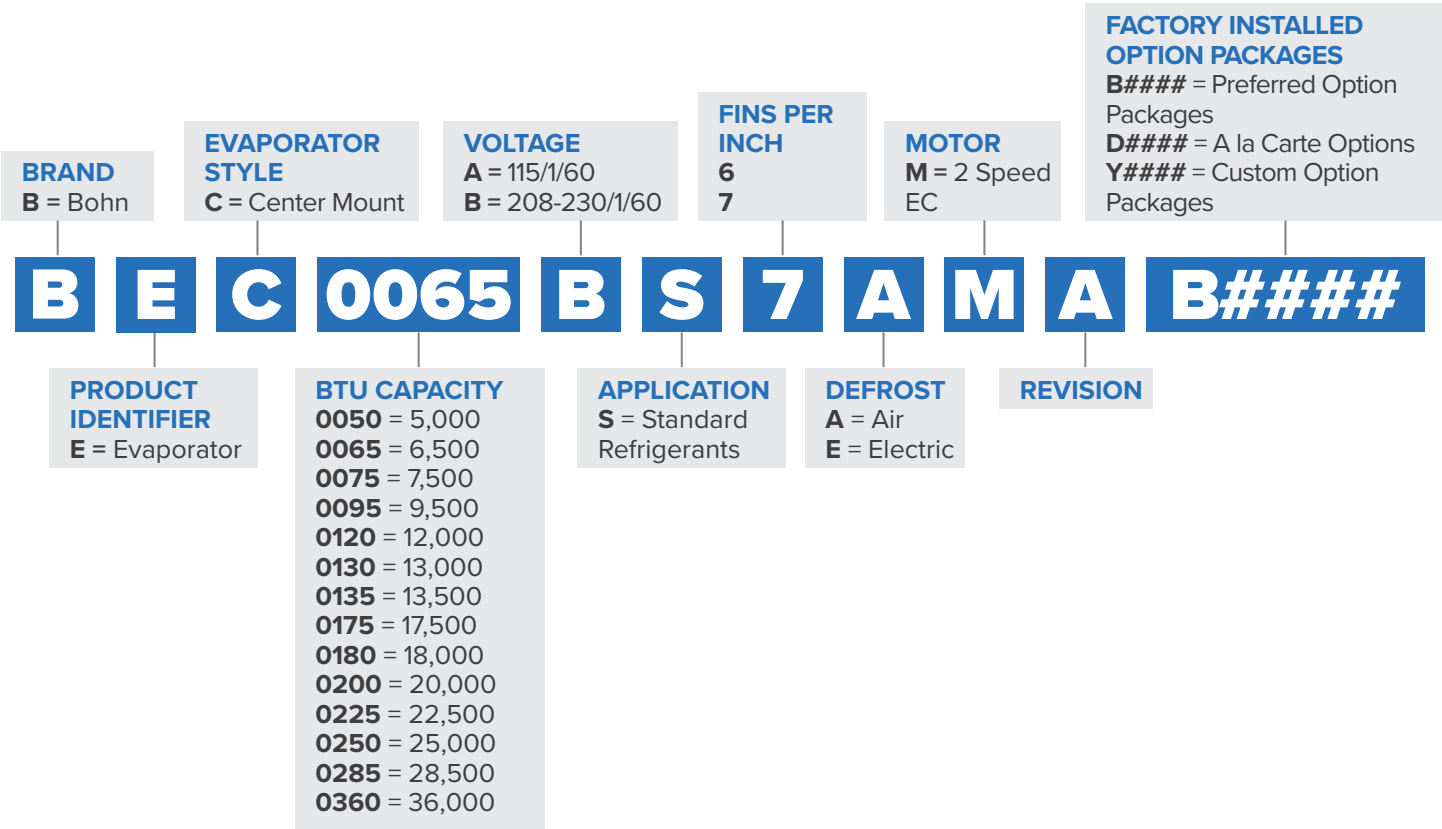

PREFERRED OPTION PACKAGES

Package	Description
B0200	intelliGen Refrigeration Controller (R-404A/R-448A/R-449A)
B0201	intelliGen Refrigeration Controller (R-407A/C/F)
B0403	Mounted Components (TXV, Solenoid Valve, Elec. T'stat - R-404A)
B0404	Mounted Components (TXV, Solenoid Valve, Elec. T'stat - R-407A/C/F)
B0405	Mounted Components (TXV, Solenoid Valve, Elec. T'stat - R-448A/R-449A)

PERFORMANCE DATA

Application Capacity: Air Defrost- 60 Hz

Please consult AWEF table on page 14 to confirm model meets DOE minimum AWEF

New Model	Legacy Model	R-404A/R-507A		R-448A/R-449A		Fan Data		
		Application Capacity ¹		Application Capacity ¹				
		10°F TD/25°F SST	6°C TD/4°C SST	10°F TD/25°F SST	6°C TD/4°C SST	No. of Fans	CFM	m ³ H
		BTUH	Watts	BTUH	Watts			
BEC0065*S7AMA	SM052	5,200	1,524	6,400	1,875	1	610	1,036
BEC0095*S7AMB	SM076 SM090	7,000	2,051	9,100	2,666	2	1,220	2,073
BEC0130*S7AMA	SM102	9,100	2,666	13,000	3,809	2	1,220	2,073
BEC0175*S7AMA	SM108	10,800	3,164	17,350	5,084	3	1,830	3,109
BEC0200*S7AMA	SM134	13,400	3,926	19,900	5,831	3	1,830	3,109
BEC0225*S7AMA	SM156	15,600	4,571	22,300	6,534	3	1,830	3,109
BEC0250*S7AMA	SM179	17,900	5,245	24,700	7,237	4	2,440	4,146
BEC0285*S7AMA	SM208	20,800	6,094	28,300	8,292	4	2,440	4,146
BEC0360*S7AMA	SM249	24,900	7,296	35,750	10,475	5	3,050	5,182

New Model	Legacy Model	R-407A/R-407F		R-407C		Fan Data		
		Application Capacity ¹		Application Capacity ¹				
		10°F TD/25°F SST	6°C TD/4°C SST	10°F TD/25°F SST	6°C TD/4°C SST	No. of Fans	CFM	m ³ H
		BTUH	Watts	BTUH	Watts			
BEC0065*S7AMA	SM052	6,400	1,875	6,400	1,875	1	610	1,036
BEC0095*S7AMB	SM076 SM090	9,100	2,666	9,100	2,666	2	1,220	2,073
BEC0130*S7AMA	SM102	13,000	3,809	13,000	3,809	2	1,220	2,073
BEC0175*S7AMA	SM108	17,350	5,084	17,350	5,084	3	1,830	3,109
BEC0200*S7AMA	SM134	19,900	5,831	19,900	5,831	3	1,830	3,109
BEC0225*S7AMA	SM156	22,300	6,534	22,300	6,534	3	1,830	3,109
BEC0250*S7AMA	SM179	24,700	7,237	24,700	7,237	4	2,440	4,146
BEC0285*S7AMA	SM208	28,300	8,292	28,300	8,292	4	2,440	4,146
BEC0360*S7AMA	SM249	35,750	10,475	35,750	10,475	5	3,050	5,182

Notes:
¹ = Capacities shown are Application Capacities reflecting nominal operation at 10°F TD. For models within the scope of the DOE AWEF (Annual Walk-in Energy Factor) standard, the Net Capacity is determined by the AHRI 1250 test method. DOE will publish this compliance data at www.regulations.doe.gov
 * = Electrical Code Designator (see Nomenclature details)
 Net Capacity is available upon request

SPECIFICATIONS

Air Defrost- 60 Hz

Please consult AWEF table on page 14 to confirm model meets DOE minimum AWEF

New Model	HP	2 Speed EC Motor							
		115/1/60				208-230/1/60			
		Amps	Watts	MCA	MOPD	Amps	Watts	MCA	MOPD
BEC0065*S7AMA	1/20	0.8	55	1.1	20	0.4	55	0.6	15
BEC0095*S7AMB	1/20	1.7	110	2.0	20	0.8	110	1.1	15
BEC0130*S7AMA	1/20	1.7	110	2.0	20	0.8	110	1.1	15
BEC0175*S7AMA	1/20	2.5	165	2.9	20	1.3	165	1.6	15
BEC0200*S7AMA	1/20	2.5	165	2.9	20	1.3	165	1.6	15
BEC0225*S7AMA	1/20	2.5	165	2.9	20	1.3	165	1.6	15
BEC0250*S7AMA	1/20	3.4	220	3.8	20	1.7	220	2.1	15
BEC0285*S7AMA	1/20	3.4	220	3.8	20	1.7	220	2.1	15
BEC0360*S7AMA	1/20	4.2	275	4.7	20	2.1	275	2.6	15

Notes:

* = Electrical Code Designator (see Nomenclature for details)

PERFORMANCE DATA

Application Capacity: Low Temperature Electric Defrost- 60 Hz

Please consult AWEF table on page 15 to confirm model meets model meets DOE minimum AWEF

Please refer to Table 1: Capacity Correction Factors (page 4) if using Saturated Suction Temperatures different than listed in the information below

New Model	Legacy Model	R-404A/R-507A		R-448A/R-449A		Fan Data		
		Application Capacity ¹		Application Capacity ¹				
		10°F TD/-20°F SST	6°C TD/-29°C SST	10°F TD/-20°F SST	6°C TD/-29°C SST	No. of Fans	CFM	m ³ H
		BTUH	Watts	BTUH	Watts			
BEC0050BS6EMA	SME040	4,000	1,172	5,500	1,612	1	610	1,036
BEC0075BS6EMA	SME054 SME065	6,500	1,905	8,700	2,549	2	1,220	2,073
BEC0120BS6EMA	SME090	9,000	2,637	13,600	3,985	3	1,830	3,109
BEC0135BS6EMA	SME130	13,000	3,809	15,700	4,600	3	1,830	3,109
BEC0180BS6EMA	SME174	17,400	5,098	21,100	6,182	4	2,440	4,146
BEC0255BS6EMA	N/A	18,000	5,274	25,500	7,472	5	3,050	5,182
BEC0280BS6EMA	N/A	19,000	5,567	28,000	8,204	5	3,050	5,182

New Model	Legacy Model	R-407A/R-407F		R-407C		Fan Data		
		Application Capacity ¹		Application Capacity ¹				
		10°F TD/-20°F SST	6°C TD/-29°C SST	10°F TD/-20°F SST	6°C TD/-29°C SST	No. of Fans	CFM	m ³ H
		BTUH	Watts	BTUH	Watts			
BEC0050BS6EMA	SME040	5,500	1,612	5,500	1,612	1	610	1,036
BEC0075BS6EMA	SME054 SME065	8,700	2,549	8,700	2,549	2	1,220	2,073
BEC0120BS6EMA	SME090	13,600	3,985	13,600	3,985	3	1,830	3,109
BEC0135BS6EMA	SME130	15,700	4,600	15,700	4,600	3	1,830	3,109
BEC0180BS6EMA	SME174	21,100	6,182	21,100	6,182	4	2,440	4,146
BEC0255BS6EMA	N/A	25,500	7,472	25,500	7,472	5	3,050	5,182
BEC0280BS6EMA	N/A	28,000	8,204	28,000	8,204	5	3,050	5,182

Notes:
¹ = Capacities shown are Application Capacities reflecting nominal operation at 10°F TD. For models within the scope of the DOE AWEF (Annual Walk-in Energy Factor) standard, the Net Capacity is determined by the AHRI 1250 test method. DOE will publish this compliance data at www.regulations.doe.gov
 Net Capacity is available upon request

PERFORMANCE DATA

Application Capacity: Medium Temperature Electric Defrost- 60 Hz

Please consult AWEF table on page 15 to confirm model meets DOE minimum AWEF

Please refer to Table 1: Capacity Correction Factors (page 4) if using Saturated Suction Temperatures different than listed in the information below

New Model	Legacy Model	R-404A/R-507A		R-448A/R-449A		Fan Data		
		Application Capacity ¹		Application Capacity ¹				
		10°F TD/25°F SST	6°C TD/4°C SST	10°F TD/25°F SST	6°C TD/4°C SST	No. of Fans	CFM	m ³ H
		BTUH	Watts	BTUH	Watts			
BEC0050BS6EMA	SME040	4,600	1,348	6,325	1,853	1	610	1,036
BEC0075BS6EMA	SME054 SME065	7,450	2,183	10,005	2,931	2	1,220	2,073
BEC0120BS6EMA	SME090	10,350	3,033	15,640	4,583	3	1,830	3,109
BEC0135BS6EMA	SME130	14,950	4,380	18,055	5,290	3	1,830	3,109
BEC0180BS6EMA	SME174	20,000	5,860	24,265	7,110	4	2,440	4,146
BEC0255BS6EMA	N/A	20,700	6,065	29,325	8,592	5	3,050	5,182
BEC0280BS6EMA	N/A	21,850	6,402	32,200	9,435	5	3,050	5,182

New Model	Legacy Model	R-407A/R-407F		R-407C		Fan Data		
		Application Capacity ¹		Application Capacity ¹				
		10°F TD/25°F SST	6°C TD/4°C SST	10°F TD/25°F SST	6°C TD/4°C SST	No. of Fans	CFM	m ³ H
		BTUH	Watts	BTUH	Watts			
BEC0050BS6EMA	SME040	6,325	1,853	6,325	1,853	1	610	1,036
BEC0075BS6EMA	SME054 SME065	10,005	2,931	10,005	2,931	2	1,220	2,073
BEC0120BS6EMA	SME090	15,640	4,583	15,640	4,583	3	1,830	3,109
BEC0135BS6EMA	SME130	18,055	5,290	18,055	5,290	3	1,830	3,109
BEC0180BS6EMA	SME174	24,265	7,110	24,265	7,110	4	2,440	4,146
BEC0255BS6EMA	N/A	29,325	8,592	29,325	8,592	5	3,050	5,182
BEC0280BS6EMA	N/A	32,200	9,435	32,200	9,435	5	3,050	5,182

Notes:

¹ = Capacities shown are Application Capacities reflecting nominal operation at 10°F TD. For models within the scope of the DOE AWEF (Annual Walk-in Energy Factor) standard, the Net Capacity is determined by the AHRI 1250 test method. DOE will publish this compliance data at www.regulations.doe.gov
Net Capacity is available upon request

SPECIFICATIONS

Electric Defrost- 60 Hz

Please consult AWEF table on page 15 to confirm model meets DOE minimum AWEF

Please refer to Table 1: Capacity Correction Factors (page 4) if using Saturated Suction Temperatures different than listed in the information below

New Model	HP	2 Speed EC Motor (Totally Enclosed)				Defrost Heaters	
		208-230/1/60					
		Amps	Watts	MCA	MOPD	Watts	Total Amps
BEC0050BS6EMA	1/20	0.4	55	0.6	15	1,200	5.3
BEC0075BS6EMA	1/20	0.8	110	1.1	15	2,000	8.7
BEC0120BS6EMA	1/20	1.3	165	1.6	15	2,400	10.5
BEC0135BS6EMA	1/20	1.3	165	1.6	15	3,600	15.7
BEC0180BS6EMA	1/20	1.7	220	2.1	15	4,800	20.9
BEC0255BS6EMA	1/20	2.1	275	2.6	15	6,000	26.1
BEC0280BS6EAM	1/20	2.1	275	2.6	15	6,000	26.1

PHYSICAL DATA

Air Defrost

Model	No. of Fans	Coil Inlet OD	Suction OD	Equalizer OD	Drain MPT	Approx. Net Weight	
						lb	kg
BEC0065*S7AMA	1	1/2	1 - 1/8	1/4	3/4	50	23
BEC0095*S7AMB	2	1/2	1 - 1/8	1/4	3/4	100	45
BEC0130*S7AMA	2	1/2	1 - 1/8	1/4	3/4	100	45
BEC0175*S7AMA	3	1/2	1 - 1/8	1/4	3/4	126	57
BEC0200*S7AMA	3	1/2	1 - 1/8	1/4	3/4	141	64
BEC0225*S7AMA	3	1/2	1 - 1/8	1/4	3/4	148	67
BEC0250*S7AMA	4	1/2	1 - 1/8	1/4	3/4	179	81
BEC0285*S7AMA	4	1/2	1 - 1/8	1/4	3/4	197	89
BEC0360*S7AMA	5	1/2	1 - 1/8	1/4	3/4	248	112

Electric Defrost

Model	No. of Fans	Coil Inlet OD	Suction OD	Equalizer OD	Drain MPT	Approx. Net Weight	
						lb	kg
BEC0050BS6EMA	1	1/2	1 - 1/8	1/4	3/4	108	49
BEC0075BS6EMA	2	1/2	1 - 1/8	1/4	3/4	144	65
BEC0120BS6EMA	3	1/2	1 - 1/8	1/4	3/4	192	87
BEC0135BS6EMA	3	1/2	1 - 1/8	1/4	3/4	209	95
BEC0180BS6EMA	4	1/2	1 - 1/8	1/4	3/4	262	119
BEC0255BS6EMA	5	1/2	1 - 1/8	1/4	3/4	290	132
BEC0280BS6EMA	5	1/2	1 - 1/8	1/4	3/4	290	132

Notes:

* = Electrical Code Designator (see Nomenclature details)

All connections are in “

DIMENSIONAL DRAWINGS

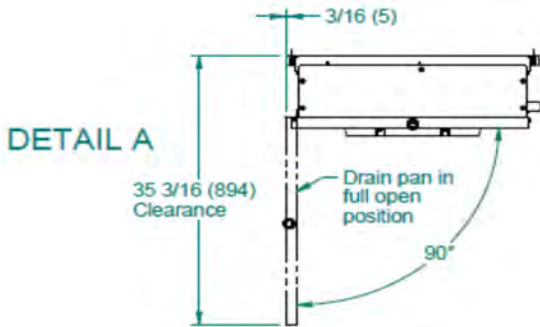
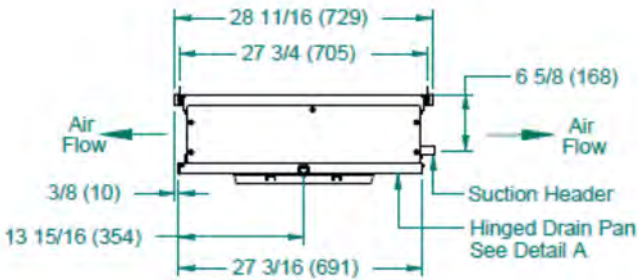
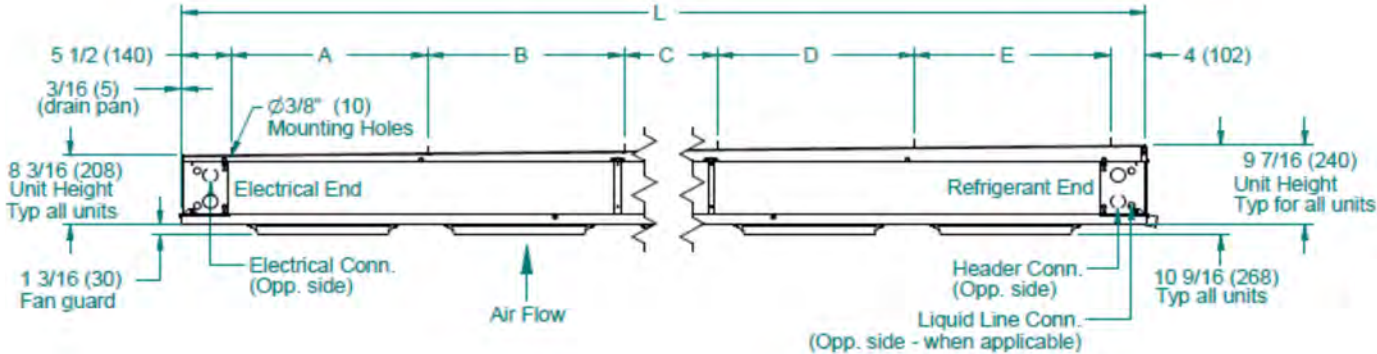

DIMENSIONAL DATA

Dimensional Data For Air Defrost

Model	No. of Fans	L	A	B	C	D	E
		Inches (mm)	Inches (mm)	Inches (mm)	Inches (mm)	Inches (mm)	Inches (mm)
BEC0065*S7AMA	1	31 1/2 (800)	22 (559)	-	-	-	-
BEC0095*S7AMB	2	53 1/2 (1359)	22 (559)	22 (559)	-	-	-
BEC0130*S7AMA	2	53 1/2 (1359)	22 (559)	22 (559)	-	-	-
BEC0175*S7AMA	3	75 1/2 (1918)	22 (559)	22 (559)	22 (559)	-	-
BEC0200*S7AMA	3	75 1/2 (1918)	22 (559)	22 (559)	22 (559)	-	-
BEC0225*S7AMA	3	75 1/2 (1918)	22 (559)	22 (559)	22 (559)	-	-
BEC0250*S7AMA	4	97 1/2 (2477)	22 (559)	22 (559)	22 (559)	22 (559)	-
BEC0285*S7AMA	4	97 1/2 (2477)	22 (559)	22 (559)	22 (559)	22 (559)	-
BEC0360*S7AMA	5	119 1/2 (3035)	22 (559)	22 (559)	22 (559)	22 (559)	22 (559)

Dimensional Data For Electric Defrost

Model	No. of Fans	L	A	B	C	D	E
		Inches (mm)	Inches (mm)	Inches (mm)	Inches (mm)	Inches (mm)	Inches (mm)
BEC0050BS6EMA	1	31 1/2 (800)	22 (559)	-	-	-	-
BEC0075BS6EMA	2	53 1/2 (1359)	22 (559)	22 (559)	-	-	-
BEC0120BS6EMA	3	75 1/2 (1918)	22 (559)	22 (559)	22 (559)	-	-
BEC0135BS6EMA	3	75 1/2 (1918)	22 (559)	22 (559)	22 (559)	-	-
BEC0180BS6EMA	4	97 1/2 (1918)	22 (559)	22 (559)	22 (559)	22 (559)	-
BEC0255BS6EMA	5	119 1/2 (3035)	22 (559)	22 (559)	22 (559)	22 (559)	22 (559)
BEC0280BS6EMA	5	119 1/2 (3035)	22 (559)	22 (559)	22 (559)	22 (559)	22 (559)

Notes:

* = Electrical Code Designator (see Nomenclature details)

DOE Rated AWEF

AWEF DATA

Air Defrost

FPI	Model	Cooler			
		R-404A/ R-507A	R-448A/ R-449A	R-407A/ R-407F	R-407C
		AWEF	AWEF	AWEF	AWEF
7	BEC0065*S7AMA	9.0	9.0	9.0	9.0
7	BEC0095*S7AMB	9.0	9.0	9.0	9.0
7	BEC0130*S7AMA	9.0	9.0	9.0	9.0
7	BEC0175*S7AMA	9.0	9.0	9.0	9.0
7	BEC0200*S7AMA	9.0	9.0	9.0	9.0
7	BEC0225*S7AMA	9.0	9.0	9.0	9.0
7	BEC0250*S7AMA	9.0	9.0	9.0	9.0
7	BEC0285*S7AMA	9.0	9.0	9.0	9.0
7	BEC0360*S7AMA	9.0	9.0	9.0	9.0

Notes:
 * = Electrical Code Designator (see Nomenclature details)

DOE Rated AWEF

AWEF DATA

Electric Defrost

FPI	Model	Freezer			
		R-404A/ R-507A	R-448A/ R-449A	R-407A/ R-407F	R-407C
		AWEF	AWEF	AWEF	AWEF
6	BEC0050BS6EMA	3.96	3.99	3.99	3.98
6	BEC0075BS6EMA	4.00	4.04	4.04	4.02
6	BEC0120BS6EMA	4.05	4.12	4.11	4.09
6	BEC0135BS6EMA	4.07	4.15	4.14	4.12
6	BEC0180BS6EMA	4.12	4.15	4.15	4.15
6	BEC0255BS6EMA	4.15	4.15	4.15	4.15
6	BEC0280BS6EMA	4.15	4.15	4.15	4.15

FPI	Model	Cooler			
		R-404A/ R-507A	R-448A/ R-449A	R-407A/ R-407F	R-407C
		AWEF	AWEF	AWEF	AWEF
6	BEC0050BS6EMA	-	9.0	9.0	9.0
6	BEC0075BS6EMA	-	9.0	9.0	9.0
6	BEC0120BS6EMA	9.0	9.0	9.0	9.0
6	BEC0135BS6EMA	9.0	9.0	9.0	9.0
6	BEC0180BS6EMA	9.0	9.0	9.0	9.0
6	BEC0255BS6EMA	9.0	9.0	9.0	9.0
6	BEC0280BS6EMA	9.0	9.0	9.0	9.0

REPLACEMENT PARTS

Cabinet Components

Part #	Description	No. of Fans
40420101	Drain Pan - Stucco	1
40420201	Drain Pan - Stucco	2
40420301	Drain Pan - Stucco	3
40420401	Drain Pan - Stucco	4
40420501	Drain Pan - Stucco	5

Electrical Components

Part #	Description
22597101	Terminal Board - Air Defrost
22597701	Terminal Board - Electric Defrost
22598201	2SP RELAY 24V
22598202	2SP RELAY 120V
22598203	2SP RELAY 240V
4267W	Defrost Termination / Fan Delay Thermostat

Motor/Fan Blade/Fan Guards

Part #	Description
25329001S	Motor 115/1/60 - 2 Speed EC
25329101S	Motor 208-230/1/60 - 2 Speed EC
5110E	Fan Blade
23106201	Fan Guard - Plastic
5055F	Fan Guard - Metal
41417501	Motor Mount Plate

Electric Components

Part #	Description	No. of Fans
4400S	Coil Heater	1
4401S	Coil Heater	2
4402S	Coil Heater - 4 Row Coil	3
4403S	Coil Heater - 5 Row Coil	3
4404S	Coil Heater	4
4405S	Coil Heater	5

STANDARD NOZZLE SELECTION

Air Defrost

Medium Temperature (25°F SST)								
Model	No. of Fans	Distributor Tube (in.)		No. of Circuits	Nozzle Selections			
		OD	Length		R-404A/R-507A	R-448A/R-449A	R-407A/R-407F	R-407C
BEC0065*S7AMA	1	3/16	18	4	L - 1/3	L - 1/2	L - 1/3	L - 1/3
BEC0095*S7AMB	2	3/16	18	4	L - 1/2	L - 3/4	L - 1/2	L - 1/2
BEC0130*S7AMA	2	3/16	18	4	L - 3/4	L - 1	L - 3/4	L - 3/4
BEC0175*S7AMA	3	3/16	18	4	L - 3/4	L - 1 1/2	L - 1	L - 1
BEC0200*S7AMA	3	3/16	18	6	L - 1	L - 1 1/2	L - 1	L - 1
BEC0225*S7AMA	3	3/16	24	8	L - 1	L - 2	L - 1 1/2	L - 1 1/2
BEC0250*S7AMA	4	3/16	18	6	L - 1 1/2	L - 2	L - 1 1/2	L - 1 1/2
BEC0285*S7AMA	4	3/16	24	8	L - 1 1/2	L - 2 1/2	L - 1 1/2	L - 1 1/2
BEC0360*S7AMA	5	3/16	18	10	L - 2	L - 3	L - 2	L - 2

Electric Defrost

Low Temperature (-20°F SST)								
Model	No. of Fans	Distributor Tube (in.)		No. of Circuits	Nozzle Selections			
		OD	Length		R-404A/R-507A	R-448A/R-449A	R-407A/R-407F	R-407C
BEC0050BS6EMA	1	3/16	18	4	L - 1/2	L - 1	L - 3/4	L - 1/2
BEC0075BS6EMA	2	3/16	18	4	L - 3/4	L - 1 1/2	L - 1	L - 1
BEC0120BS6EMA	3	3/16	18	6	L - 1 1/2	L - 2	L - 1 1/2	L - 1 1/2
BEC0135BS6EMA	3	3/16	24	8	L - 2	L - 2 1/2	L - 1 1/2	L - 1 1/2
BEC0180BS6EMA	4	3/16	18	10	L - 2	L - 4	L - 2 1/2	L - 2
BEC0255BS6EMA	5	3/16	18	10	L - 2 1/2	L - 4	L - 3	L - 3
BEC0280BS6EMA	5	3/16	18	10	L - 2 1/2	L - 4	L - 3	L - 3

Notes:

* = Electrical Code Designator (see Nomenclature details)



2175 West Park Place Blvd.

Stone Mountain, GA 30087

Phone: 800.537.7775 · Fax: 770.465.5900

heatcraftprd.com

Since product improvement is a continuing effort, we reserve the right to make changes in specifications without notice.

BN-CM-0124 | Version 006

©2024 Heatcraft Refrigeration Products LLC